

The Monthly Magazine  
for All Model  
Radio Control  
Car Enthusiasts

# Radio Race Car

October 1987 • Price £1.35 (UK) • \$3.00 (USA)

ALWAYS THE BEST ...  
AND NOW

## THE BIGGEST!

THE LID'S OFF  
THE  
LUNCH  
BOX

16 more  
pages  
every  
month

Tamiya's  
new 1/10th  
Custom  
Buggy



### WORLD CHAMPIONSHIP SPECIAL

1/8th Track  
from  
California

1/10th  
Off Road  
from  
Romsey



THERE ARE NOW 3 MORE GOOD REASONS TO CHOOSE

# KYOSHO

THE FINEST RADIO CONTROL MODELS



AT THE 1987 IFMAR  
**WORLD CHAMPS**

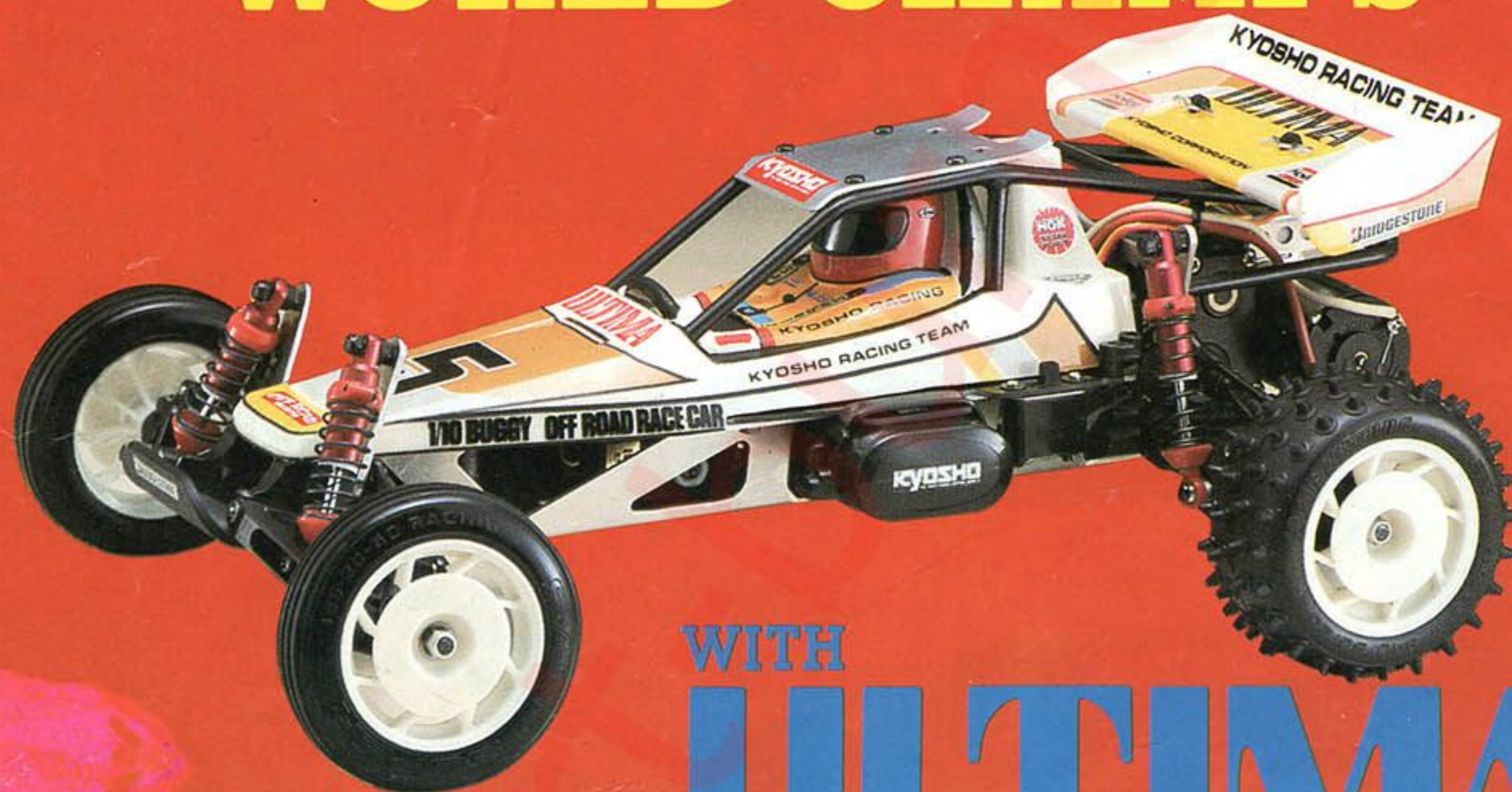

WITH  
**ULTIMA**  
THE ULTIMATE 2 WHEEL DRIVE

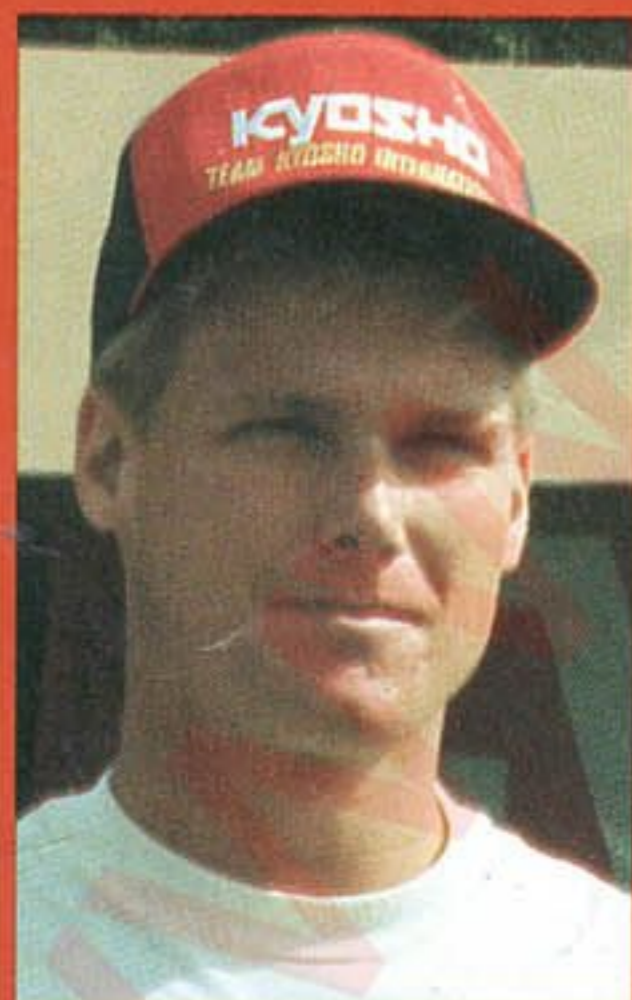

1st JOEL JOHNSON  
U.S.A.



2nd KATSUNORI KONDO  
JAPAN

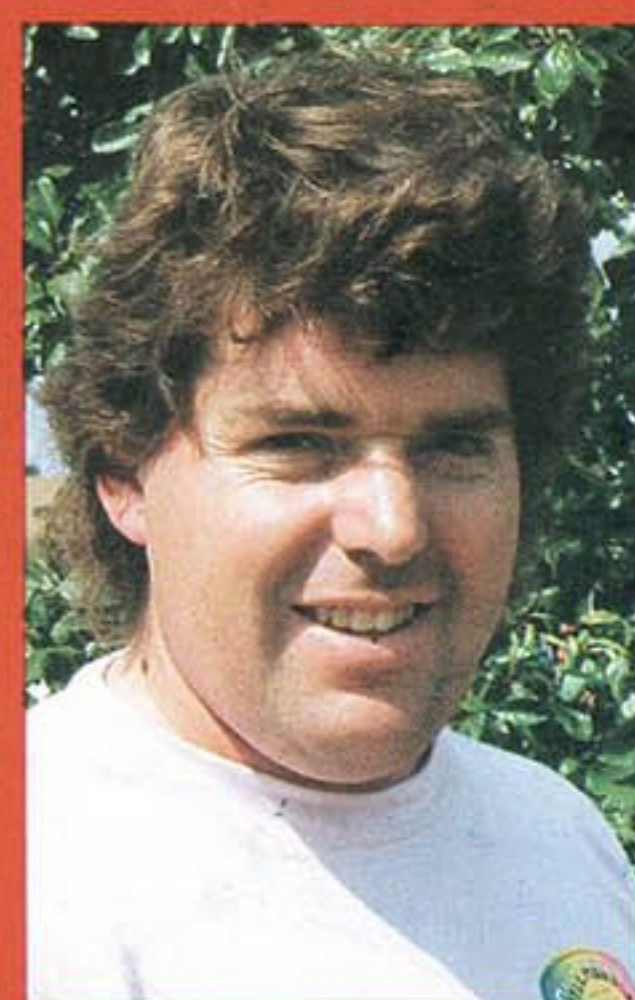

3rd KRIS MOORE  
U.S.A.

# Radio Race Car

## C O N T E N T S

October 1987 • Issue 47 • ISSN 0268-3334

MANAGING EDITOR  
**Tony Stephenson**

ADVERTISING MANAGER  
**Jane Stephenson**

EDITOR  
**Dave Pearson**

DESIGN MANAGER  
**Neil Blowers**

ASSOCIATE EDITOR  
**Gordon Batt**

ART PRODUCTION TEAM

**Bob Lambert • Sharon Billington • Simon Bates**

SPECIAL CONTRIBUTORS

**Mike Smith • Mr Rumbings • John Varley • Chris Evans • John Chamberlain • Nick Marson  
Jim Davey • Bob Errington • Mike Billinton**

### EDITORIAL

*A new broom sweeps clean, or so they say, well about the only sweeping change this month is in the magazine, sixteen extra pages of reviews, news, race reports and ideas from the world of radio controlled cars.*

*During the World Champs IFMAR, the governing body for this and other related World events, held a meeting in which several items were discussed, most were mundane, minor changes in policy, but convention demanded a full committee meeting for these to take place. However, two items that were worthy of note are as follows: Front, 2WD cars are now only allowed to race in World Championship events in the 4WD class. Is that fair? Secondly and with more consequence to us here in the UK, it seems that EFRA are the only section of the IFMAR threesome that do not wish to see 1/10 World Championship racing go to seven cells and four minutes, but a decision concerning this will be made in the next 12 months.*

*What does this mean to you the racer, well obviously if seven cell, four minute World Championships are accepted then we would certainly have to look at at least one series using this formulae so that the eligible racers can be selected. This then poses some problems in as much as new equipment will have to be purchased by a fairly large number of people, there are even some cars where seven cells just won't fit.*

*The pro's seem to be that the difference in battery capacity, which can vary by as much as 30% will be eliminated as no one could possibly use all that power in four minutes. Therefore negating the need to spend £35.00 plus on a selected battery pack. Any comments? If so why not write and tell us!*

*Finally a sour note, over the World Championship week at Romsey SRM's track shop was broken into and items stolen were as follows: a Futaba 3EGX complete combo, three Novak speed controllers, two Laser speed controllers and a LWB CAT, do you know anyone who has suddenly started using equipment such as this, especially since their return from the World Champs at Romsey? If you do we are certain that a phone call to Mick Longridge on 0329 234262 could be most rewarding!*

- 10 **Hands across the water. Stop press news from Traplet Publications Ltd.**
- 20 **Track Talk. Chris Evans reports from the world of 1/12 racing**
- 28 **Stock 'n' Oval. Mike Smith's report from the oval tracks**
- 34 **1/10 World Championships, RRC reports from Romsey**
- 46 **1/8 World Championships. A report from the Pamona raceway on the 1/8 circuit World Champs**
- 50 **Vanessa's Lunch Box. A new 1/12 scale car crusher from Tamiya**
- 53 **Pit Patter. Bob Errington gets wet and remembers the good old summer days at Tibshelf**
- 61 **Hover Bug. A new way of using 6 cells and a 540 motor**
- 68 **Cybon 1. A child's toy that has just that little bit extra**
- 70 **Market Place. What's new in the shops**
- 74 **An airy look at motor sprays. Do we really know what we are using?**
- 80 **Shoppers Directory**
- 82 **Classified Advertisements**

### Front Cover:

Tamiya's latest 1/12th Car Crusher, Vanessa's Lunch Box. (Inset) The World beating CAT, Romsey Victor.

All correspondence should be sent to Radio Race Car Magazine, Masefield House, Wells Road, Malvern, Worcestershire, WR14 4PA, England.

Tel: (06845) 60561/2/3. Telex: 334708 RCMAGS.

Radio Race Car Magazine is published monthly by Traplet Limited, Masefield House, Wells Road, Malvern, Worcestershire WR14 4PA, England.

Printed by Worcestershire Web Offset Limited, Droitwich, Worcester

Distributed to the Newsagency Trade by Magnum Distribution Ltd, Cloister Court, 22-26 Farringdon Lane, London EC1R 3AU. Tel. 01-253 3135

Distributed to North America hobby and craft stores, museums and bookshops by:

**Traplet Distribution USA Ltd., 1635 Wade Drive, Paso Robles, CA93446, USA. Tel. (805) 239 0997**

and by Bill Dean Books Ltd, 151-49 Seventh Avenue, Whitestone, New York, 11357, USA. Tel: 1-718-767-6632.

Annual Subscriptions are available at £18.00 UK, £22.00 (Sterling) Europe, £31.00 (Sterling) Worldwide (airmail). Send cheque/PO etc. to Radio Race Car (Subs Dept.), Masefield House, Wells Road, Malvern, Worcestershire WR14 4PA, England.

This magazine is sold subject to the following conditions; that it shall not without written consent of the publishers be lent, resold or otherwise disposed of by way of trade in excess of the recommended maximum retail price. All rights strictly reserved. No part of this publication may be reproduced in any way without the prior consent of the publisher.

All letters must be accompanied by the senders full name and address. The publisher cannot accept responsibility for unsolicited correspondence nor some of the opinions expressed. All articles and photographs used in this magazine become the publisher's copyright.

The Company reserves the right to suspend or refuse any advertisements without giving reasons. Whilst every care is taken to avoid mistakes Traplet Publications Ltd. cannot be liable in any way for any errors or omissions. Nor can the Publishers accept any responsibility for the bona fides of advertisers.

# MUSTANG X3

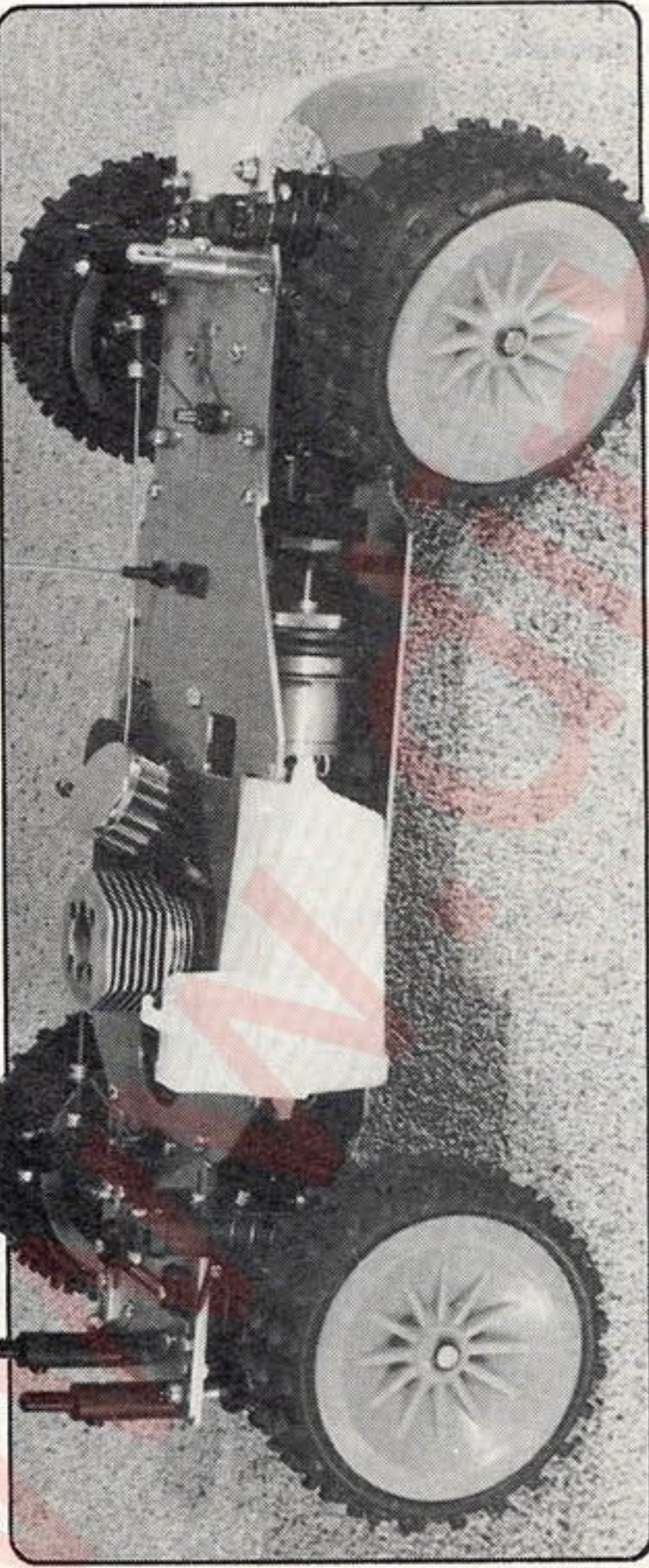

- PB 32 Basic Mustang X3 (No Centre Drive) ..... £247.24
- PB 32A Mustang X3 (with Solid Centre Drive) ..... £275.00
- PB 32C Mustang X3 (with 2 Speed Automatic Gearbox) . £285.00
- PB 32B Mustang X3 (with Adjustable One Way Centre Diff) ..... £295.00

All Centre Drives are available separately and may be interchanged in only two or three minutes

## PB ACCESSORIES

- NEW 23/115 Hi-Flow K & N Air Filter Kit ..... £9.59
- This offers filtering down to 2 to 5 microns with minimum air restriction. The filter is washable and comes complete with a sachet of special oil for use after washing. The moulded-in support fits most carburettors and a tie wrap is provided for securing the filter. — A really professional product.
- NEW PR08, PR09, PR10 — Decal sheets for Nova, Mustang X3 and Mini Mustang ..... £1.00 for each sheet
  - NEW PR01 "PB Racing" Banner (self adhesive) 1 metre long ..... £1.10



**PB racing products Ltd.**

Downley Road, Havant, Hampshire, PO9 2NJ, England Telephone: Havant (0705) 492310  
Telex: 86736 SOTEX G for PB Racing Fax: 0705-492320

SUPPORT YOUR NATIONAL ASSOCIATION JOIN THE B.R.C.A. 6 PARK WAY QUEENSBURY BRADFORD BD13 2HU



## NOVA ROSSI NEW RANGE FOR 1987

NEW GOLD HEAD (TESTA ORO)

NEW SILVER HEAD (ECONOMIC)

- 24/402 Testa Oro — Top Spec. .... £160.00 inc. VAT
- 24/401C Testa Rossa — Chromium Crank .... £139.95 inc. VAT
- 24/401 Testa Rossa — Unplated Crank ..... £127.00 inc. VAT
- 24/404 Economic — Fantastic Value ..... £ 80.00 inc. VAT

All the above are with S.G. type crankshaft but fully threaded crankshaft types are available

Full range of spares for all engines is stocked — PB know how important spares and after sales service backup is. We'll keep you racing.

# Mini Mustang



NEW LOCK STOP'S 02/61 ONLY £0.43p FOR TWO INC. VAT

- 2 Wheel Drive — PB28 £139.95 inc VAT
- 4 Wheel Drive — PB29 £159.50 inc. VAT
- 4 Wheel Drive 2 Speed — PB30 £179.97 inc. VAT

## MINI MUSTANG WINS NATIONWIDE

MORE THAN 50% OF THE CARS IN THE TOP FINALS AT THE FIRST TWO BRCA NATIONAL SERIES RACES WERE MINI MUSTANGS!

MINI MUSTANGS WIN THE FIRST TWO BRCA NATIONAL SERIES RACES

# MORLEY MODELS

10-12 MORLEY BOTTOMS, LEEDS, LS27 9DQ  
Tel: (0532) 522693 - 526848 Closed All Day Tuesday

CONGRATULATIONS to Morley Models' drivers:  
Gary Marsden Chaulky Dave Allen  
Newby Hall F.T.D. 3rd & 4th A Final  
Northern League Championships (Woodvale)  
F.T.D. & 1st A Final  
BRCA National (Woodvale)  
F.T.D. 2nd A Final

Lunch: 12.30 till 1pm

MAIL ORDER AND  
BUGGY  
SPECIALISTS

2WD IC BEGINNERS OFF-ROADER

THE MANTUA DEMON BIG BEAR PART BUILT INC.

PICCO 21 BUGGY MONOCOQUE CHASSIS. DIFFERENTIAL PLUS MANY OTHER UNIQUE FEATURES

£199.99

### XTALS

27Mhz for all 2ch sets  
Solids £4.50  
Splits £4.50  
All colours stocked  
Buy any 5 pairs  
GET 1 PAIR FREE!

### JUNIOR KITS

Bigwig  
Boomerang  
Hornet  
Ninja  
Samurai  
£4.99 ea.

NEW IN STOCK  
Introducing the MANTUA T4 Buggy Engine designed with economy in mind  
SG Crank Large Head Slide Carb £99.95

## PAMPER YOUR 'CAT' WITH TMS BOLT-ON GOODIES

### CAT 1

Rear Widening Kit, includes all fibreglass parts and accessories to widen car  
£9.95

### CAT 2

Rear shock mount to fit standard or for use with Cat 1  
ONLY £2.95

### CAT 3

Front Bumper Polycarbonate  
£2.75

### CAT 4

New improved steering link (T116) Slightly thicker!  
£1.10

\*\*\*\*\*  
\* IF BOUGHT TOGETHER — CAT 1-4 SAVE £2.00 — PAY £14.75 \*  
\*\*\*\*\*

### MINI MUSTANG PARTS

MSTG 1 Steel Shafts pr £4.95  
MSTG 2 Body Shell ... £9.95  
MSTG 3 One Way Roller Driveshaft ..... £18.95  
MSTG 4 Polycarbonate Front Bumper ..... £4.95  
MSTG 5 Front Shock Mount ..... £5.48  
MSTG 6 Rear Shock Mount ..... £5.48

### OPTIMA

Standard and Spares in stock  
TMS Goodies  
Final Pinion Steel ..... £3.95  
Front End Bracket ..... £3.95  
Front Shock Mount ... £3.95  
Rear Motor Guard ..... £4.75

### BUMPERS POLYCARBONATE

Boomerang ..... £3.95  
Bigwig ..... £3.95  
Falcon ..... £3.95  
Hornet ..... £2.95  
Rough Rider ..... £2.95

### BATTERY CONNECTORS

6 x Pins only 75p  
6 x Sockets 75p  
Pack as Picture 75p



TS-2211 FRONT TYRE for £6.50 HOT-SHOT RC10  
TS-2212 REAR TYRE for £6.50 HOT-SHOT WILD-ONE  
TS-2213 REAR TYRE for £6.50 FROG — HORNET GRASSHOPPER  
TS-2214 REAR TYRE for £6.50 RC10 YOKOMO SCORPION MARUI

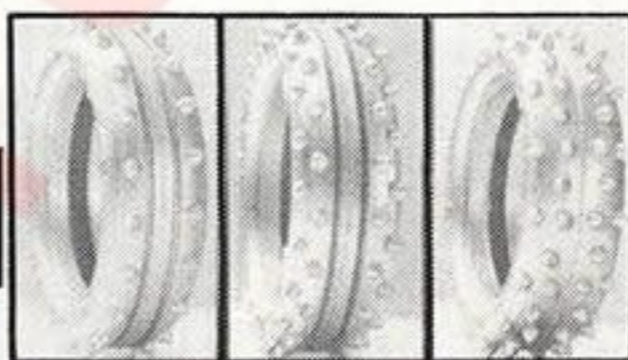

TS-2210 TS-2220 TS-2230  
FRONT TYRE FOR FOX — WILDONE £6.10 (fit WS-661 for RC10)

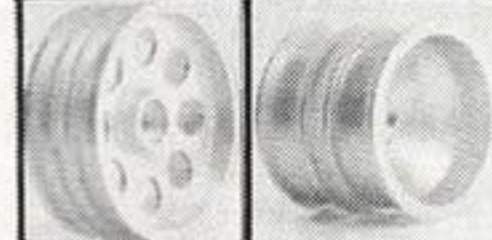

WS-661 one piece FRONT WHEEL for RC10 FOX—WILD-ONE (fit TS-2210-30) £2.95  
WS-662 one piece REAR WHEEL for RC 10 (fit TS-2214) £3.95

### NEW

TS 1121  
TS 1122  
Pin Spike  
Fit PB, CAT, Boomerang etc.  
£4.50 pr.

TS3314 (same as 3313) to fit Associated £6.50. Jackman adjustable wheels £6.50. All prices per pair.

★ STOP PRESS ★ STOP PRESS ★ STOP PRESS " STOP PRESS ★

## IC GARBO MASTER III

FOUR-WHEEL DRIVE — INC. 3 DIFFS  
1/8th IC OFF TOP COMPETITION BUGGY  
IN STOCK NOW — PRICE £299.00  
RING NOW FOR MORE DETAILS  
ALSO RANGE OF SPARES IN STOCK



POSTAL CHARGES:  
£2.00 Kits and Deals; 80p on all orders under £10.00

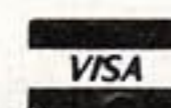

STOP NOW SEE

# SRM Racing

140 West Street, Fareham, Hants. Tel: (0329) 234262

**Full Trade Terms Available**  
Please Contact Us

**Send S.A.E. For Our New Up to Date Catalogue**

### NEW TUNE UP ACCESSORIES

- Transform the handling of your CAT — new Shock Diaphragms — convert your shocks to constant volume - less leaks - consistent performance - set of 4 £1.65, also fits RC10 shocks.
- Alloy Wheels to fit Tamiya 4WD and Mini Mustang - fits CAT with our special adaptors - large diameter - standard widths plus wide track rear - gold anodised. Takes all Idow profile tyres - Cat - Dynamite - Tamiya - Option House Pro Line £12.95 pair.
- Mini Mustang narrow front track conversion for SRM roller hubs - allows use of CAT tyres. Kit contains 2 alloy axle blocks - 2 roller axles £11.95

### JACRABBIT 1/4 Scale Jacrabbit Off-Road Buggy

Now Available exclusively from **SRM RACING**

Just add Transmitter and Receiver  
Uses 2 Star & 2 Stroke Oil

**Price Approx £895**

Road Tyres Available from Stock

### TWISTER MODIFIEDS

Now the fastest seller in America

201 2WD All Tracks 202 2WD High Grip Tracks  
402 4WD High Grip Tracks 501 4WD Oval Spec - our fastest!

NEW 501T Triple Wind - Very fast and economic  
401 4WD All Tracks - loves CATS, Mustangs, Optimas, Winner of 3 International Races this Year (so far).

All Twisters have capacitors fitted and are supplied with Super Flex Leads. Price £40 each  
FREE Motor Tub with every Twister ordered

### TUNE UP ACCESSORIES

Available to fit:  
Frog - Wild One - Blackfoot - Falcon - Optima - CAT - Hot Shot  
Boomerang - Supershot - Bigwig - Fox - RC10 - Mini Mustang - Ultima

Our list is growing all the time — are you updated?!

### MINI MUSTANG All PB Spares in Stock including new & updated accessories

- NEW Rear wing mounts (wing kit to suit 2-75) £3.45
- Ballraced Belt Tensioner Kit (alloy) £5.95
- Alloy Layshaft Bearing Holder £1.95
- Front Roller Clutch Hubs —
- NEW Improved Design - pair £21.95
- Improved Roller Hub Axles - Locknut Fitting - pair £4.95
- Ground Steel Servo Saver Posts - use with Kimbro Servo Saver £5.45
- PolyBone Drive Shafts - use without spacer - pr. £3.95
- Wide Track Adaptors - set 4 - Use W/One Wheels £5.95
- Ball Pivot Bottom Shock Mounts - set 4 £3.70
- Heavy Duty Front Track Rod set £5.75
- Set 8 Camber Adjusters £1.95
- Servo Saver to Servo Arm 2 Links 95p
- Chassis Screw & Nut set 95p
- NEW STYLE Cast Alloy Axle Blocks F or R - pair £8.50
- NEW Set 4 Alloy Shock Pistons - firm or soft £3.45
- Class One Body from USA with Wing £10.95
- Alloy Wheel Bosses - set 4 £8.50
- Spring Steel Boss Pins - pack 5 £1.25
- Chassis Mounted Aerial £3.95
- CAT Spur Gear Adaptor £3.95
- EXCLUSIVE SRM 2 Speed Pinions - inc. Gear Chart
- 10/12 12/14 14/16 16/18 20/22 - each £3.95
- 10/14 11/15 12/16 14/18 16/20 18/22 - each £3.95
- 640P Spur Gear Adaptor (108T only) £3.95

### RC10 ASSOCIATED Still the best value kit available

Superb Performance Excellent Reliability  
Basic Kit Rolling Chassis - Long Body - Free Bumper £120

Complete Kit includes 28T Motor - Resistor Speed Controller - Fast Charge Card - Wing - Free Bumper £142.50

High Grade Ball Race Set £39.95 (£32.50 with complete kit)

We can supply package deals to suit your individual requirements. Your choice of Radio, Nicad, Motor, Body, Speed Controller, Charger

RC10 Kits & Package Deals Insured and Post Free Ring Now

The complete range of factory spares are available from stock - check our prices. SAE for comprehensive Accessory list

### NOW AVAILABLE LASER Laser Computer matched SCR NICAD PACKS

QUITE SIMPLY THE BEST AVAILABLE  
Winners of countless Open Meetings. 1/10th & 1/12th Indoor & Outdoor  
11 National UK Championship Titles. 1/10th & 1/12th in the last 2 years.

AVAILABLE EXCLUSIVELY FROM SRM  
PRICE £29.95 POST FREE per pack

Comfet Speed Controller with reverse £65.00  
Capacitors - High Tolerance - Fit 2 per motor. Pack 4 £1.00

Designer Decals from

*AutoGraphics*

Now in stock  
S.A.E. for Details

### NEW "POLYBONES" £3.95 PAIR

Stainless Steel & Delrin Shafts available to fit the following cars  
Mini-Mustang, Associated RC10, AYK Bobcat, Hotshot/Supershot Front, Hotshot/Supershot Rear, Boomerang/Bigwig Front & Rear, AYK Radiant, Dogfighter Front, Dogfighter Rear, Optima, New Falcon and Striker, Heavy Duty Conversion Kit £14.95, Fox Conversion Kit £14.95

### NICADS 7.2V PACKS

Schumacher: Custom SC £19.95, SCR Reds £18.95  
CS Selected SC £24.95 Selected SCR Reds £23.95  
Parma Matched Packs - with 7.2v Lead £19.95  
MiH "Pushed" & Matched SC's £29.95

### NOW STOCKISTS OF 1/12 ACCESSORIES EXCLUSIVE TO SRM

TDC Chassis for 'C' Car £19.95 post free (inc. 'T' Piece)  
1/8 thick for maximum strength and low C of G.  
Associated & Parma Tyres Donuts & Ready Trued  
Kimbro 48-50-52 Spurs - Tyre Horn - Wing Ties  
Servo Savers - Associated & Parma Bodies  
NEW Associated RC 12L - now in stock  
1986 World Championship Winner  
All Associated 1/12 Spares Available

### NEW SRM "STUNNER"

35T Yokomo £13.50 Selected, Balanced & Trued

NEW TWISTER 1/12th MODIFIEDS  
£40 each inc. Free Tub  
27T Double or 27T Quad

### SCHUMACHER CAT

Full range of spares and accessories always in stock

NEW FROM CECIL  
XL Long Wheelbase conversion inc. chassis - bell - body - undertray £25 Winner Reedy International & French G.P.

- Lowered rear suspension mount
- Anti-stop steerign posts
- One way drive shafts
- Front differential
- Integrator & diff thrust bearing
- Long gearbox/bumper screws & nuts

### COMING SOON FROM SRM

- One-way roller hubs (uses Mustang/Hotshot wheels)
- Wide track adaptors - CAT wheels
- Wide track adaptors for Mustang/Hotshot Alloy Wheels
- Belt adjuster
- Adjustable shock clamps (in stock now)
- Full width front bumper
- Front castor adjusters
- Steel suspension balls

### OFF ROAD MOTORS & ACCESSORIES BRCA Approved for 1987

Standard Class all at £11.95 each  
SRM SCREAMER 28T Timed - Dynotuned - Selected  
SRM SCORCHER 27T Timed - Dynotuned - Selected  
PARMA 28T Pink Label & 27T 'K' Stock - Spirit 600 30T  
DEMON New style 27T SCHUMACHER Yoko 27T  
PARMA Enduro - Sprint - Super Sprint - Oval . £40 ea  
Armatures as above £17.65  
DEMON Double 22T & Double 20T £20 ea  
Quad 19T & Triple 16T £25 ea  
NEW Power King £40  
SCHUMACHER Single 19T £25  
Reedy Specs (as available) £40  
TRINITY NEW modifieds now stocked. Call for availability

### MAIL ORDER SPECIALISTS



Please add 50p to all orders.  
Kits £1.50 p&p. Visa & Access

CALL US FIRST

OVERSEAS SHIPPED AT COST

Updated Catalogue sent with all Orders



# TEKIN

## ELECTRONICS SPEED CONTROLS

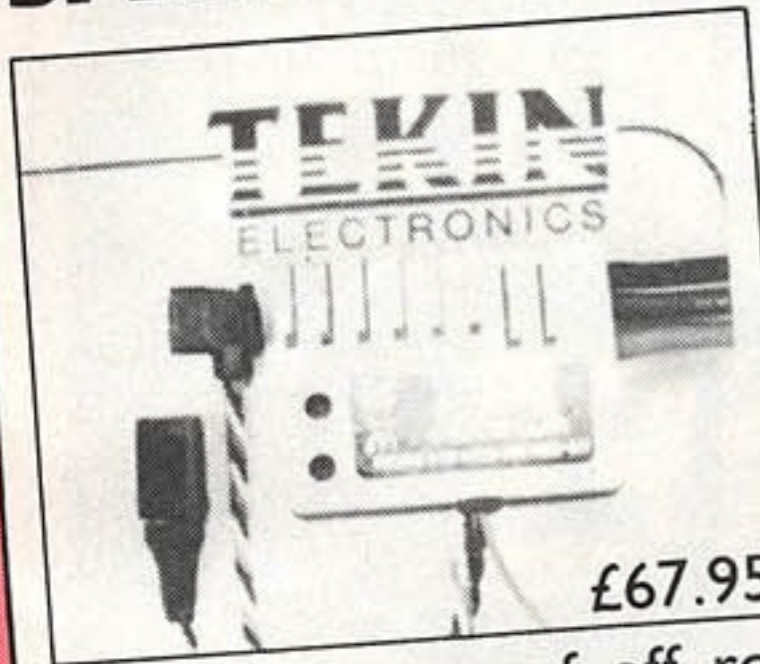

£67.95

**TEKIN STANDARD**  
Compact, Reliable,  
Designed to withstand

the punishment of off road racing. Built in Rx  
Regulator. 4-10 cells, heat sinks recommended  
£9.50 set

TEKIN PRO £119.95

Premium Mosfets & High Grade Electronics  
Throughout

### THE WORLD CHAMPION'S CHOICE

TEKIN PRODUCTS are used by racers  
everywhere at all levels of competition

Available Soon  
PRO RECEIVERS  
World's Smallest  
& Lightest  
Available on  
27/29/40/72/75  
MHZ

### PULSE CHARGERS



£59.95

Designed to extract the  
maximum amount of per-  
formance from your nicads  
with the minimum amount  
of hassle. Set it and forget  
it. An international  
favourite.

BC200 PRO £129.95. New professional model  
with LCD digital display calibrated in amp-  
minutes, LSI circuitry, output jacks for volt/  
ammeter.

Send SAE for  
full Spec Sheet

## SRM Racing

**UK & EUROPEAN DISTRIBUTION FROM THE RACERS SOURCE**  
140 West Street, Fareham, Hants PO16 0EL, England  
0329 234262 Full Trade Terms Available

### 4WD CONVERSION KIT FOR ASSOCIATED RC10

FITS

- STANDARD •
  - TDC •
  - GRAPHITE •
- CHASSIS

# MIP

BEST ENGINEERED

## £135

Full Spares Back-up

Send SAE for  
full Spec Sheet

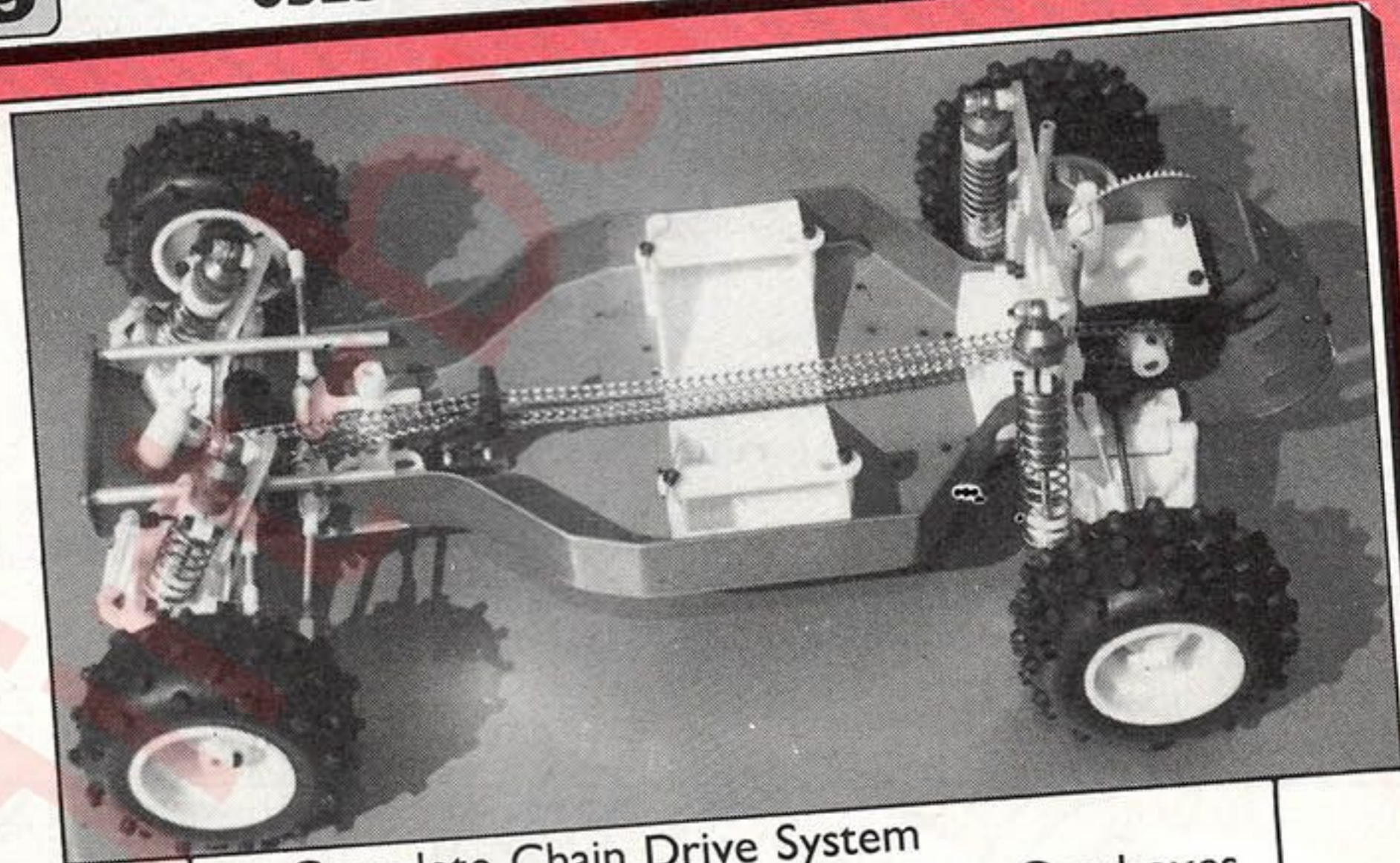

- Complete Chain Drive System
- Ball Raced Front & Rear Compact Gearboxes
- Adjustable ball differentials
- Easy fit with minimum of drilling
- Front U/J Driveshafts
- Uses stock suspension arms
- New Axle Blocks
- Roller Hub Conversion Available for front axles

**UK & EUROPEAN DISTRIBUTION FROM THE RACERS SOURCE**  
140 West Street, Fareham, Hants PO16 0EL, England  
0329 234262 Full Trade Terms Available

## SRM Racing



# PROUDLY PRESENT... THE EVER READY CLASSIC SERIES

In conjunction with

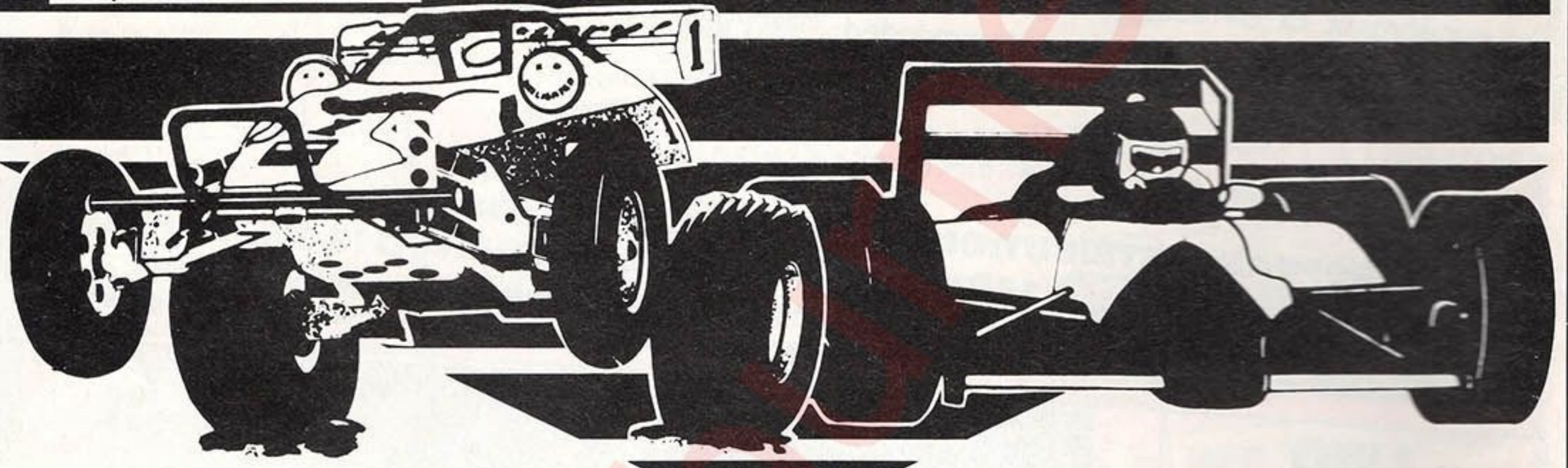

### EVER READY INTERNATIONAL OFF ROAD CHAMPIONSHIP FOR 1/10 ELECTRIC OFF ROAD CARS

AT  
Southend Radio Control  
Car Club Track  
25/26th July 1987

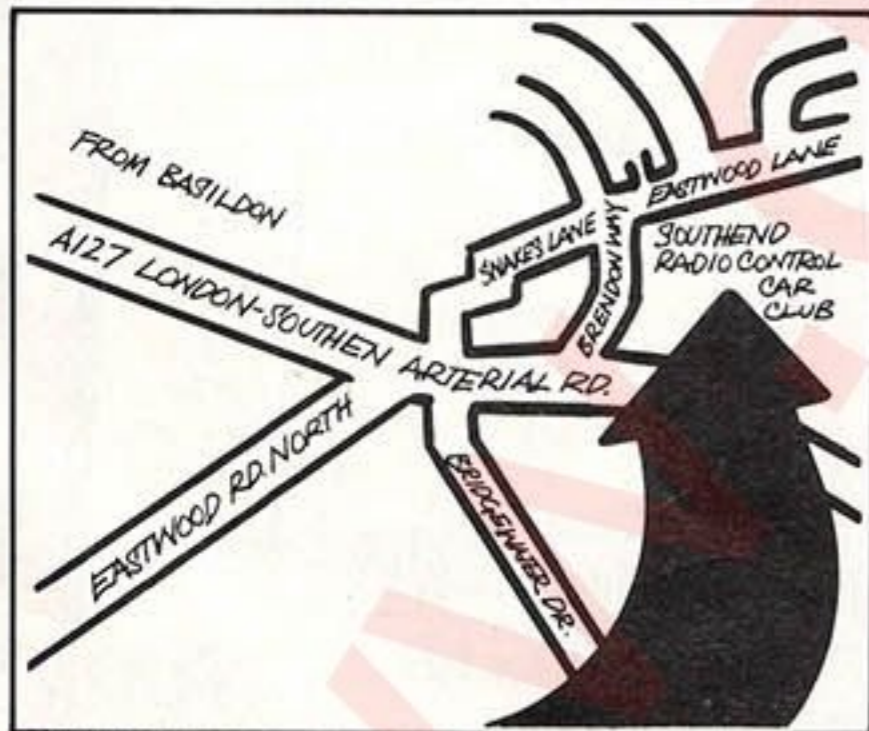

Entries to: John Newton,  
4 Aylesbeare, Southend-on-Sea,  
Essex SS3 8AE.  
Tel (0702) 585770

Subsidised accommodation provided  
sufficient warning is given.

### EVER READY BRITISH NATIONAL CHAMPIONSHIPS FOR 1/8 CIRCUIT CARS

AT  
Weston Shore Circuit  
Southampton  
29/30/31st August 1987  
Entry Fee: Adult £5.00, Junior £2.50

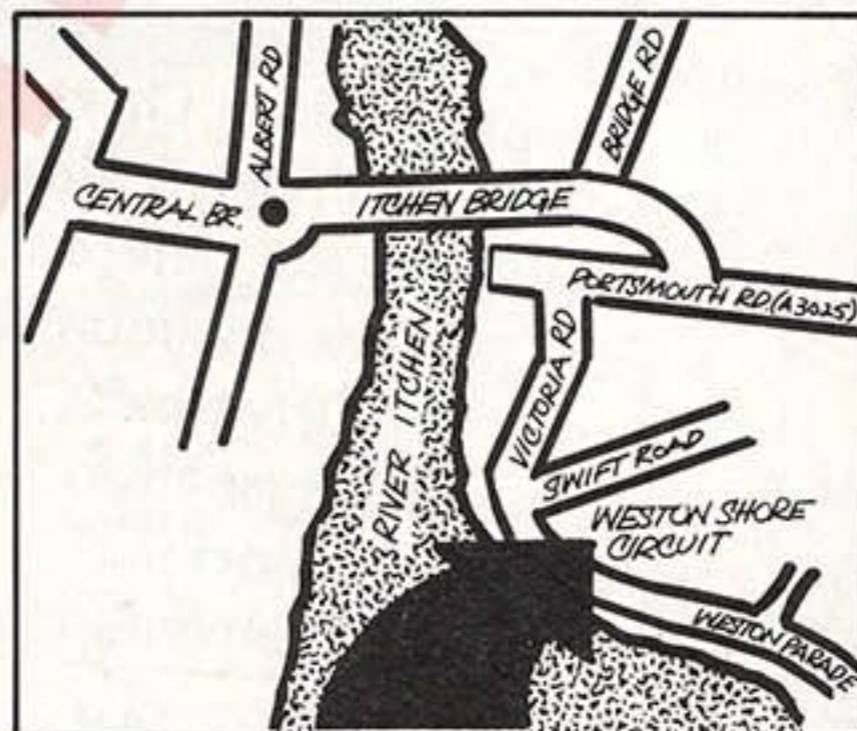

Entries to: Ian Braithwaite,  
21 Ruby Road, Bitterne,  
Southampton  
Tel (0703) 433567

(s.a.e. for confirmation)

On Saturday night there  
will be a Riverboat Shuffle  
which entails a boat trip into the  
Solent and up one of the picturesque  
rivers that run into the Solent.  
THIS TRIP OF COURSE WILL  
BE FREE!

### EVER READY BRITISH GRAND PRIX FOR 1/12 RADIO CONTROL CARS

AT  
Gateshead International Stadium  
Leisure Centre  
24/25th October 1987

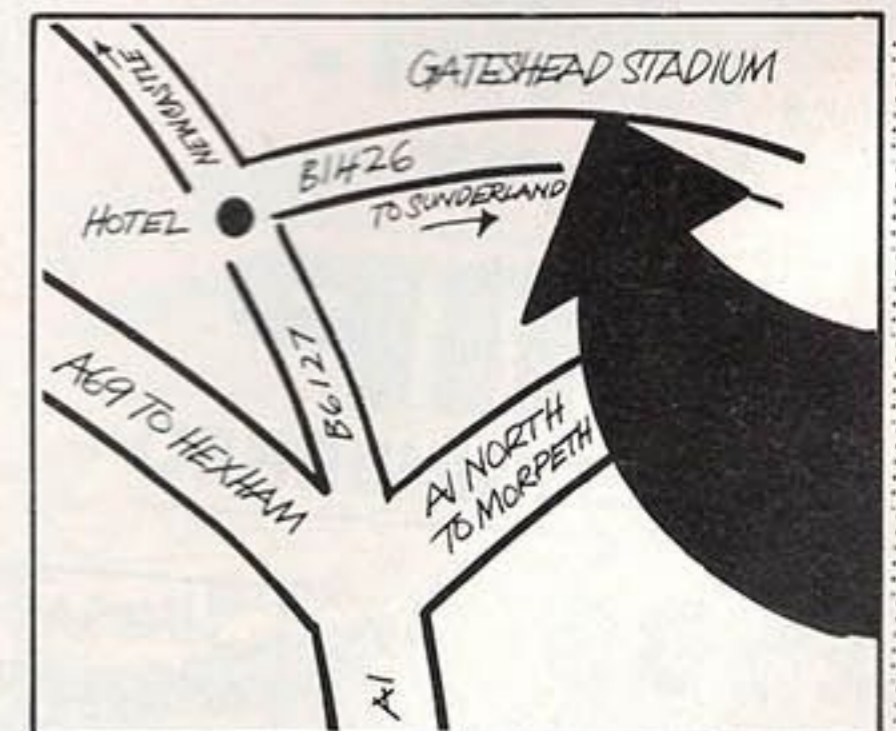

Entries to: Peter Waites,  
38 Rosedale Court, West Denton,  
Newcastle-upon-Tyne NE5 2JH  
Tel: 091-264 6278 (evenings only)

Entry Fees: 2 Nights Hotel plus 2 days Racing £32.00  
1 Night Hotel plus 2 days Racing £22.00.  
Entry on the day £6.00





# ESTABLISHED 1960 MANSSEL'S

Open Mon - Sat 9am - 6pm  
Half day Wednesday

**MANSEL'S CORNER · PALACE AVENUE · PAIGNTON  
DEVON TQ3 3EN Telephone: 0803 521767**

**ALL DEALS INCLUDE KIT, RADIO, BATTERY SLOW CHARGER.  
FOR FAST CHARGER INSTEAD OF SLOW ADD £10**

**NEW HOTSHOT II**

Please phone for details



**Monster BEETLE  
CAR £88.95  
DEAL £144.95**

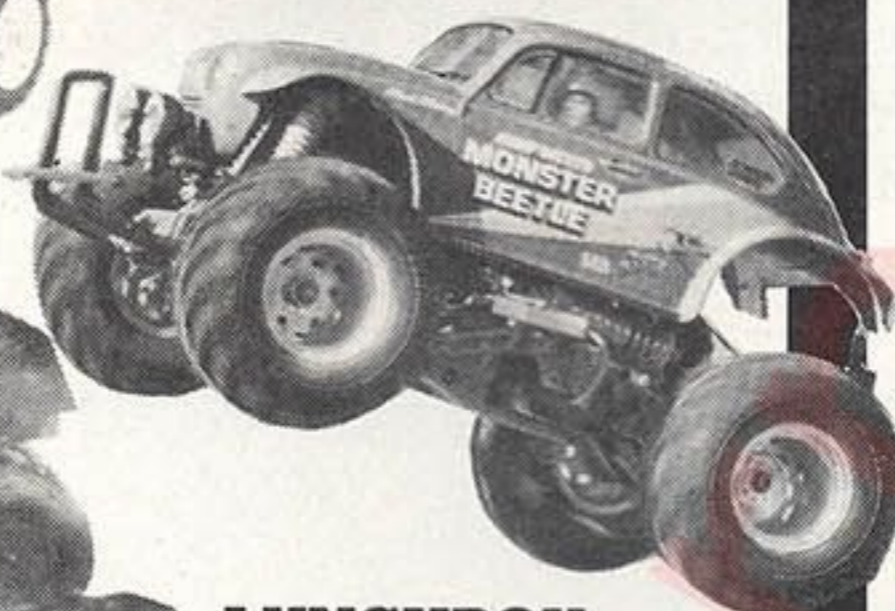

**NINJA  
CAR £94.95  
£152.95**



**LUNCHBOX**

Please phone for details



**RADIOS**

- NEW Attack BEC ..... £47.95
- Attack BFR ..... £62.95
- 2LGX ..... £119.95
- 4ch Challenger  
27MHz ..... £134.95
- ACOMS  
Techniplus ..... £42.95
- Techniplus BEC ..... £49.95
- Acoms 4ch ..... £109.95

**MOTORS**

- Le Mans 600E ..... £11.95
- Le Mans 480 Gold ..... £35.95
- Le Mans 360 PT ..... £29.95
- Le Mans 240G ..... £39.95
- Spirit 600 ..... £11.95
- Tamiya Standard 540 .... £9.99
- RS540SD Sprint ..... £20.99
- RS540SD Endurance .... £20.99
- Technipower ..... £30.00
- Technituned ..... £30.00
- Parma Oval Racing ..... £37.95
- Demon Power King ..... £40.00
- Demon Doublewind .... £12.00
- Demon 1X228015 ..... £12.00
- Demon Quad 19T ..... £25.00
- SRM Twister ..... £40.00

**CHARGERS**

- 6v, 7.2v or 8.4v Slow  
Chargers ..... £6.99 each
- MFA Charging Monitor..£16.95
- MFA Twin Charger ..... £29.95
- MFA Mains Rapid Charger . £32.95

**SPARES, SPARES, SPARES**  
For Tamiya, Marui, Kyosho and Mardave

**MODIFICATION PARTS**

- Hotshot HP Suspension Set £16.50
- Hotshot hardened drive shafts £4.95
- TMS Motor Guards (Optima) £4.75
- TMS strengthened bumpers for  
Boomerang and Bigwig .... £4.15
- Many more from TMS, Option House and SRM. Please phone for details.

**TYRES, TYRES, TYRES, TYRES**  
Are your tyres tired!! We stock Tamiya, Parma, TMS, Dynamite, Option House, Kyosho and Mardave

**TAMIYA**

	Acoms Techniplus	Acoms Techniplus BEC or New Futaba Attack BEC
Hornet .....	£53.95	
Deal .....	£109.95	116.95
Striker .....	£58.95	
Deal .....	£114.95	£122.95
Falcon .....	£64.95	
Deal .....	£120.95	£128.95
Blackfoot .....	£79.95	
Deal .....	£135.95	£143.95
Monster Beetle .....	£88.95	
Deal .....	£144.95	£152.95
Boomerang .....	£91.95	
Deal .....	—	£154.95
Hotshot .....	£110.95	
Deal .....	—	£172.95
Big Wig .....	£145.95	
Deal (with 7.2) .....	—	£215.95
Deal (with 8.4) .....	—	£225.95
Porsche 959 .....	£137.95	
Deal .....	—	£205.95
Tamtech complete	£141.95	
Bruiser .....	£205.95	
Deal Please phone for details		

**MARUI**

Ninja .....	£94.95	
Deal .....	£152.95	£159.95
Big Bear .....	£65.95	
Deal .....	£121.95	£129.95

**KYOSHO CARS**

Turbo Scorpion .....	£96.95	
Deal .....	£152.95	£160.95
Rocky .....	£99.95	
Deal .....	£155.95	£163.95
Optima .....	£123.95	
Deal .....	£179.95	£187.95
Optima Turbo .....	£185.95	
Deal .....	£241.95	£249.95

**BRITISH CARS**

New Mardave Mini Stocks .....	£39.95
Mardave Marauder .....	£49.50
Marauder with Irvine 20, silencer and filter .....	£97.50
Mardave Meteor .....	£55.00
Mardave Meteor with Ni-cad and Fast Charger..£77.00	
Mardave Meteor Deal .....	£126.95
Mini Mustang 4 wheel drive .....	£159.50

(Complete deals can be arranged on Marauder — ring for details.)

**BARCLAYCARD/ACCESS ORDERS BY TELEPHONE**

**SAME DAY DESPATCH**

**PLEASE ADD POSTAGE £2.75 KIT, £3.75 DEALS, 75p MOTORS & SPARES**

# HANDS ACROSS THE WATER

## TAMIYA MODEL MAGAZINE INTERNATIONAL

Tamiya Model Magazine International is the inspired choice for the plastic model enthusiast. All forms of scale modelling are covered including racing cars, military vehicles, boats, warships, aircraft and much, much more.

Published by Tamiya Plastic Model Co., the magazine is now produced by Traplet Publications Ltd.

All enquiries to Traplet Publications Ltd., Masefield House, Wells Road, Malvern, Worcs. WR14 4PA, England. Tel: (06845) 60561. Telex 334708 RCMAGS. Fax 068 45 3646.

Autumn issue available September 18th, make sure you get your copy, order it today.



Part of the massive production line at Tamiya, note how spotlessly clean everything is kept.



Two testing tracks for new Tamiya products, on the left 1/10th, on the right 1/12th and 1/24th.

Mr S. Tamiya and Mr T. Stephenson shake hands on the production award.

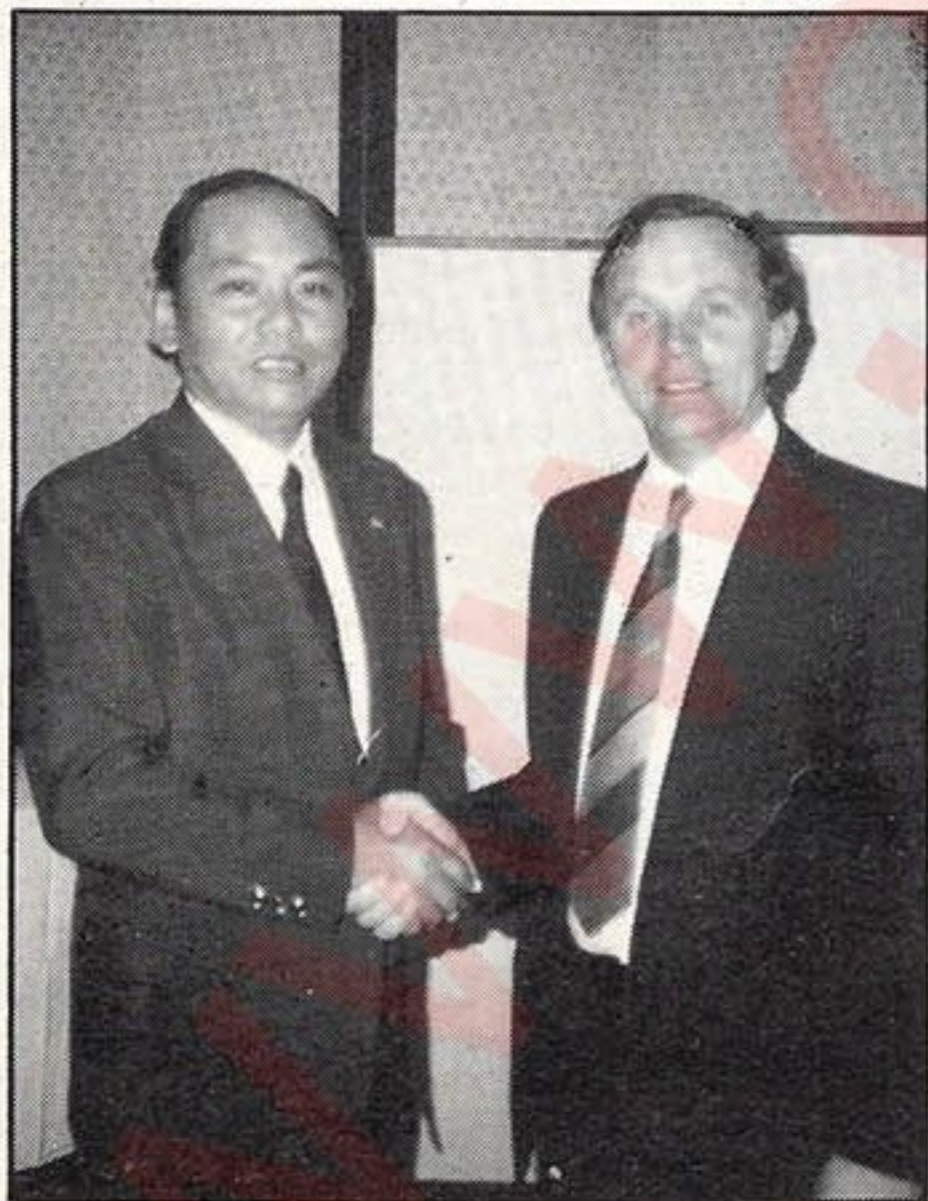

**TRADE MODEL SUPPLIES LIMITED**  
**DEANFIELD MILL, ASQUITH AVENUE,**  
**LEEDS, LS27 9QS. 0532 523023**  
**IMPORT/EXPORTERS OF MODEL GOODS**



ASK FOR **TMS** ACCESSORIES BY NAME

SEE YOUR LOCAL STOCKIST FOR THESE ITEMS PLUS MANY MORE

MANTUA/GARBO 1/8 OFF ROAD CARS: SOLE UK DISTRIBUTOR

Part No. 3301000



Has won many national championships worldwide, includes 4WD/3 differentials, disk brakes/hydraulic shock absorbers. See your local shop for more details.  
 Retail £299.95

T4 3.5cc  
 Rear Exhaust

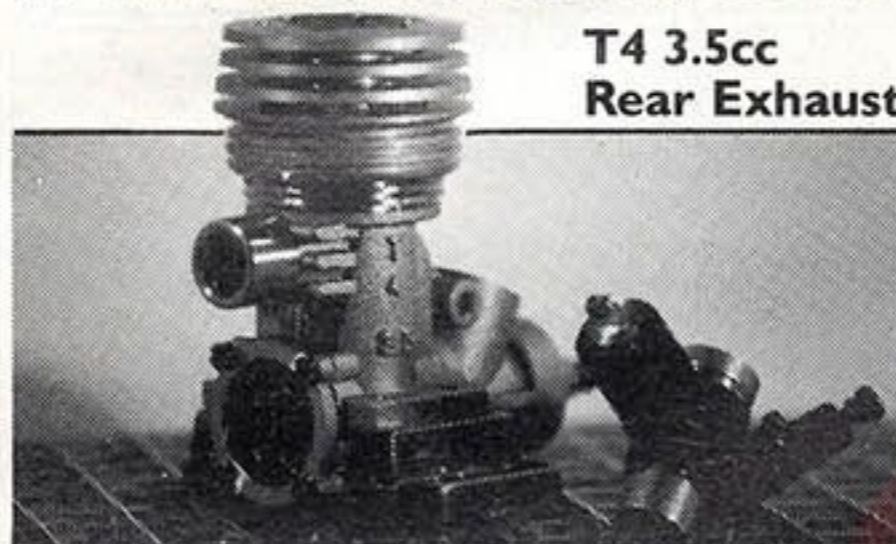

Part No. 62000

Retail £99.50

Part No. 22187



Includes Picco 2F Buggy Engine/Silencer/Air Filter/differential/independent suspension/monocoque chassis  
 Retail £199.95, superb value!

**MINI MUSTANG UPRATING PARTS**

Front or Rear Drive Shafts Carbon Steel  
 £4.95 pair



One Way Drive Shaft Carbon Steel; also for Hotshot  
 £18.95

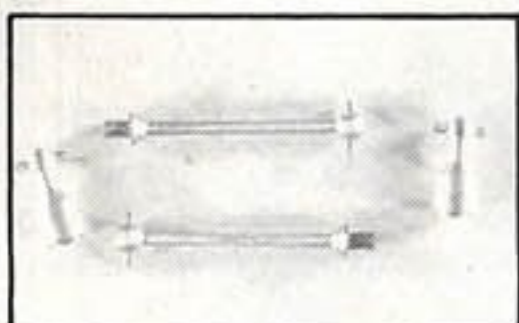

Front Bumper  
 £4.95

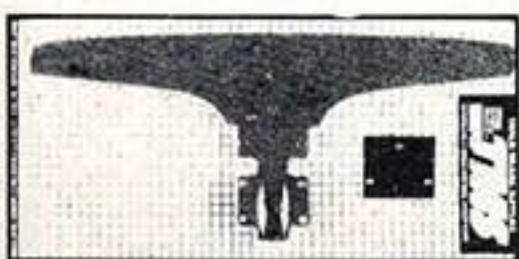

Front Shock Mount Made in Fibreglass  
 £5.48

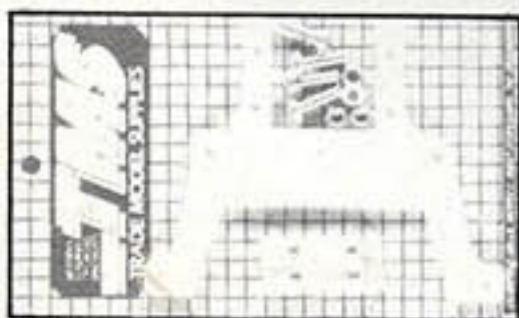

Rear Shock Mount Made in Fibreglass  
 £5.48



**FREWER POLYCARBONATE BODY SHELLS: SOLE UK DISTRIBUTOR**

£9.95

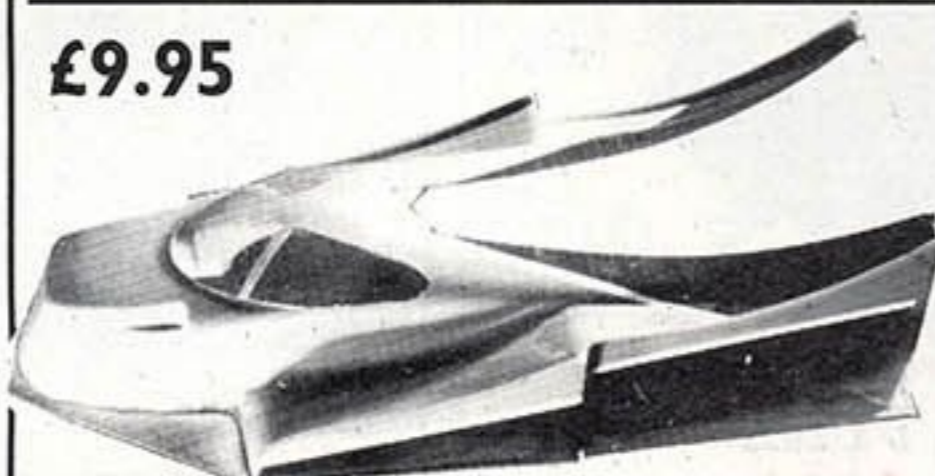

The shell is designed to allow the rear shocks and gear cover to protrude through the top of the shell. The rear body posts are to be exactly 2 1/2" long (we recommend TMS posts part no. BPA27). If necessary, trim the lip on the post that may or may not rub against the gear cover. After fitting the shell trim the base of the side pods level with the chassis plate. A good mounting place for the receiver to suit this shell is either on one side of the centre moulding or on top of centre moulding. (also speed controller)

AERODYNAMICALLY IMPROVES HANDLING

**1/10th Peugeot 205 Turbo**

Perfectly to scale to the extent that we have provided a separately moulded rear spoiler that attaches to the roof with wing buttons. Fits any chassis as rear wheel arch is unmarked. All necessary hardware to fit wing is included. £12.95

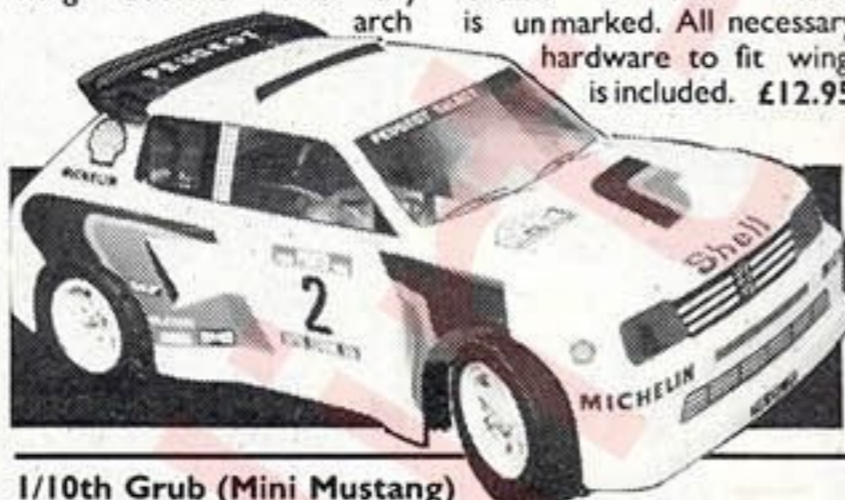

**1/10th Metro 6R4**

Made for the UK market by Frewer. This shell will fit almost any chassis as rear wheel arch is unmarked. Detail is perfect. A work of art to reproduce. £10.95



Rear wing also now available.

**1/10th Grub (Mini Mustang)**

Designed by Frewer of New Zealand to fit the Mini Mustang. This durable but lightweight body fits very snugly around the car to keep the dirt out. The shell is accurately outlined and therefore mounts in minutes. £9.95



**1/10th Pro-Tech**

Originally designed to fit RC10. This excellently produced body also fits perfect onto the Optima and Salute.



**NOW AVAILABLE TMS BUGGY BAG**

20 x 10 x 10 water resistant nylon. Central zip allows bag to be opened fully. Strong handles. Shelf insert for accessories to go underneath. Exceptional Value £9.95.



**SCHUMACHER CAT UPRATING PARTS**

Rear Widening Kit includes all parts as shown  
**INCREASE STABILITY**  
 £9.95



Shock Absorber Mount for use with Cat I and Standard width cars  
 £2.95



Replacement Front Bumper  
 £2.45

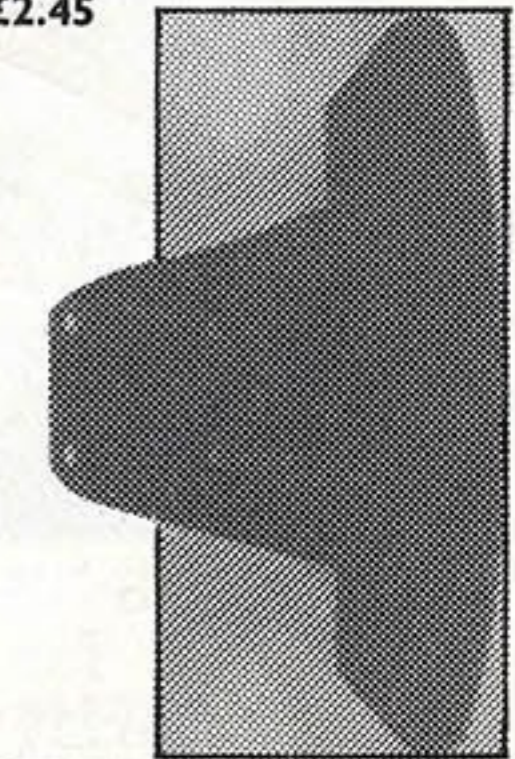

JUST SOME OF THE BODIES AVAILABLE TO FIT 1/10th. MANY MORE AVAILABLE. (ASK YOUR LOCAL SHOP TO ORDER YOU ONE NOW). ALSO AVAILABLE. VARIOUS SIZES 1/10 WINGS. 1/12 BODIES INC TOJ AND PORSCHE. 1/8 BODIES INC. ESCORT.

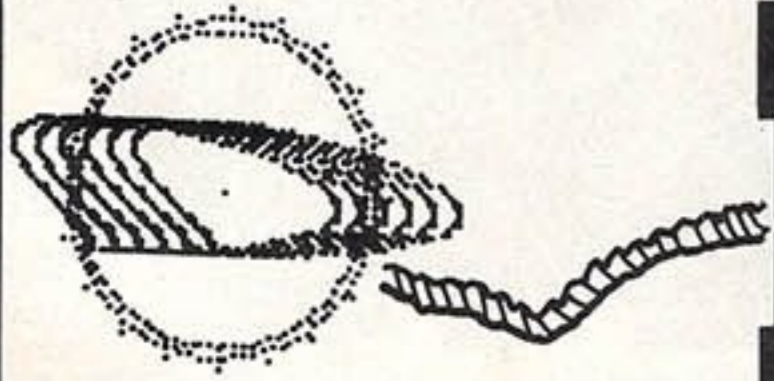

# DYNAMITE

## HIGH PERFORMANCE TYRES

For 1:10 Off-Road Racing Buggies

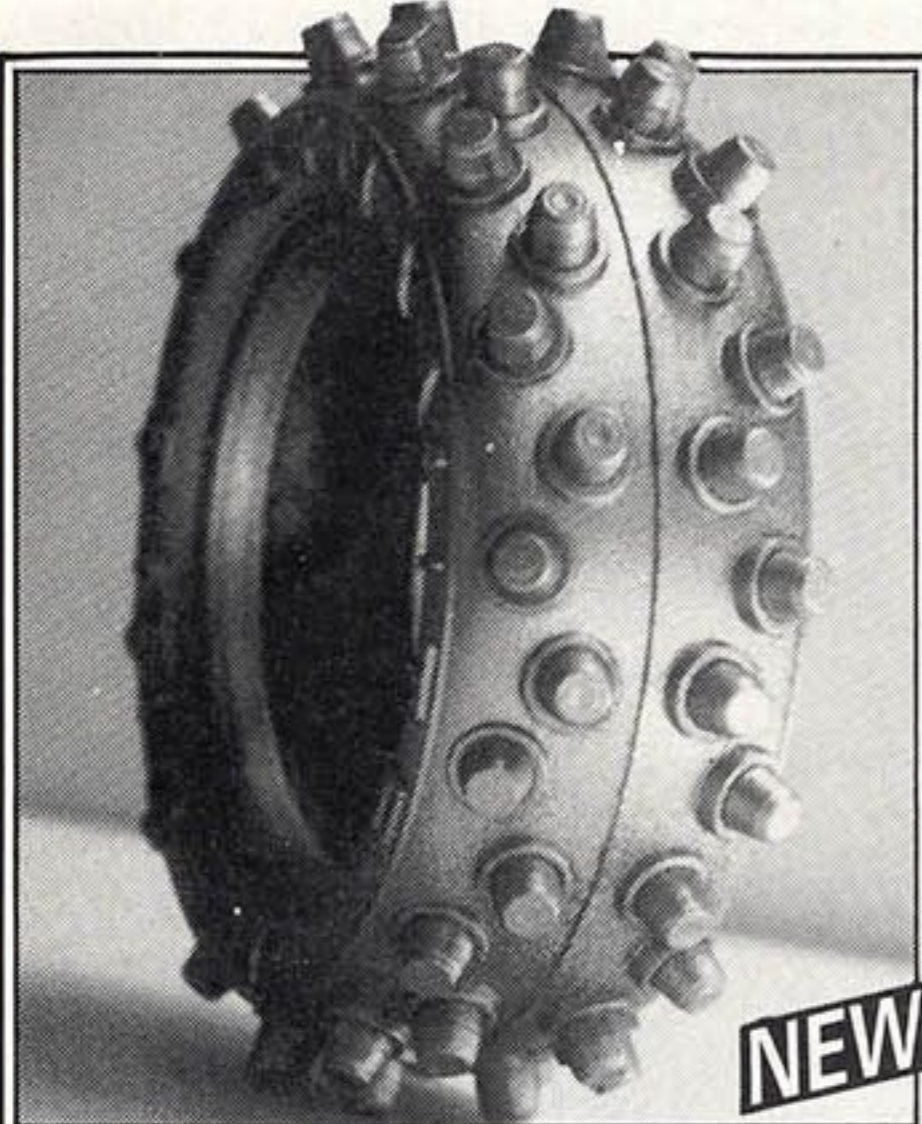

TS-3311  
FRONT TYRE  
for  
HOT-SHOT  
RC10



TS-3312  
REAR TYRE  
for  
HOT-SHOT  
WILD ONE

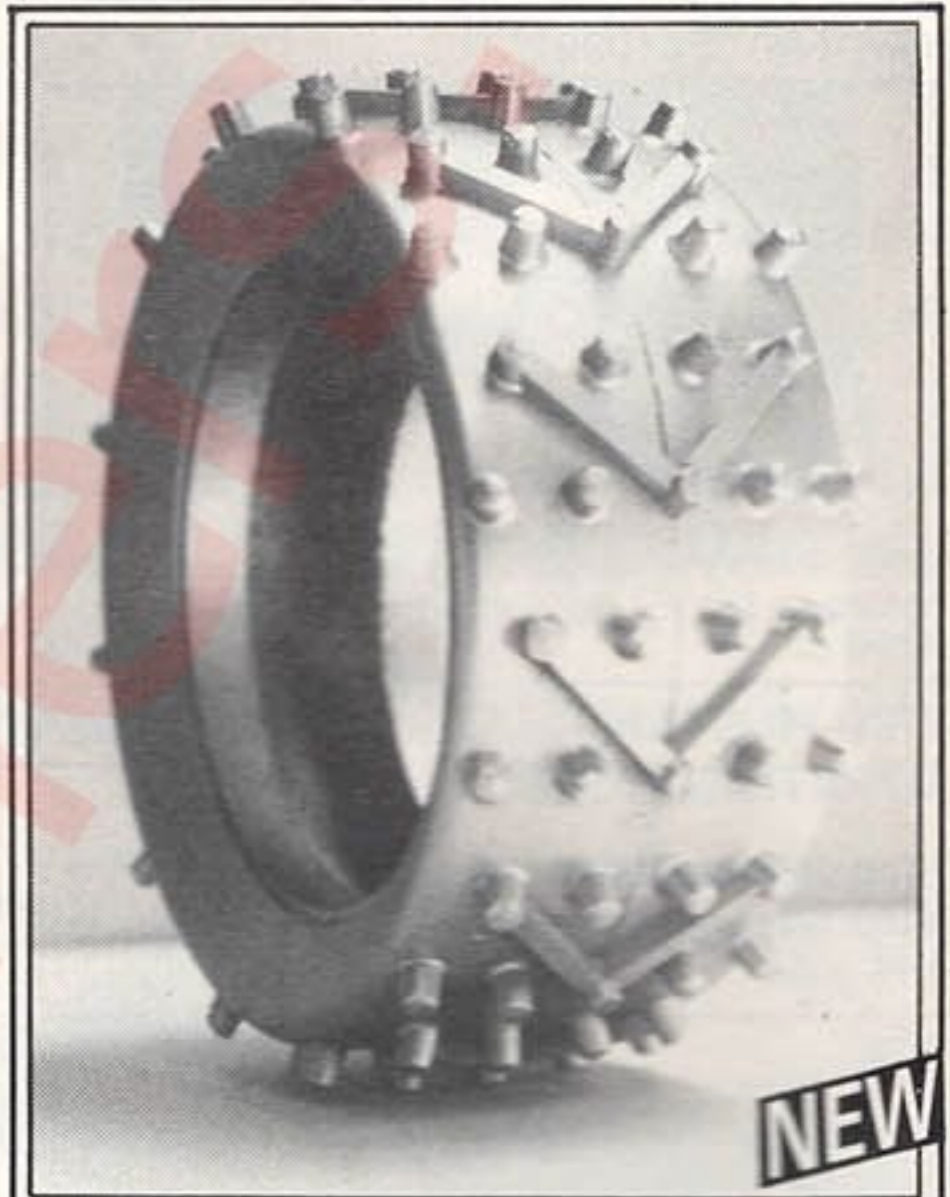

1/8 OFF-ROAD TYRES  
for  
PB and SERPENT

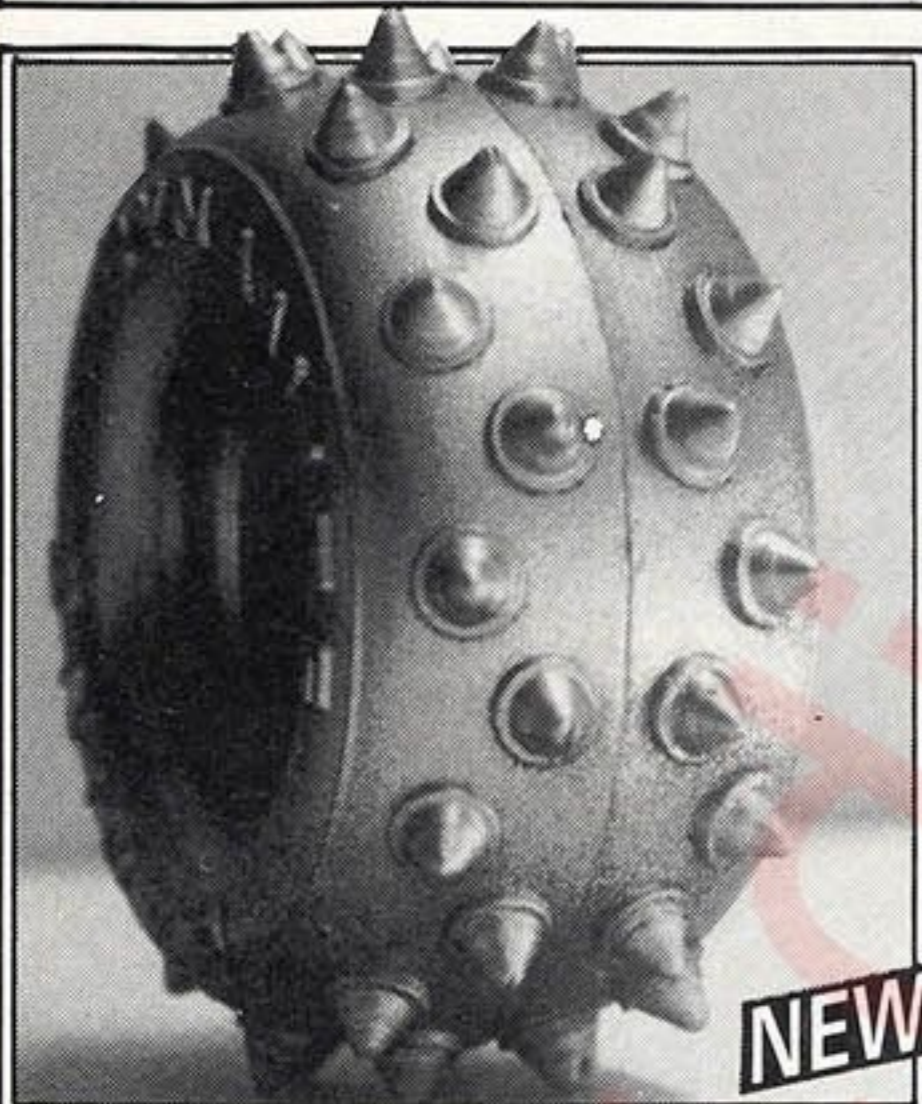

TS-3313  
for  
TAMIYA  
FROG-HORNET-GRASSHOPPER  
SUPERCHAMP ETC.

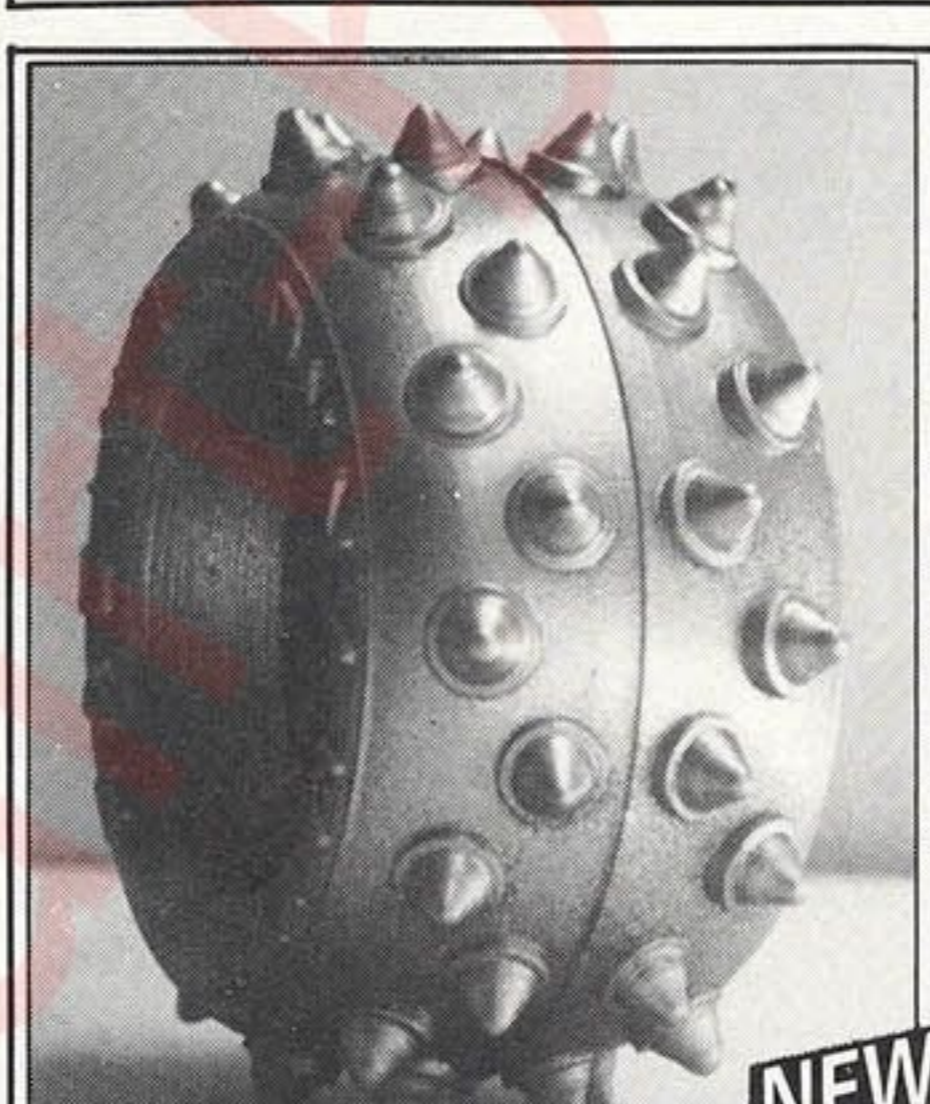

TS-3314  
for  
YOKOMO  
ASSOCIATED RC10

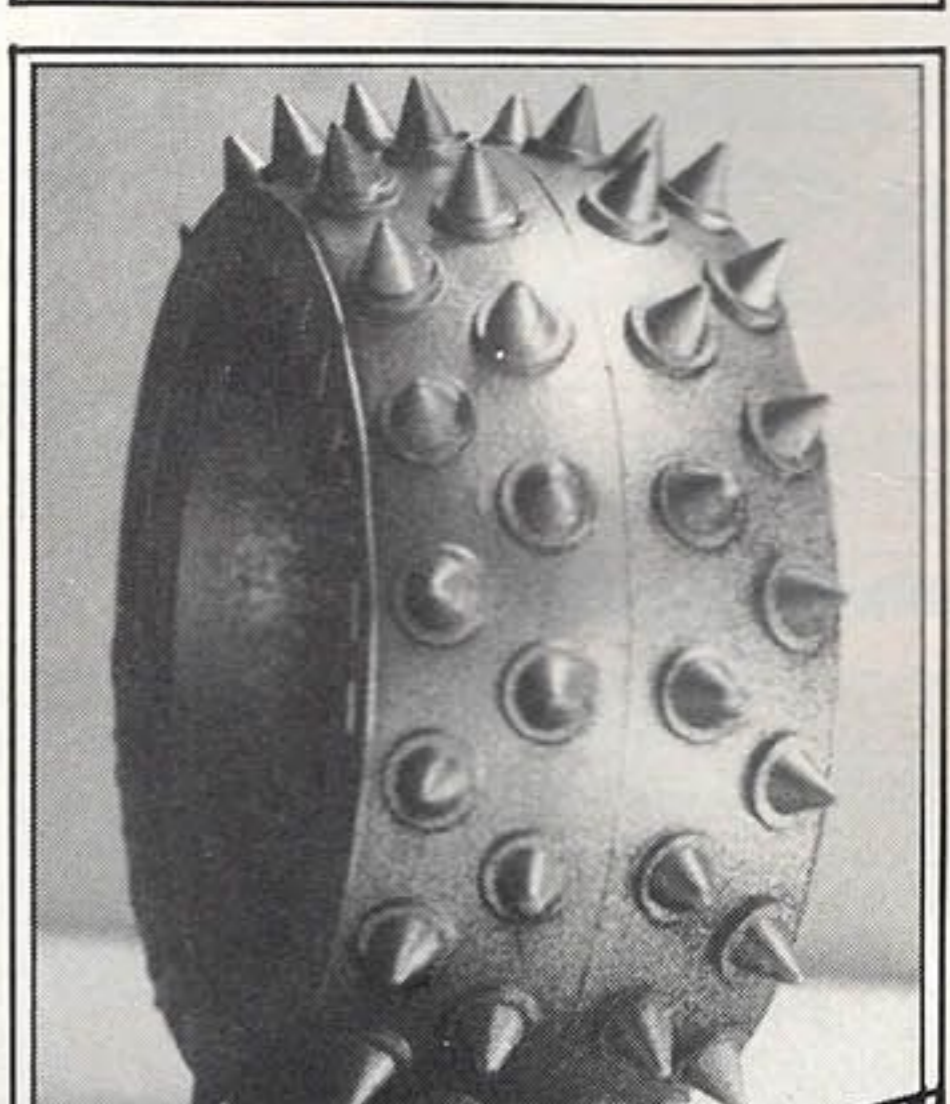

TS-22125  
REAR TYRE for  
HOT-SHOT, KYOSHO

### INFINITE TRADING CO.

RM.309 Summit Insurance Building, 789 Nathan Road, Kowloon, Hong Kong  
TELEX: 31672 TELEPHONE: 3-816323

AVAILABLE FROM ALL LEADING MODEL SHOPS

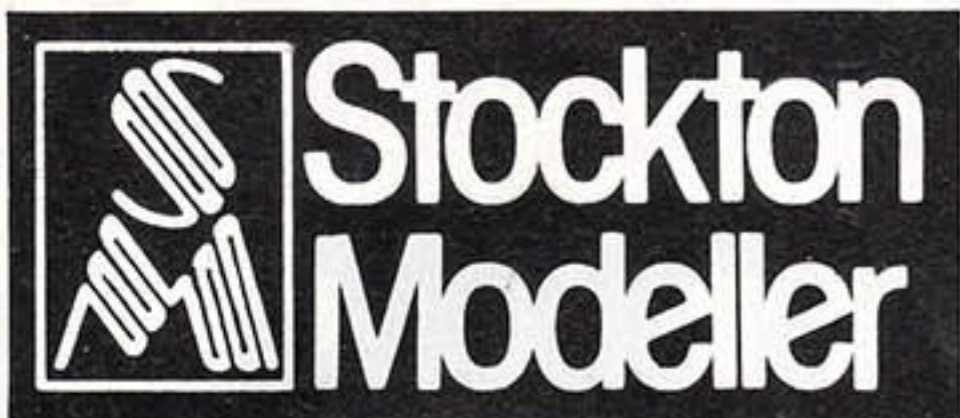

**17 HIGH STREET,  
STOCKTON, CLEVELAND TS18 1SP**  
**'Phone 0642 616680**  
**Open 6 days a week**  
**9.30-5.30**  
**STOCKTON MODELLER**  
**HOLDS THE ACES**

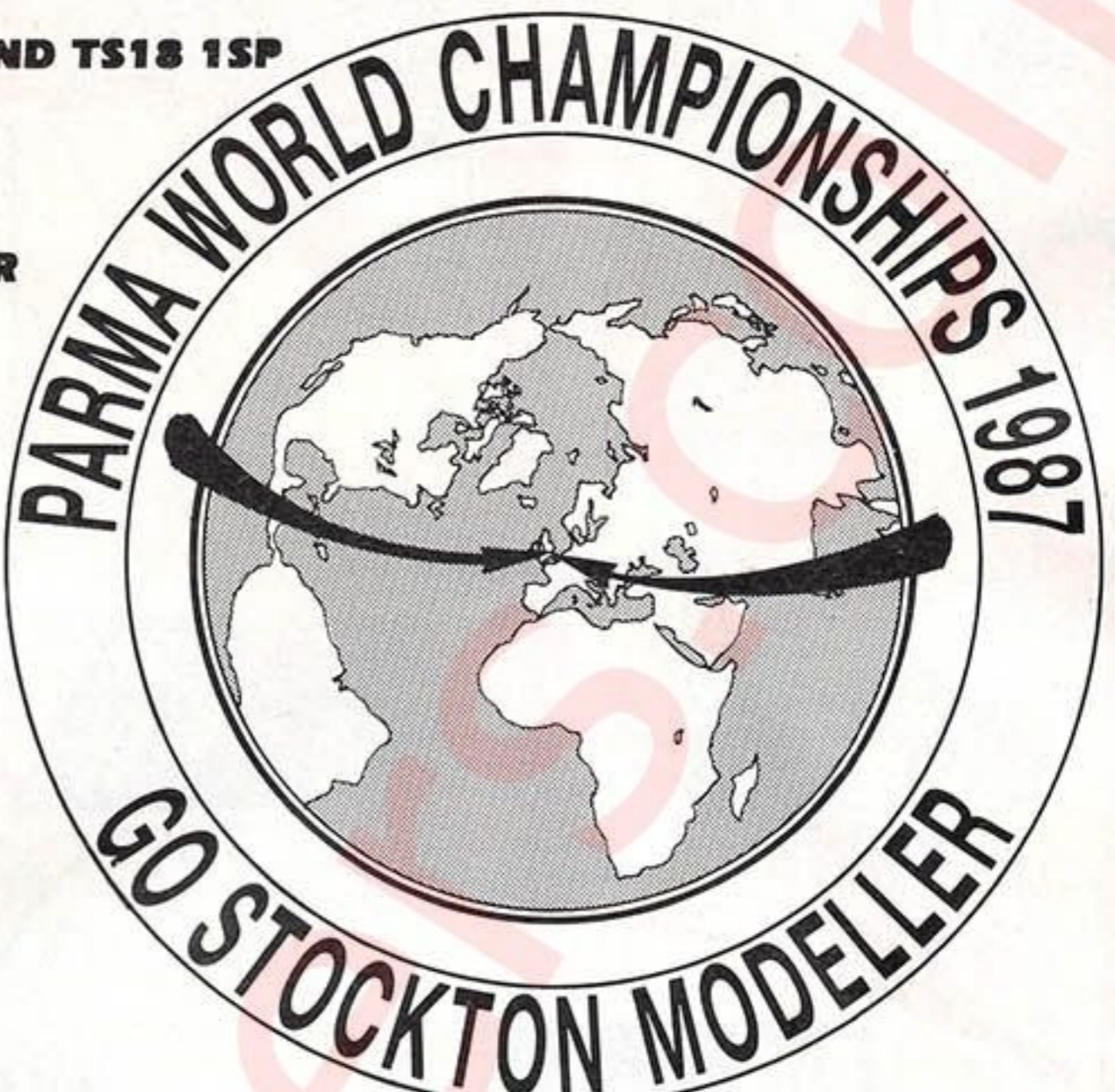

**DEALS**

	Kit	Deal
Mini Mustang 1 speed	£159.00	
Cat	£175.00	—
Falcon	£64.50	£124.50
Boomerang	£89.95	£149.95
Optima	£126.00	£187.49
Bigwig	£149.50	£217.50
Porsche 959	£136.50	£196.50
Ninja	£95.00	£155.00

**GENERAL ITEMS**

Digital volt meter (2yrs guarantee)	£32.95
Soldering Iron 240 volts 18w or 25w	£6.39
12 volts 18w	£6.88
12 volt Mini	£4.99

**CHARGERS/SPEED CONTROLLERS**

Firefly electronic speed controller	£42.50
Hercules auto fast charger	£24.99
MFA fast charger	£16.95
MFA transformer mains 12 volts	£15.95
MFA mains fast charger	£32.95
Firefly Thermal charger	£44.95
JME Thermal charger	£29.95

**MOTORS**

Demon 25T	£11.95
SRM Screamer 28T	£11.95
SRM Scorcher 27T	£11.95
Parma K Stock	£11.95
Kyosho Spirit (30T)	£11.95
MG Brown Dot — 27T plus zapping	£15.50
Parma Enduro Sprint, Super Sprint + turbo	£39.95
Reedy orange, silver gold	£40.00
Kyosho Le Mans 600	£12.95
Kyosho 480T	£25.00
480S	£25.00
240G	£39.95
240S	£25.00
360PT	£27.05
MG Magnum 18 double	£39.95
MG Magnum 17 quad	£39.95
MG Magnum 15 quad 2WD v.hot	£39.95
Motor Containers, keeps unused motors clean	35p
Foam Motor Covers	£1.25 or £1.95
Parma Commutators	£17.90

**TRINITY MODIFIED MOTORS**

RC 2002 Custom Modular Sprint	£40.00
RC 2003 Milder Arm. Enduro	£40.00
RC 2004 Pure Gold 2WD	£40.00
RC 2006 Turbo Blaster	£25.60

**LEXAN BODIES**

Parma range	from £9.95
TMS range	from £9.95
Jackal Lightweight+ Standard	£7.50

**MOTORISED MINI KITS**

Hornet, Fox, Hotshot, Boomerang	£4.99
Mercedes Benz, Unimog and Wild Willy's	£4.99
Ford Ranger Chevy Pick-up	
Toyota Pick-up + Range Rover	£4.50
These kits need 2 batteries	46p
1986 1/20 Honda Williams F.1 now available (not motorised)	£7.99

**SERVO**

Futaba S131 SH	£45.00
Futaba S132H Mini	£31.50
Futaba S133H Mini Micro	£37.00
Futaba S134 High Torque	£40.50
Futaba S138 Car Micro	£16.65
Futaba S135S Mini Micro (coreless)	£39.99

	Kit	Deal
Striker	£57.95	£117.95
Hornet	£59.99	£135.55
Grasshopper	£49.99	£126.00
Mardave Meteor	£59.95	£119.95
NEW Mini-Stock	£39.95	
Salute	£178.95	£256.45
Ultima	£94.99	£134.99

**ROCKY SPARES**

RK01 Bumper	£2.50
RK02 Wheel Set	£3.95
RK03 Diff gear set	£11.95
RK04 Front g/box	£3.50
RK05 Plastic parts	£6.50
RK06 Suspension Set	£3.95
RK10 Hub Set	£3.95
RK11 Ball Link Set	£8.75
RK12 Rear g/box set	£11.95
RK13 Gear Set	£8.95
RK19 Chain	£5.50
RK21 Drive joint set	£2.95
RK22 Front Wheel axles	£4.50
RK23 Rear Wheel axles	£4.50
RK25 G/box gear carrier shaft set	£6.95
RK26 Rear Damper Stay	£2.95
RK27 Screw Set	£6.95
RK28 Servo Saver Set	£1.95
RX29 Decal	£2.50

**BATTERIES**

Yellow Sticks	£18.50
Red Sticks Std/matched	£19.99, £24.95
MIH Pushed SCR's	£32.99

**BATTERY CONNECTORS**

7.2v Tamiya battery/charger ends	75p
6v Tamiya battery/charger ends	75p
Lightweight high current connectors with red and black heat-shrink	£1.25
Capacitors	pr 50p

**HEAT-SHRINK**

1/16" + 1/8" black each 60p; Sticks (clear) 70p; Stick battery packs (blue) 70p; Speed Controllers 70p; 1/4" 2 red + 2 black 4" lengths 65p
---

**GENERAL**

Parma polycarbonate paint, jar	£2.25
Thinners, jar	£2.95
Tamiya polycarbonate paint	£1.80
Superglue standard 20gm £2.55, Porous 20gm £2.55, Standard 50gm £4.95	

**BOOMERANG SPARES**

TMS Kydex bumper	£3.95
B parts and bumper	£4.10
C parts	£3.10
E parts	£1.70
R parts	£2.75
Chassis	£3.30
Front suspension uprate kit	£11.99
Drive Shafts	each £3.85
Body wing Switch cover	£10.50

**OPTIMA SPARES**

Ali Front Support	£3.95
OT 2 Chain	£4.95
OT 3 Wheel Sets	£4.95
OT 4 King Pins	£2.45
OT 5 Joint (drive cup)	£2.35
OT 6 Drive Shafts (2)	£5.00
OT13 Suspension Arm Set	£2.75
OT15 Bumper	£2.12
OT16 Knuckle Arms	£3.90
OT17 Front Shaft	£3.50
OT18 Rear Shaft	£3.50
OT21 Screw Nut & Wrench Set	£7.45
TMS Motor Guard	£4.75
OT27 Sprocket Gear Set	£5.95

OT28 Diff Gear Set	£5.95
OT30 Tyres x 2	£7.00
OT42 Servo Saver Set	£2.75
OT43 Rear Shocker Set	£11.75
OT45 Rear Hub	£1.55
OT47 Front Hub Set	£1.95
OT49 Gear Cover	£1.95
SC40 Motor Cover	£2.05
AB30 Front Shockers	£9.50

**BALLRACES**

Tamiya ballraces (large)	ea. £1.40
Tamiya ballraces (small)	ea £1.70
Optima Ballraces 5mm x 10mm	£1.80
Optima Ballraces 4mm x 8mm	£1.80
Ninja ball races (large)	ea. £2.10
Ninja ball races (small)	ea. £2.00

**HOT SHOT SPARES**

Front wishbones F parts	£2.80
Rear wishbones R parts	£2.75
Suspension uprights D parts	£3.75
E parts	£2.80
Gearbox casings	£6.90
Wheel axles (silver) SA9	ea £3.30
Wheel axles (black) SA8	ea £3.30
Drive shafts front and rear	ea £4.10
Wheel centres gold	£6.99
8mm ball connectors	pr 99p
5mm ball connectors BF2 (long)	pr 70p
Diff crown wheels	pr £1.40
Diff. planet gears	set 3 £1.50
Plastic gears	set £3.99
Mechanism box chassis	£3.35
Lexan shell	£8.80
Supershot shock conversion set	£16.50
Supershot underguard	£2.60
Supershot drive shafts	each £3.85

**PORSCHE 959 SPARES**

Pinspike wheels & tyres	£7.99
Body Set	£24.99
Speed controller	£11.99
Wheels & tyres (2)	£6.99
Slick tyres/wheels	£5.99
Gear Set (metal)	£4.99
Gear Set (plastic)	£4.50
A parts	£5.30
B parts	£2.99
E parts	£2.60
F parts	£2.10
D parts	£5.75
Drive shafts	each £2.20
Rear Coil Spring	each 40p

**BIG WIG SPARES**

Body parts	£16.99
Speed controller	£10.50
A parts	£4.15
F parts	£2.99
C parts	£3.99

Chassis	£3.40
Sub chassis	99p
Steering boot (2 pcs)	£2.10
B parts & bumper	£4.60
Pressed parts bag	£2.50

**TYRES**

Fox/Wild One fronts	pr. £4.20
Hot Shot/Wild One block fronts	£4.50
Hot Shot/Wild One block rears	£4.75
Hot Shot/Wild One spike fronts	£4.20
Hot Shot/Wild One spike rears	£4.70
Mardave 5x4, 3x2 rears	pr £3.80
Mardave new wonder fronts	pr £3.80

**RADIOS**

Acoms Technisport	£69.99
Futaba 2LGX	£109.99
Futaba Magnum junior	£89.95
Futaba 3EGX Gold Combo	£162.50

**FALCON SPARES**

A parts	£3.15
B parts	£3.15
C parts	£4.20
D parts	£2.90
R parts	£3.15
F parts	£2.30
Chassis	£2.90
Gearbag	£2.30
Stickers	£1.50
Body parts	£14.99
Front wheel & tyre set	£5.99
Rear wheel & tyre set	£6.99
Plastic drive shaft set	£5.20
Spring fronts & rear	pr 65p

**STOP PRESS**  
**World Championship Results**  
2WD final Ultimas 1st, 2nd & 3rd  
4WD final Cats 1st, 3rd & 4th  
Both these kits can be purchased from Stockton Modeller with full spares back up

**DIARY NOTE**  
Stockton Modeller sponsored Aces Trophy National Open Indoor Meeting at Stokesley School (off A19) 8th November 1987. Send SAE to shop for entry forms

POSTAGE: Under £10 — 50p, over £10 — 75p.  
Deals — £3.25 inc. insurance. Cars + radios £2.50. Allow 7 days for clearance of cheques. All enquiries SAE please. Please note all prices are correct at time of going to press and we retain the right to alter prices to those at the despatch date.

# G.K. MODELS PUTTING YOU RIGHT

**G.K. MODELS**



1:18 scale models  
from £11.25

1:24 scale models  
from £3.10

post & packing 75p  
Orders over £20  
post & packing free

**STOP PRESS!**

We now stock Die-Cast Models

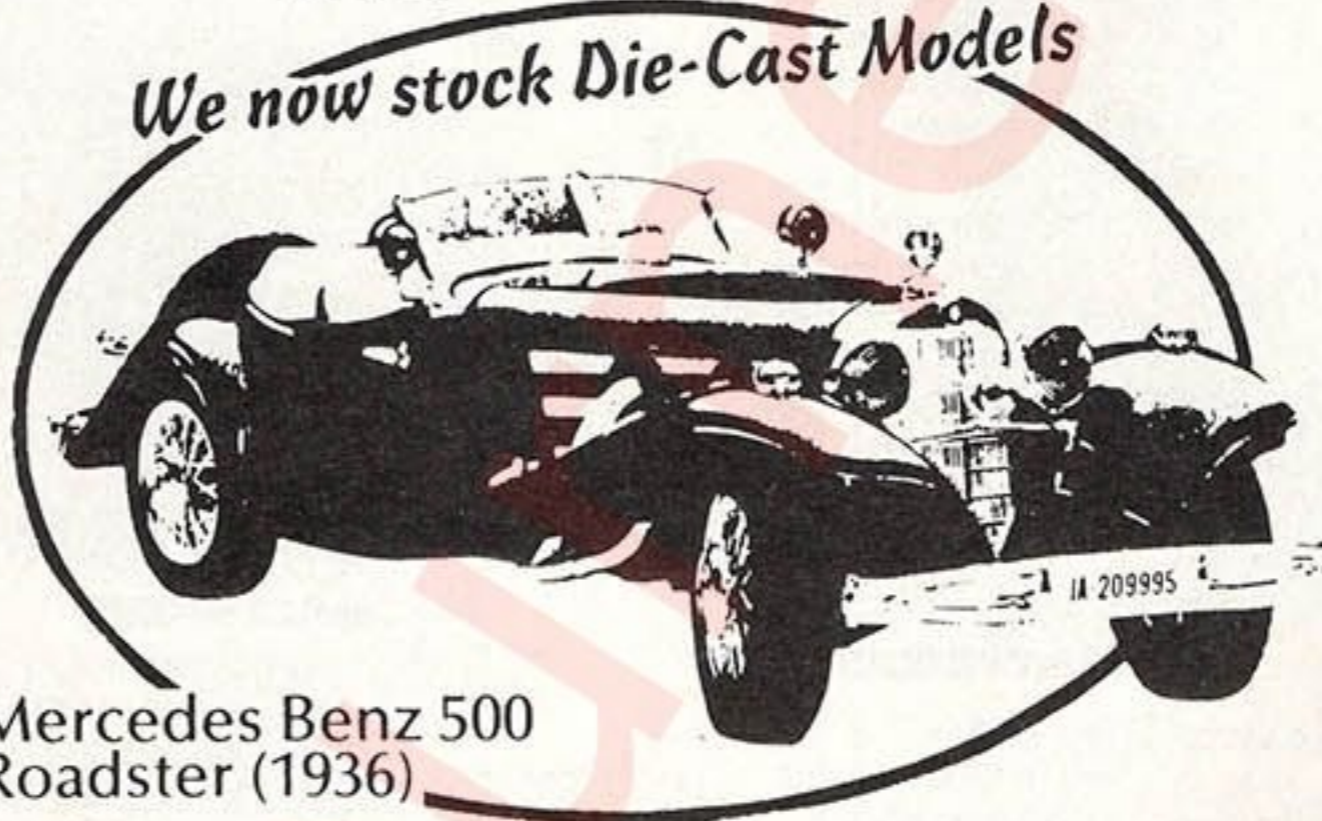

Mercedes Benz 500 Roadster (1936)



1:16 scale models  
from £12.75

1:25 scale models  
from £4.99

Send large S.A.E. for Free List of over 200 cars available

**Ninja**



- GOLDEN EAGLE ..... £51.95
- HUNTER ..... £54.95
- BIG BEAR ..... £54.95
- SAMURAI (4WD) ..... £83.95

KIT PRICE £89.95 (p&p £2.25)  
DEAL PRICE £156.75 (p&p £3.50)  
BEARING SET £35.48 post free



☆ Special Offers ☆

- HORNET ..... £47.20
- STRIKER ..... £52.15
- FALCON ..... £57.60
- BLACKFOOT ..... £70.80
- MONSTER BEETLE ..... £78.25
- BOOMERANG ..... £80.75
- HOTSHOT 2 ..... £106.95
- PORSCHE 959 ..... £122.00
- BIGWIG ..... £133.60



£80.75

BOOMERANG



£133.60

BIGWIG



£106.95

HOTSHOT

**NEW**

**G.K. MODELS, 390 HOLDENHURST ROAD,**

# DU ON THE TRACK

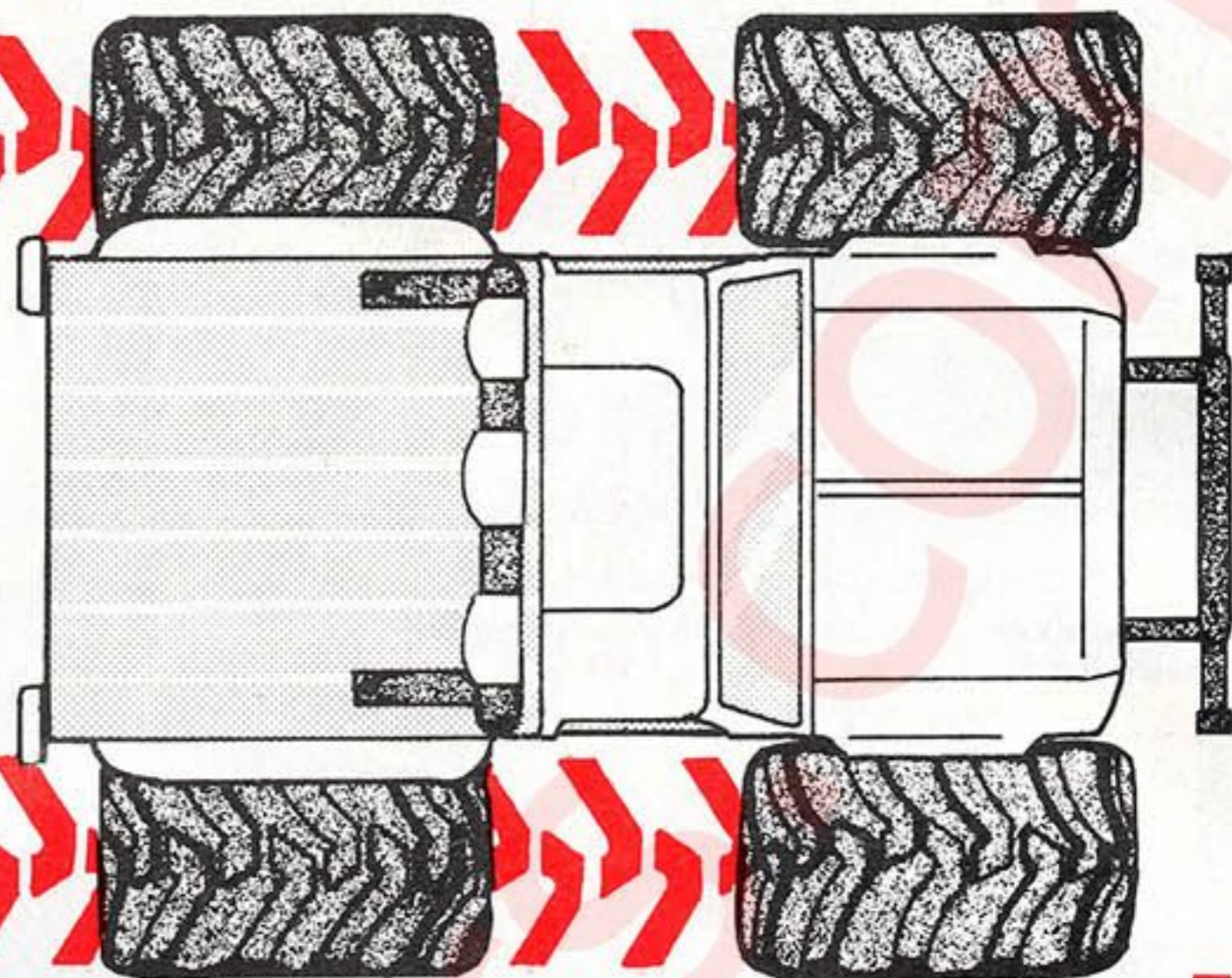

The 2 or 3 months preceding Christmas are our busiest. Please place your orders for any items required by Christmas by 20th November at the latest. Please note that we shall be closed from 24th December-6th January inclusive.

Our 1987 Catalogue is now being produced, the main difference will be it will only feature one car – Your car! plus all the Special parts, Competition parts, Extras and Ancillaries generally available including Chargers & Batteries.

The price will be £2.95 plus £1 p/p (please state car)

Our Spares were on Computer Nine Years ago and we have supplied many customers all over the World, many with spares they have been unable to obtain through their normal suppliers. We try and maintain a Full Spares Backup where possible and strive to carry All Our Catalogued items in stock at All Times.

Most Customers will already know about our Extra Value Package Deals (In many cases containing More Items than many other advertised package deals) including Our Own 40 page R/C Guide for the First Time User (Another First, we believe, from G.K. Models). So helpful is Our Guide that we have had customers who have been unfortunate enough to purchase a lesser value package elsewhere requesting copies, these are now available at £1.95 +.75p p&p

You want parts?  
We've got the lot



BACK UP WHERE YOU NEED IT

**KYOSHO**  
THE FINEST RADIO CONTROL MODELS

DEALS on Application

## NEW OPTIMA TURBO (4WD) P.O.A.

ULTIMA .....	£94.95
OPTIMA.....	£119.95
SALUTE .....	£167.95

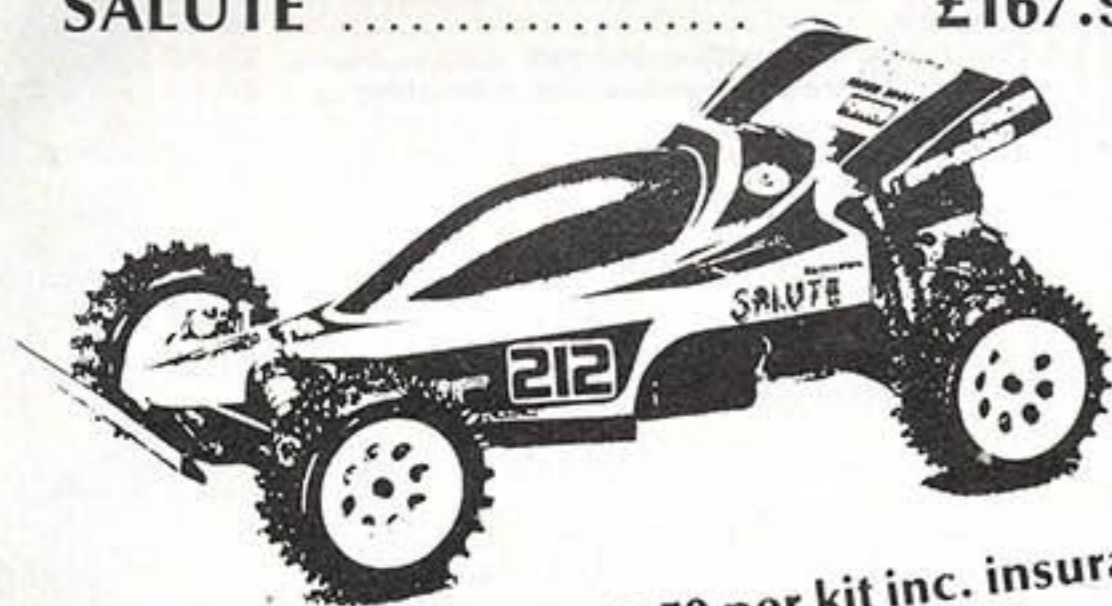

P&P £2.50 per kit inc. insurance



Places exported to:

- |           |                  |
|-----------|------------------|
| Ascension | Canada           |
| Australia | Cyprus           |
| Austria   | Denmark          |
| Bahrain   | Falkland Islands |
| Barbados  | Finland          |
| Belgium   | France           |
| Brunei    | Germany          |

BOURNEMOUTH

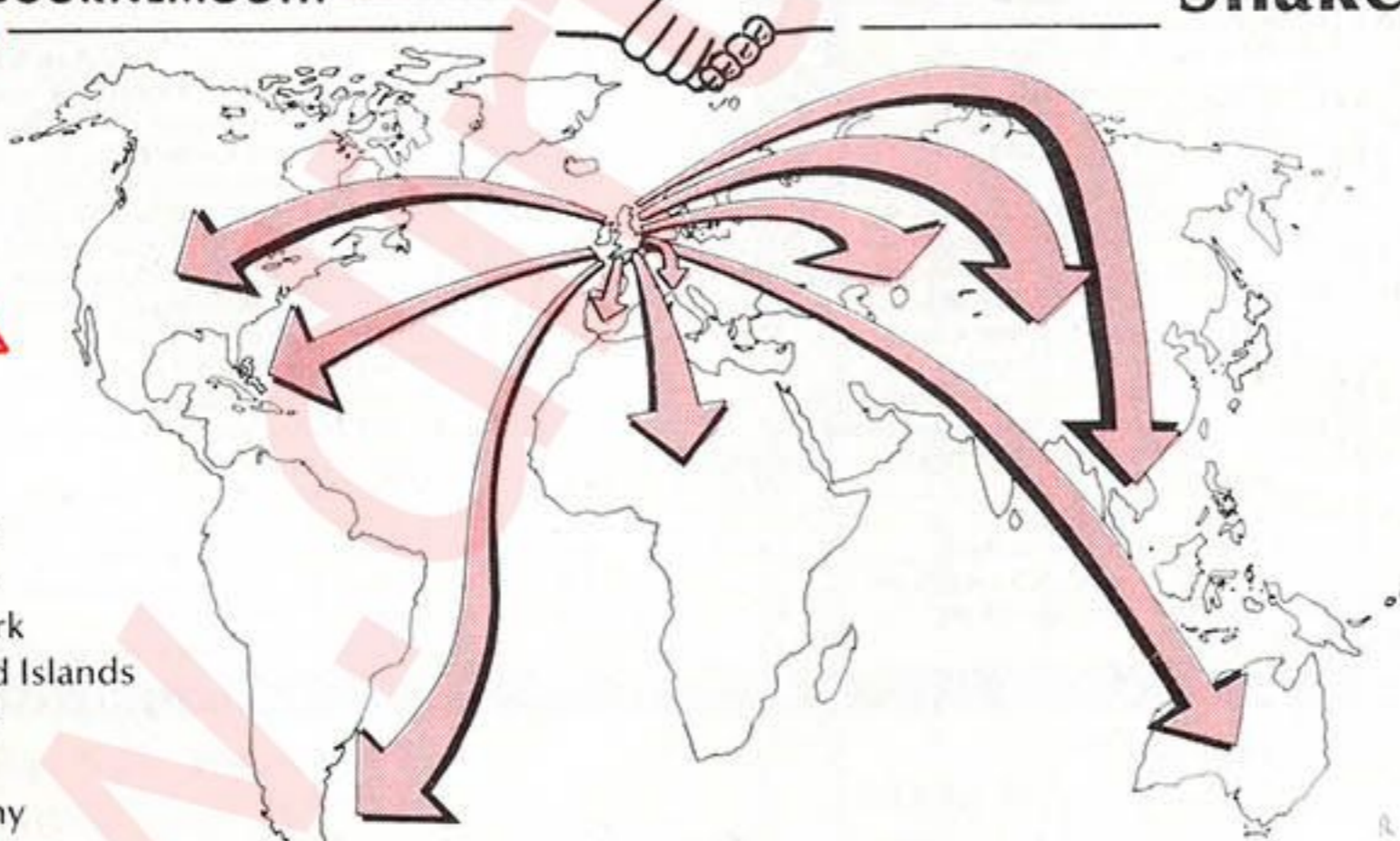

## Shakes Hands with the WORLD

- |                     |                  |
|---------------------|------------------|
| Guernsey            | Papua New Guinea |
| Hong Kong           | Portugal         |
| Iceland             | Qatar            |
| Italy               | Saudi Arabia     |
| Jersey              | Singapore        |
| Kenya               | Spain            |
| Korea               | Sweden           |
| Kuwait              | Switzerland      |
| New Zealand         | Thailand         |
| Norway              | USA              |
| Oman (Sultanate of) | Zambia           |

We try to despatch all orders the same day that we receive them, but occasionally heavy demand on an item may mean that we cannot despatch the same day ... therefore we say :- Should you not wish to wait, please enclose a stamped addressed envelope and we will refund your order and money. Many of you will already know how fairly we deal with our customers through previous advertising. We do NOT hold on to ANY orders. It is not in our interest to do so. However where a customer does not send a stamped addressed envelope and we do not have the item in stock if there is going to be more than a 7 day delay we will inform them. Orders are dealt with as follows:- Visa or Access/Cash Orders/Bank Draft/Postal Orders – Same Day Despatch on all Stock Items. Cheque – Please allow approx. 7 days despatch. Orders over £20 will be post & packing free ... except where otherwise stated. Orders under £20 ... please add 75p post & packing to your order. Complaints:- should any arise, will be dealt with the same dedication as when we received your order. Price Increases:- We try to maintain our advertised prices as long as possible, but because adverts have to be in some months before a magazine appears on the bookshelf, it is not always possible and so we reserve the right to charge the price as at despatch date. Replies cannot be dealt with without a stamped addressed envelope. Overseas enquiries please include an International Reply Coupon. We value your custom ... the customer is important to us, we cannot survive without you so we try harder to please.

BOURNEMOUTH, DORSET BH8 8BL. ☎: (0202) 34007

**202 WERRINGTON ROAD  
BUCKNALL  
STOKE ON TRENT  
ST2 9AW  
Tel: (0782)  
281810**



SPARES AVAILABLE SPARES AVAILABLE SPARES AVAILABLE SPARES AVAILABLE SPARES AVAILABLE SPARES AVAILABLE

**MARDAVE'S NEW FAST MOVING STAR  
OF THE OFF ROAD CIRCUITS**



*Meteor*

This easy to build and fully competitive car features two wheel drive for minimum power loss and maximum speed, limited slip differential unit, adjustable oil filled dampers on each wheel, rugged double wishbone suspension with adjustable top links for camber changes, high grip spiked rubber tyres and unbreakable HE 30 dural chassis. Its basic light weight (3lb 2oz approx) makes expensive lightening accessories unnecessary and, as usual from Mardave, spares are guaranteed available, low priced and you do not have to buy half a car when you only need one screw.

STANDARD KIT (including speed controller and Mabuchi 540 motor) SRP £59.95  
 COMPETITION KIT (less motor and speed controller but with 4 extra ballraces in rear stub axles) £57.00  
 6 CELL BATTERY PACK WITH CONNECTOR £14.95  
 FAST CHARGE LEAD £5.95

**MARDAVE MINI  
STOCK**



**Kit ..... £39.00  
Deal ..... £80.00**

- K1 Chassis plate, fibreglass ..... £2.00
- K2 Front axle beam with steering arms and king pins ..... £0.95
- K3 King Pin ..... £0.07
- K4 Front stub axle with nyloc nut ..... £0.35
- K5 Steering bellcrank/servo saver, complete ..... £0.95
- K6 Track rod ..... £0.18
- K7 Rear axle bearing blocks without bearings, pr ..... £0.95
- K8 Nylon bearings, pair ..... £0.35
- K9 Front wheel ..... £0.35
- K10 Rear wheel, with grub screws ..... £0.80
- K11 Front tyre ..... £0.40
- K12 Rear tyre ..... £0.50
- K13 Rear axle, high tensile steel ..... £0.50
- K14 Pinion drive gear, 12 tooth steel with grub screws ..... £1.30
- K15 Battery pack, 4 cells re-chargeable with plug ..... £10.95
- K20 Speed controller, complete ..... £7.20
- K21 Speed controller, printed circuit board only ..... £1.30
- K22 Speed controller, plastic wiper disc ..... £0.32
- K23 Speed controller, wiper contact, copper ..... £0.25
- K25 Servo linkage rod with snap on ball connector ..... £0.25
- K26 Fast charge lead for 4 cell battery ..... £5.95
- K27 Front bumper ..... £0.35
- K28 Rear bumper ..... £0.35
- K30 Front bumper mounting bracket ..... £0.70
- K31 Rear bumper mounting bracket ..... £0.85
- K33 Bodyshell, white ABS plastic ..... £2.25
- K34 Windscreen mesh ..... £0.65
- K36 Swing keepers, pack of 4 ..... £0.35
- K37 1.5mm key (for motor pinion grub screw) ..... £0.16
- K38 2.0mm key (for rear wheel grub screws) ..... £0.16
- K39 Self tap screws, M3 x 9mm long, pack of 10 ..... £0.32
- K40 M3 Machine screw x 6mm long, pack of 10 ..... £0.32
- K41 M3 steel nuts, pack of 10 ..... £0.32
- K42 M3 Machine screw x 8mm long (Motor fixing screw) Pack of 10 ..... £0.32
- K43 M3 Nyloc nut (front wheel retainer) each ..... £0.08
- K45 Double sided adhesive tape, per strip ..... £0.20
- K46 Body fixing clip, pack of 4 ..... £0.40
- K47 Front body mounting pillar, plastic ..... £0.20
- K48 Rear body mounting stud, steel ..... £0.25
- K50 Aerial plate ..... £0.50
- K51 Aerial plate mounting pillar ..... £0.20

T1 Chassis ..... £3.50	T54 Diff. cap screw, washer and locking screw set ..... £0.40
T2 Front Bumper ..... £0.50	T55 2.5mm key ..... £0.16
T3 Battery holder moulding ..... £0.50	T56 1.5mm key ..... £0.16
T4 Rear Bumper mounting bracket ..... £0.50	T57 Diff ball race ..... £2.25
T5 Front body mounting pillar ..... £0.32	T58 Drive shaft ..... £1.00
T6 Aerial Plate ..... £0.50	T60 1st (large) intermediate gear ..... £0.80
T7 Rear Bumper ..... £0.80	T61 2nd (small) intermediate gear ..... £0.40
T11 Front Wheel ..... £0.80	T62 2nd int. gear pin ..... £0.16
T12 Rear Wheel ..... £0.95	T63 Motor pinion gear 12 teeth ..... £1.30
T13 Front tyre, 3 x 2 spikes ..... £1.60	T70 M3 x 16mm screw ..... £0.08
T14 Rear tyre, 5 x 4 spikes ..... £1.90	T71 M3 steel nut, pack of 10 ..... £0.32
T16 Servo saver bellcrank set ..... £1.30	T72 Self tap screw 9mm, pack of 10 ..... £0.32
T17 Outer track rod link ..... £0.25	T73 Self tap screw 12.5mm pack of 10 ..... £0.32
T18 Centre track rod link ..... £0.25	T74 Self tap screw 16mm pack of 10 ..... £0.32
T19 Large nylon ball joint with alum. ball, washer and nut ..... Pack of 4 £1.90	T75 Self tap screw 19mm pack of 10 ..... £0.32
T20 Large nylon ball joint with steel ball and self tap screw ..... Pack of 4 £1.90	T76 'E' clip, for 3mm shaft pack of 10 ..... £0.32
T21 Small nylon ball joint with steel ball and nut ..... Pack of 4 £0.80	T77 'E' clip, for 4mm shaft pack of 10 ..... £0.32
T23 Front suspension mounting bracket L.H. .... £0.50	T78 'E' clip, for 5mm shaft pack of 10 ..... £0.32
T24 Front suspension mounting bracket R.H. .... £0.50	T80 Front coil spring and oil filled damper unit (pair) ..... £4.00
T25 Front suspension wishbone ..... £0.50	T81 Rear coil spring and oil filled damper unit (pair) ..... £4.00
T26 Steering uprights, L & RH ..... Pair £0.50	T82 Front damper shaft ..... £0.50
T27 Steering L & RH ..... Pair £0.50	T83 Front coil spring ..... £0.32
T28 Front stub axle ..... £0.16	T84 Rear damper shaft ..... £0.50
T29 King pin ..... £0.08	T85 Rear coil spring ..... £0.32
T30 Inner hinge pin (42mm long) ..... £0.16	T86 'O' Ring (pack of 4) ..... £0.40
T31 Outer hinge pin (32mm long) ..... £0.16	T90 Bodyshell and wing ..... £3.20
T32 Front upper threaded link ..... £0.16	T91 Driver figure ..... £0.65
T33 Servo linkage ..... £0.16	T92 Body fixing clip (pack of 4) ..... £0.40
T40 Gearbox mouldings (pair) ..... £1.30	T94 Speed controller complete ..... £7.20
T41 Gearbox cover mouldings ..... £0.50	T95 Voltage dropper diodes for Rx power ..... £1.00
T42 Rear suspension wishbone ..... £0.50	T96 Speed control wiper disc ..... £0.32
T43 Rear suspension upright ..... £0.50	T97 Speed control wiper contact ..... £0.25
T44 Rear stub axle ..... £1.00	T98 Printed circuit board ..... £1.30
T45 Bearing, rear stub axle ..... £0.40	T99 Double sided adhesive tape ..... £0.20
T46 Drive pin, rear wheel ..... £0.16	T101 RS 540 motor with suppressor ..... £4.95
T47 Rear upper threaded link ..... £0.16	T103 6 cell rechargeable battery pack with connector ..... £13.95
T48 Rear inner hinge pin ..... £0.16	T105 Fast charge lead ..... £5.95
T49 Rear outer hinge pin ..... £0.16	T107 Connector for battery ..... £0.65
T50 Differential unit, complete ..... £6.50	T108 Connector for charge lead ..... £0.65
T51 Diff. gear wheel ..... £0.40	T110 Assembly instructions ..... £0.50
T52 Set of 3.5mm dia. steel balls ..... £0.80	
T53 Set of 1.5mm dia. steel balls ..... £0.80	

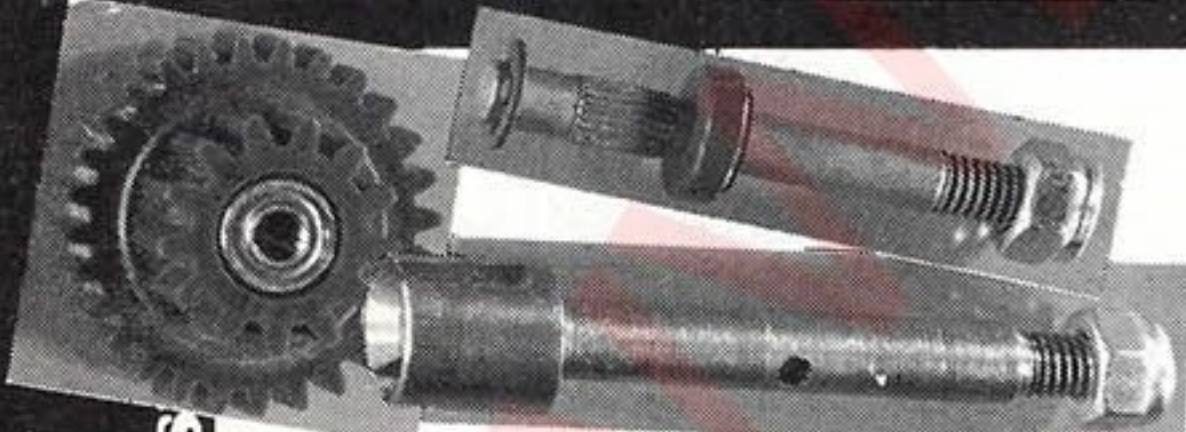

**Replacement Front Stub Axle (T28) and Rear Stub Axle (T44). For set of 4 Shafts ..... £5.50**  
 Also Ballraced Intermediate Gear ..... £5.00  
 Full Width Bumper ..... £1.50

**TEAM LOSI**  
 FINE PITCH SPUR GEARS  
 96T 100T 108T ..... £3.75  
 STANDARD MOTOR 6060  
 MODIFIED MOTOR 6040, 6046, 6054 6056  
 FINE PITCH MOTOR PINIONS  
 19T 20T 21T 22T 23T 24T 25T 26T  
 27T 28T 29T 30T 31T 32T 33T 34T  
 35T 36T ..... £4.25

AYK Bobcat ..... £50.00	Kits only	Deals
Tamiya Hornet ..... £49.00		P.O.A.
Tamiya Blackfoot ..... £76.00		P.O.A.
Tamiya Big Wig ..... £142.00		P.O.A.

Tamiya Boomerang ..... £86.00	P.O.A.
Tamiya Falcon ..... £61.00	P.O.A.
Tamiya Grasshopper ..... £43.00	P.O.A.
Tamiya Beetle ..... £85.00	P.O.A.
Tamiya Striker ..... £56.00	P.O.A.
Tamiya Porsche 959 ..... £130.00	P.O.A.
Kyosho Rocky ..... £95.00	£147.00
Kyosho Optima ..... £110.00	£167.00
Optima Turbo ..... £165.00	POA
Salute ..... £150.00	POA
Ultima ..... £92.00	£147.00
Cosmo ..... £68.00	£125.00
Tamtech ..... —	£135.00

AVAILABLE SPARES

SPARES AVAILABLE SPARES AVAILABLE SPARES AVAILABLE SPARES AVAILABLE SPARES AVAILABLE SPARES AVAILABLE



**THE CAT** £175.00  
**NEW**  
**'XL CONVERSION KIT'**

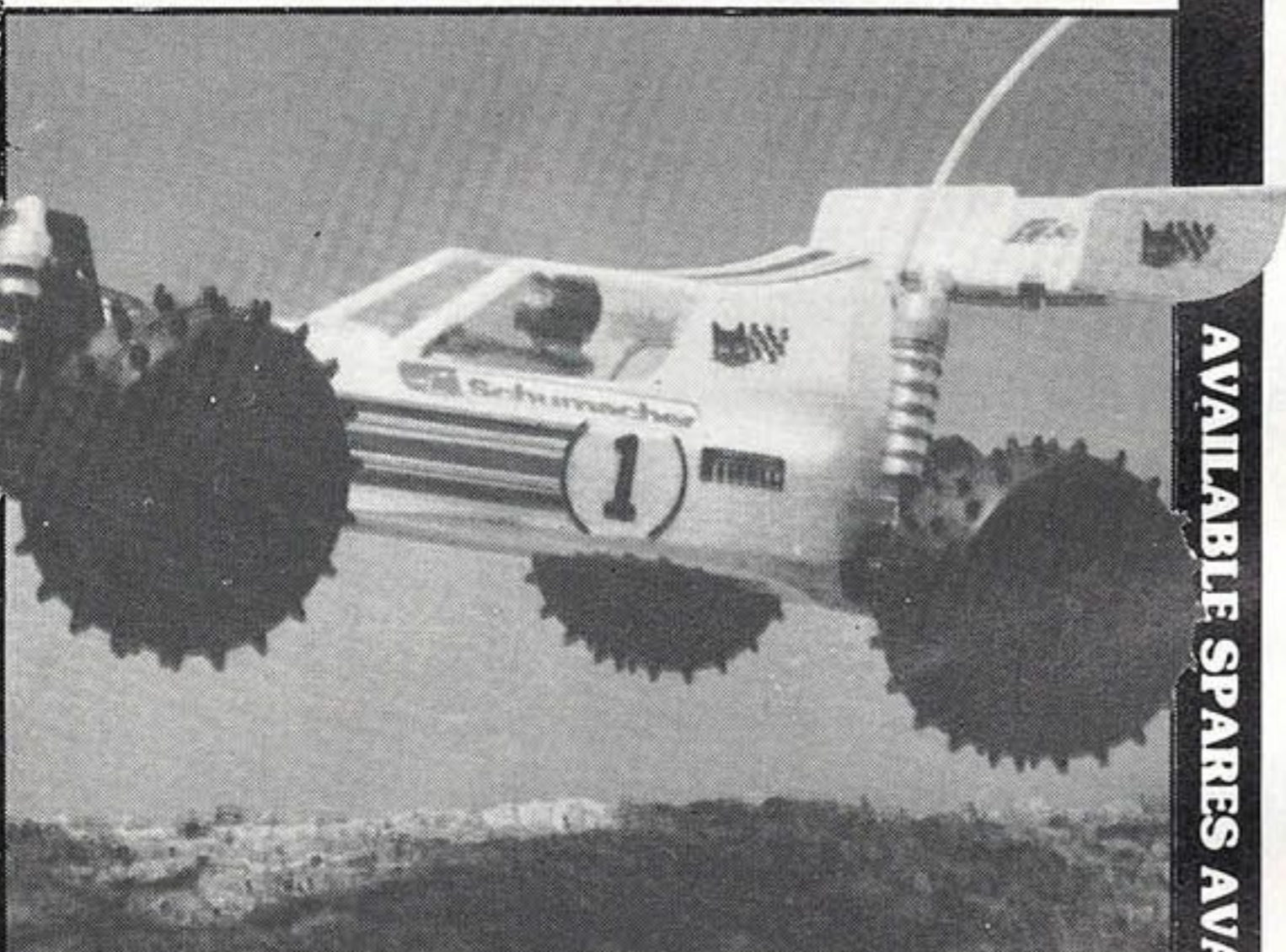

The 'XL' increases wheelbase app. 25mm. This gives even greater improved stability, better launch and landing approaches.

Kit includes:- XL 2pce Chassis, Body and Undertray, XL Belt Available as Part No. 1642

**NEW ITEMS:**

T637 Shock Pistons	£1.00
T638 Steering Pivot Set	£2.50
T639 Thrust Race Conv.	£3.99
T640 1-Way Drive Shafts	pr. £17.00

**TYRES**

Narrow Fronts, Hard or Soft Compounds ..... pr. £5.80  
2 x 2 Spikes also fit Tamiya!

**CAT SPARES**

	Qty.	
A188 Tension Band	5	86p
A510 B.R. 1/8 x 1/4 NF	2	£4.28
A530 B.R. 8-16-5 NF	4	£4.99
A532 B.R. 8-12 F	2	£5.99
A533 B.R. 8-16-5 NF SS	4	£4.99
A541 One WEay Clutch	2	£5.00
C058 Battery Clamps	2	£1.50
T006 Pivot Bkt. pr.	2	£2.31
T012 R Wheels	2	£2.52
T013 F Wheels	2	£2.52
T045 Pivot Ball	4	£1.50
T052 F Hub Carrier	2	£5.99
T055 F Transmission Housing	2	£1.62
T058 Arm Front Suspension	2	86p
T062 Piston Rod 16mm	2	£1.47
T063 Piston Rod 32mm	2	£1.47
T070 Rear Trans. House Inner	1	£2.41
T071 Rear Trans. House Outer	1	£1.67
T074 Chassis Lower	1	£5.10
T075 Chassis Upper	1	£3.55
T084 Rear Axle	1	£1.10
T085 Diff. Shaft	1	£1.10
T086 Front Axle	1	£3.07
T102 Rod End Ball	4	£1.50
T103 Bumper	1	£2.10
T104 Rear Hub Carrier	2	£5.99
T105 F/G Rear Susp. Bkt.	1	£1.10
T106 F/G Rear Shock Bkt.	1	£1.10
T116 F/G Track Rod	1	86p
T123 Gear 55TL	1	£1.16
T124 Gear 58TL	1	£1.16
T125 Gear 60TL	1	£1.16
T128 Belt Long	1	£3.35
T129 Belt Short	1	£4.55
T132 Front Springs	2	83p
T133 Rear Springs	2	83p
T508 Body Moulding Sheet	1	£7.57
T509 Undertray Sheet	1	£7.62
Tyres Soft	4	£11.90
Tyres Hard	4	£11.90
T511 Shock Set	4	£22.77
T513 Screw Bag	4	£9.65
T514 Ball Race Set	1	£25.94
T516 Joints Bag	1	£8.28
T517 Bearing House Moulding	1	£1.97
T518 Bkt Moulding	1	£1.93
T526 Front Diff	1	£16.75
T612 Hub Moulding	1	£2.66
T613 Spr. Stops & Spacers	1	£1.86
T614 Shock Seals	1	£7.69
T616 Wishbone Set 4	1	£2.50
T617 Pulley Mouldings 50-51T	1	£2.35
T618 Pulley Mouldings 21T & Cage	1	£1.86
T620 Screw Bag A	1	£2.14
T621 Screw Bag B	1	£3.75
T622 Screw Bag C	1	£3.79
T623 All Side Plates	1	£4.59
T624 Rear Susp. Pivots	1	£2.00
T625 Rear Anti Roll Bar	1	86p
T626 Front Anti Roll Bar	1	£1.31
T627 Servo Saver	1	£2.25
T628 Front Shocks Parts	1	£5.69
T629 Rear Shocks Parts	1	£5.99
T630 Drive Shafts	1	£3.04
T631 U/J Bag	1	£5.52
T632 Diff/Int. Repair Kit	1	£2.86
T633 Front Shocks Comp.	1	£15.94
T634 Rear Shocks Comp.	1	£16.39
T635 Front Diff. Repair Kit	1	£1.38
A534 Bearing Seals	1	£1.35

Schumacher/Mike Reedy Modified Motors	
Red Dot, Silver Dot, Gold Dot	£40.00
Schumacher Modified 14T Single	£25.00
New PC3 Ammeter Peal Charger	£44.50
Nodis Fine Pitch Gear for Cat	

AVAILABLE SPARES AVAILABLE SPARES AVAILABLE SPARES AVAILABLE SPARES AVAILABLE SPARES AVAILABLE SPARES AVAILABLE

# ONE-O-ONE MODELS



**PIGGLES POST FREE SPECIALS!**

**NEW CHALLENGER 2PX** 2 channel steerwheel radio. Includes all the features normally only found in more expensive radios. Complete with 2 servos, receiver and battery box.  
PGP **49.95**

**SPECIAL AIRBRUSH OFFER.** This is the ideal airbrush for the R/C modeller. Almost an exact copy of a Badger 350 (retails at over £40). Kit comprises airbrush, hose, regulator, can of air, and two jars.  
Plus 4 jars of airbrush enamel value £2.20 free  
PGP **21.95**

**FREE FREE FREE** **SPECIAL OFFER THIS MONTH ONLY.** Purchase any item from this ad and receive our rate trim kit absolutely free. (Rate trim kit excluded from this offer.)

**NEW NEW NEW** **SLEC HOVERBUG.** Uses 2 channel radio and nicads and motor from your buggy. Lightweight ABS construction gives the Hoverbug Hovercraft superb performance. It's a lot of fun for a little money  
PGP **28.95**

**FUTABA MINI RECEIVER.** Save space and weight with this very small receiver. Available only with new type (not old 1.3ms) plugs.  
P.G.P. **27.95**

**LCD DIGITAL VOLT METER.** A complete ready built unit to fit into your own charger. Reads up to 20 volts. The only way to accurately monitor your cells charge.  
PGP **22.95**

**KYOSHO SPIRIT 600** The latest from Kyosho. The best all round stock motor on the market. Improve your cars performance for only  
PGP **11.95**

**INTRONICS FIREFLY BUGGY SPEED CONTROLLER.** Superb quality electronic controller. Very reliable and well made. Fits most buggys, with built in R/X battery eliminator.  
P.G.P. **39.95**

**RATE TRIM KIT** - An absolute must for any serious driver, easily fitted to almost any transmitter. Allows complete adjustment of steering travel from your transmitter. No mechanical adjustments req. You will wonder how you ever got on without one. Supplied with full fitting instructions.  
PGP **3.95**

**FOR A PIGGIN GOOD DEAL!**

- ★ Easy Free Parking right outside
- ★ Open 6 days a week 10am - 6pm
- ★ Late night Friday until 8pm
- ★ 5 mins from M2 motorway Junction 3, but we are not in the town centre. Please phone for directions if unsure of our location.
- ★ Sorry but we are a true specialist model shop (R/C only) and therefore do not stock the usual items, i.e. umbrellas, hoola hoops, toys, trains, tennis rackets, plastic kits, Xmas cards, vegetables! Games, fishing tackle, sweets, kites etc, just R/C models...

p&p extra on all items. \*PGP - Pigglin Good Price  
All items subject to availability

**12 THE LINKS, CHATHAM, KENT ME8 9UE**  
Tel. Medway (0634) 826410

AVAILABLE SPARES AVAILABLE SPARES AVAILABLE SPARES AVAILABLE SPARES AVAILABLE SPARES AVAILABLE

# TEAM ASSOCIATED RC10

# ROAR 1:10 NATIONAL CHAMPION ORRCA NATIONAL CHAMPION



### THE TEAM DOES IT IN THE DIRT.

Race the car that bear the imports in the toughest kind of off-road competition.

The All-American Associated RC10 took home the gold in both the ROAR and ORRCA National Championships.

Our RC10 turned back the foreign car invasion with the same racecar technology that has kept Team Associated on top of the RC car racing world for over 15 years.

### A RACE CAR, NOT A TOY.

Sure, you've heard that before.

But Team Associated designs and engineers only model RACE cars.

The new RC10 features fully adjustable, four wheel independent suspension, an aluminum alloy monocoque tub and race-proven hardware throughout.

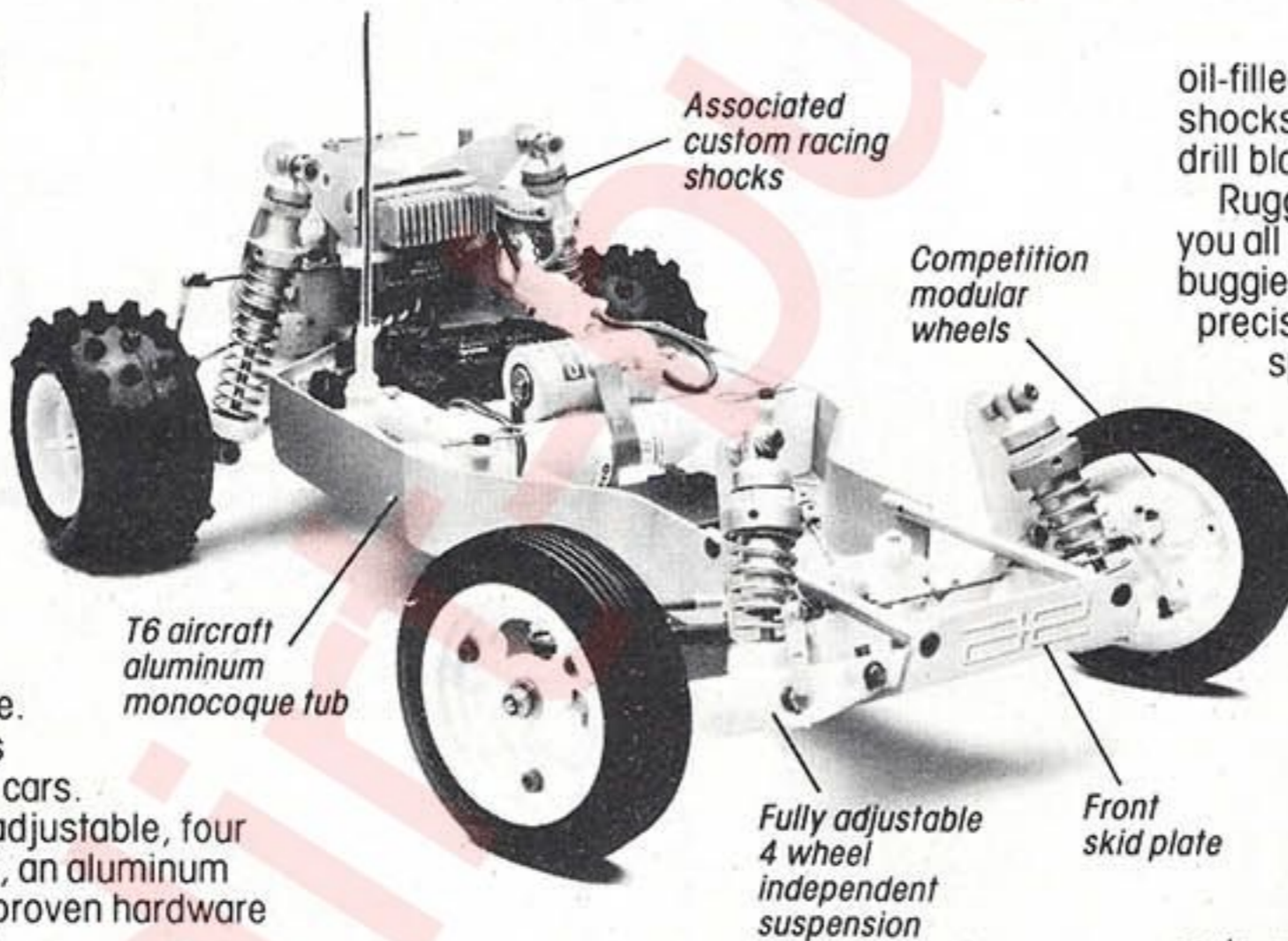

oil-filled racing shocks. These custom shocks use machined alloy cylinders and drill blank shafts for silky smooth action.

Rugged, yet light, the suspension gives you all the adjustability of full size, full race buggies. The A-arm/Ball joint design allows precise camber, caster, ride height and spring rate tuning. Even anti-roll bars and a VariLok dif are included.

Exceptional ground clearance and low center of gravity also contribute to the superb balance and performance of the RC10 over all types of terrain.

### GET THE JUMP ON THE COMPETITION.

Go RC off-road racing with the leaders. The National Champion RC10 is available now and legal for ROAR and ORRCA nationally sanctioned competition.

Complete RC10 kits, replacement parts and spares are readily available through model car racing's most extensive dealer network.

Take the challenge and build yourself a winner. Team Associated's RC10.

And the RC10 doesn't need expensive accessories and modifications to handle the roughest tracks. The strength and durability is standard equipment.

### RACE-WINNING ENGINEERING.

For maximum traction the RC10 suspension is damped by long throw,

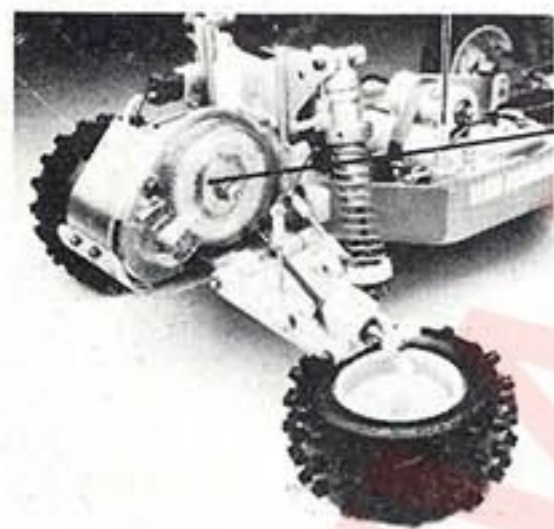

Sealed gearbox  
VariLok  
differential

Full race rear suspension includes bulletproof half shaft and u-joints with tapered and keyed modular wheels. Quick release knock off design for fast pit work and tuning.



Model cars for Real racers.

Associated Electrics  
3585 Cadillac Avenue  
Costa Mesa, CA 92626  
Tel: 714-850-9342

© 1984 Associated Electrics

### AVAILABLE FROM:

**DEMON PRODUCTS**  
79 Northumberland Road  
No Harrow, Middx. HA2 7RA  
Tel: 01 866 5945

**ELITE MODELS**  
145 Newgate Lane  
Mansfield, Notts  
Tel: (0623) 36062

**SRM RACING**  
140 West Street  
Fareham, Hants  
Tel: (0329) 234262

**TED LONGSHAW**  
7 Warren Road  
Orpington, Kent  
Tel: (0689) 55313

# JIM DAVIS

## FOR THE FINEST WHEEL-DEALS

(JIM DAVIS SUPER MODELS IS A PART OF THE HARRY BROOKS ORGANISATION)

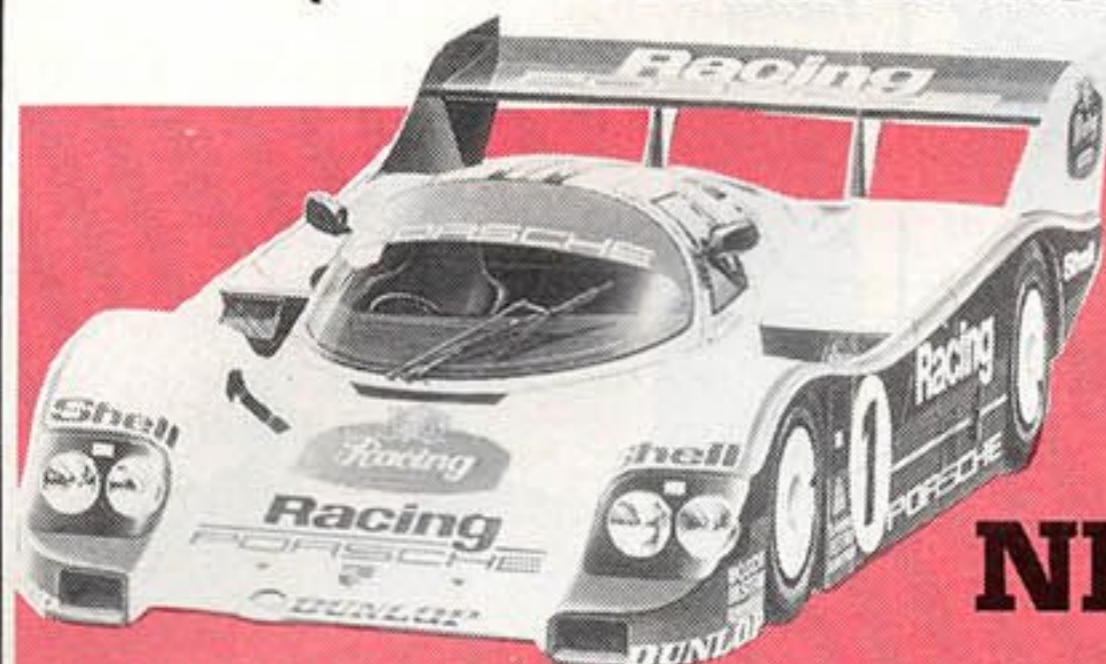

**NEW!**

**Tamiya 24th Scale** How about racing with a car the size of Scalextric radio control! It's unbelievable. We can get you started complete, radio, car, batteries etc. for only **£124.00**

Come and see the cars demonstrated at our own in-store track. Get the "feel" yourself of this new super car-sport.

**STOP PRESS NEW! NEW! LCD thermometer (with peak alarm) £19.95 LCD Tacometer £29.95**

TAMIYA CAR PRICES AND DEALS		
Kit	Our Price	Deal
Hornet	£49.95	£110.00
Striker	£59.50	£111.50
Falcon	£60.00	£120.00
Fox	£75.00	£130.00
Boomerang 4WD	£85.00	£145.00
Bigwig 4WD	£129.95	£199.00
Blackfoot	£80.00	£145.00
Monster Beetle	£80.00	£145.00
Porsche 959 4WD	£129.95	£209.00
The Lunch Box	£64.95	£129.45
Marui Ninja	£94.95	£154.95

Deal includes radio, 7.2v battery pack and "timed" fast charger.

**TO OUR KNOWLEDGE THERE'S NO BETTER DEAL!"**

**HOT SHOT II**  
**OUR PRICE £99.95**  
**DEAL £160.00**

inc. radio, 7.2 acc. & F/charger



Spares & Go-Fast Goodies + very comprehensive stocks for Tamiya

- New FTD 7.2v F/charger with timer and meter unbeatable at ..... £9.95
- Soft FTD 7.2v Racing Bat/Paks ..... only £14.95 (buy 2 for £27.00)
- Ballraces FTD for Tamiya cars . only £1.75 ea. (4 for £6)
- Sanyo FTD 7.2v Bat/Paks ..... £16.95
- Sanyo FTD 8.4v Bat/Paks ..... £19.95

**RADIOS**

by Futaba, Sanwa, KO, Thunder Tiger, Techniplus  
**All at prices that will give you "wheelies". Just give us a ring.**  
 BUT IF YOU WANT, THE ROLLS ROYCE OF RADIOS WE CAN SUPPLY:— MULTIPLEX CAR COMBI **£150.00**

**MORE CARS — PB Mini-Mustang the new winner**

- 4 WD Single Speed **£159.40**
  - 4 WD Auto 2 Speed **£179.95**
  - Schumacher Cat **£175.00**
- Free Sanyo 7.2v Bat/Pak with ea. kit

- Kyosho**
- Rocky 4WD Our Price **£95.00** Deal **£159.00**
  - Optima Our Price **£110.00** Deal **£160.00**
  - Optima Turbo Our Price **£174.95** Deal **£234.95**

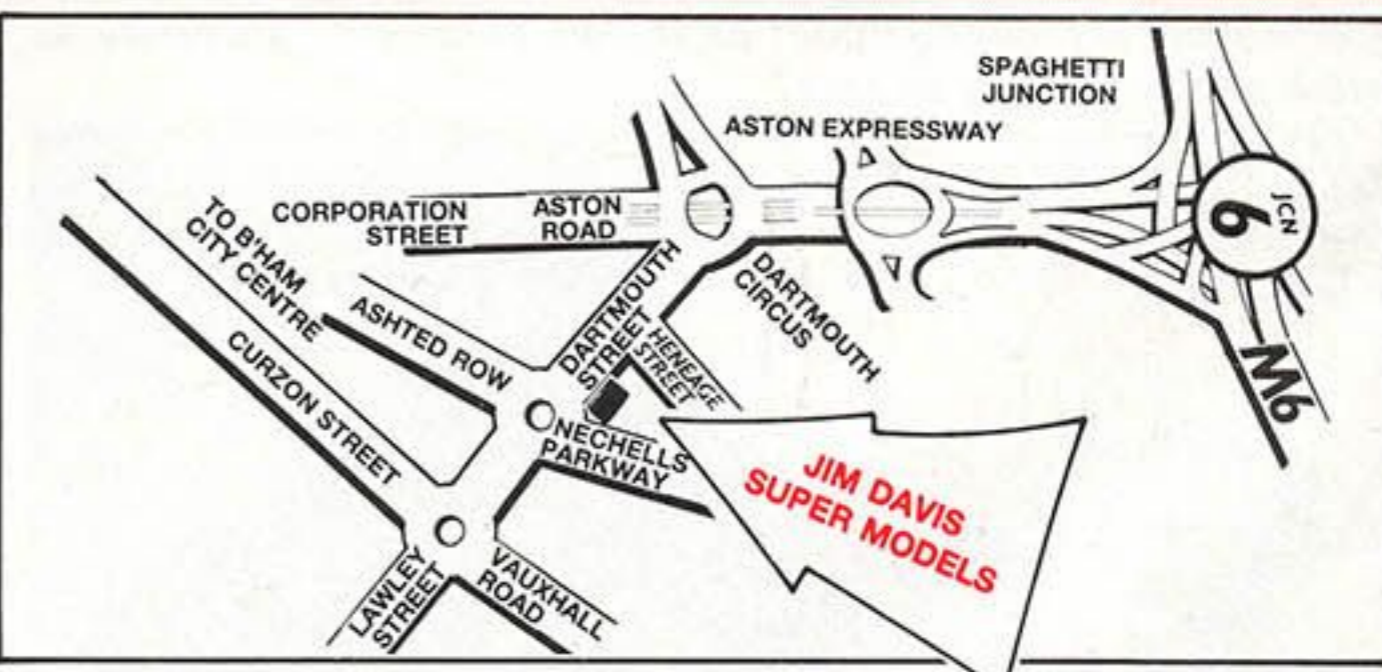

We are also main stockists of Demon, SRM, Parma, Intronic, Schumacher, FTD, Brimod, and P.B. Remember, we're crazy about cars and we are very happy to talk cars and to serve you! Mail Order our speciality, all at best prices but do enclose £1.50 p&p for kits/deals.



**JIM DAVIS SUPER MODELS, UNIT 4, THE PARKWAY, HENEAGE STREET, BIRMINGHAM B7 4LY. PHONE: 021-359-0828**



# TRACK

# TALK

by Chris Evans

Sunday July 19 saw the Rolls Royce Club of Derby play host to a one day Mini-National event, with the 1/12 section special conference taking place later in the day. The racing took place at the Welfare Hall, which although being much smaller than Rolls Royce's normal national venue, provided an adequate area of approximately 12 metres by 17 metres for racing, helped by a maximum of seven cars per heat.

As the 1/12 season now runs from September to June, it is necessary for us to have our own special conference during the summer before the new season begins. In a bid to get a large turnout at the conference, Dave Towell had the good sense to organise a race meeting before hand, which certainly makes the travelling worthwhile although I hate to think how much support the 1/12 section will have at the Annual General Meeting of the BRCA at the end of the year.

Access was available to the hall from Saturday afternoon, so Sunday saw everything prepared ready for racing. Dave must obviously know someone in Rolls Royce's Fabrication Department as all the corners were marked with wooden curbs, all painted red and white giving an extremely professional look to the circuit. The trick was to run with plenty of ground clearance enabling the curbs to be mounted without any difficulty although putting the power

down on them was a different question. Although the club has plans to purchase an AMB autolap count system in the future, for this meeting we had to make do with a manual system via a BBC computer which had a minimum lap time feature and I believe no problems arose from those people claiming missed laps.

Of the sixty places available, forty-six people turned up to race, the notable exceptions being Phil Davies and Pete Farmer, and also Glyn Peglar who was down at Romsey getting his buggy 'dialled in' for the forthcoming World Championships.

With the start of qualifying it became obvious that with an average lap time of about eleven seconds, one crash could easily lose you a lap so getting an extremely clean run was important.

Round one saw Matt Ford ahead of the field with 46 laps 8.29 seconds with his saddle pack Corally, closely followed by the Schumacher 'C' car of Tim Dakin on 46 8.61, with the Associated 12L of Chris Evans in third spot on 45 0.53. The second round saw Tim go just over a lap faster with 47 5.59 to move ahead of Matt who also improved to 47 7.50. Chris managed a 46 5.34 which was now only good enough for sixth place with Pete Riley and his Corally taking third with 46 2.91. The final round saw Matt retake FTD with a 47 1.87

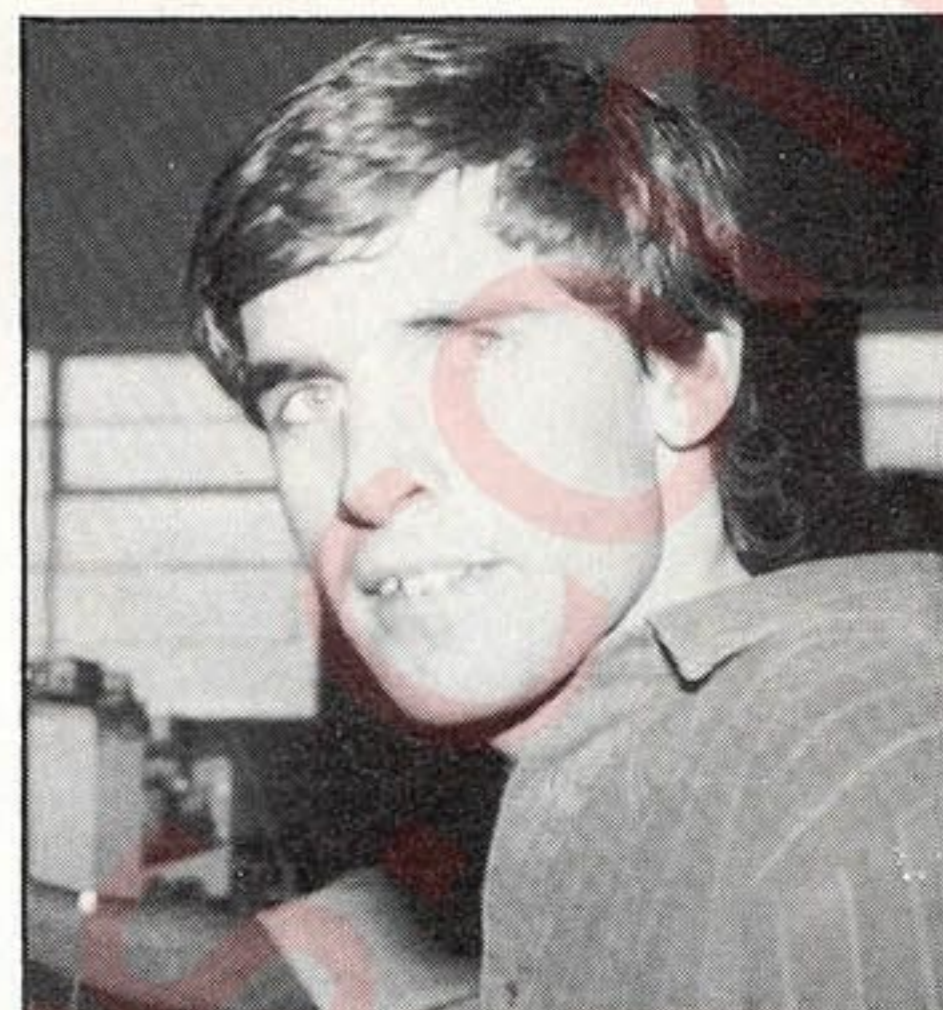

Cliff Finch making a welcome return to racing.



Tim Dakin, the new Standard Class Formula One Champion.

while Tim was unable to improve but his time was good enough to hold second place. Pete also failed to go faster allowing Mark Barford into third spot on 47 9.01 with Andy Smith fourth with 46 1.84. Qualifying in eighth place and just making the 'A' Main was Cliff Finch who was making a welcome return to racing since his car crash earlier in the year.

Although it had been initially decided to run six car finals, as time was pushing on, this was upped to eight cars per final which was going to make things a bit more hectic than the qualifying.

Interesting battery arrangement on Julian Thompson's Corally. Is it a stick pack or a saddle pack?

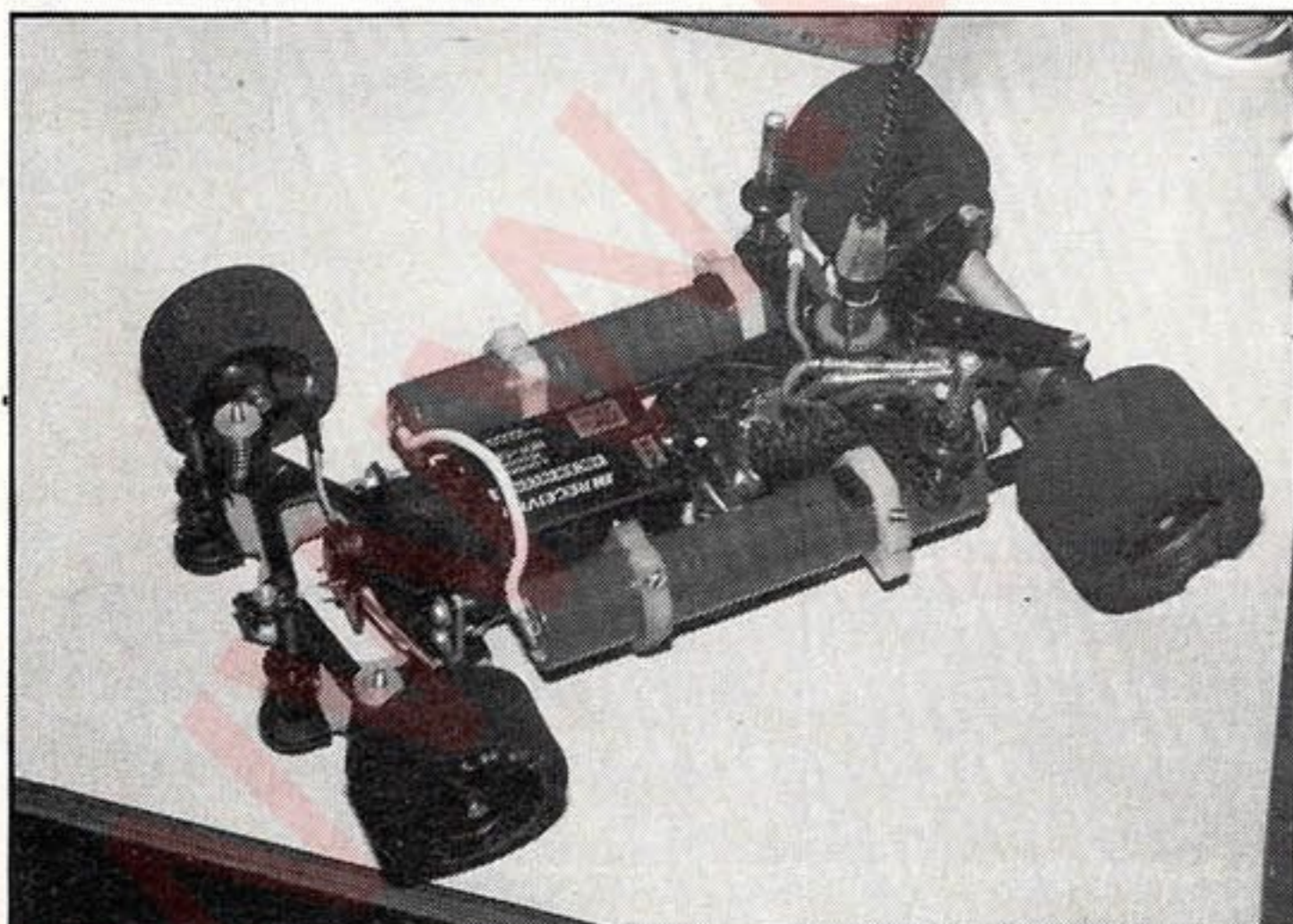

Ian Spashett showing off the new Intronics battery pack to solve his duration problems.

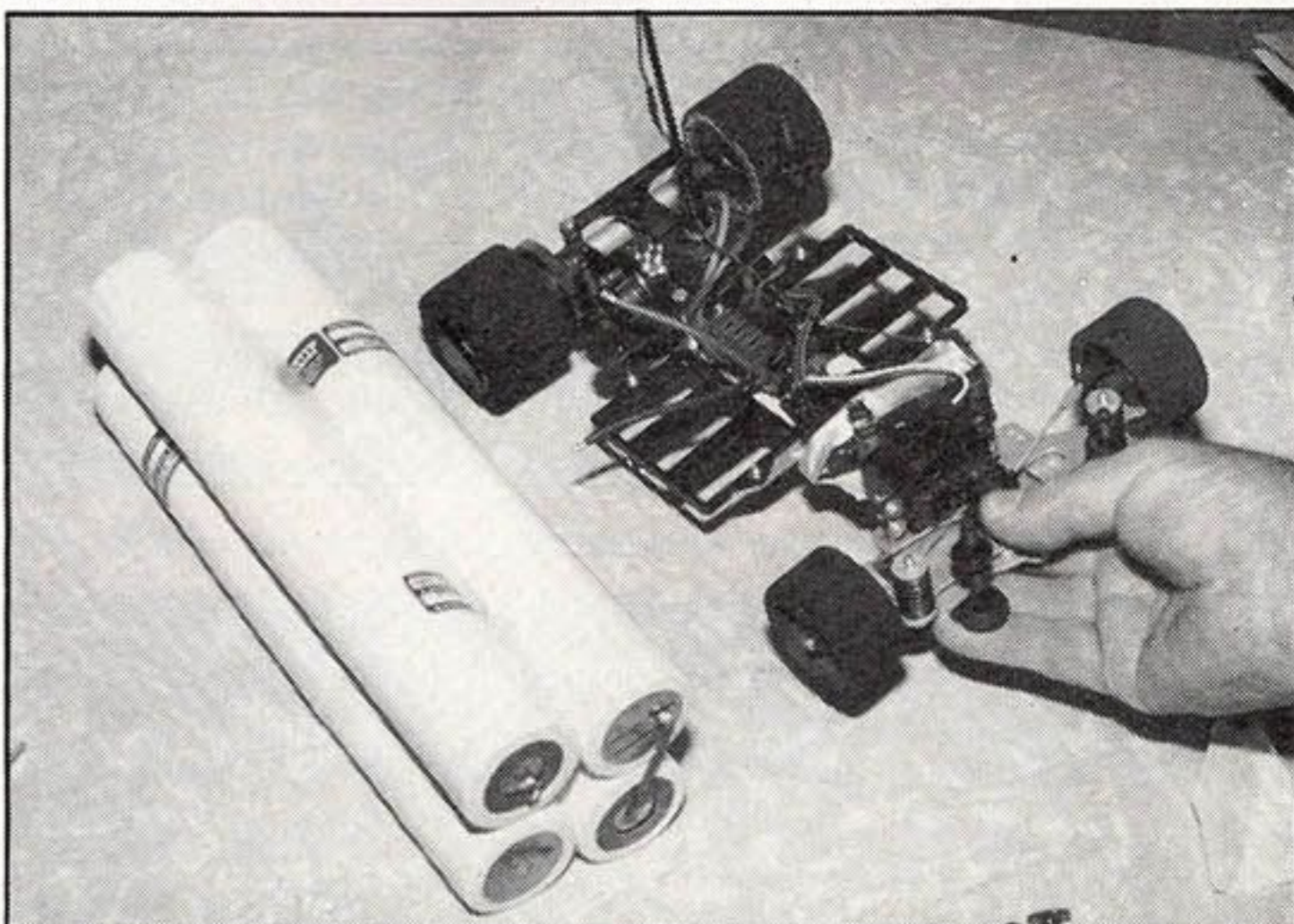

**Results**

**F Final**

1. Phil Wallace 38 11.71
2. Daryl Mellor 34 3.98
3. Roy Giles 32 5.29

**E Final**

1. Eddie Gilbert 41 3.01
2. T. Treadwell 41 15.00
3. John Anderson 40 4.12

**D Final**

1. Ian Spashett 44 8.65
2. Pete Goodyear 44 10.19
3. Kevin Creaser 43 7.38

**C Final**

1. Nigel Piltz 44 8.72
2. Graham Oxford 43 6.08
3. Jason Deardon 41 2.13
4. Howard Pimley 41 3.40
5. Marshall Titley 40 0.00
6. Richard Pickering 40 1.21
7. Jim Spencer 40 11.52
8. Peter Waites 12 15.00

**B Final**

- 1 Chris Hardisty 46 10.11
2. Dave Towell 46 10.72
3. Keith Helmke 45 3.45
4. Pat Hodge 45 4.72
5. Bill Boldison 45 9.84
6. Vince Formosa 44 6.85
7. Jackie Towell 44 11.52
8. Terry Evans 42 2.18

**A Final**

With such a furious pace being set by the A finalists it was inevitable that some laps would be missed by the lap counters. Fortunately with a printout of lap times for each person it was easy to sort out any errors after the race but it made a 'blow by blow' account of the 'A' final by Malc Harris who was not only watching the track as well as the computer screen a virtually impossible task. For once though the final result was a 'carbon copy' of the qualifying.

**Results**

1. Matt Ford 48 9.83
2. Tim Dakin 47 3.04
3. Mark Barford 47 4.06
4. Andy Smith 47 10.64
5. Pete Riley 46 1.77
6. Chris Evans 46 5.85
7. Rob Roy 45 3.29
8. Cliff Finch 42 7.84

After the finals the track was cleared away and the real 'nitty-gritty' began with

**Schumacher PC3 Ammeter Charge complete with leads.**



**The Rolls Royce club's BBC computer used for the lap counting.**

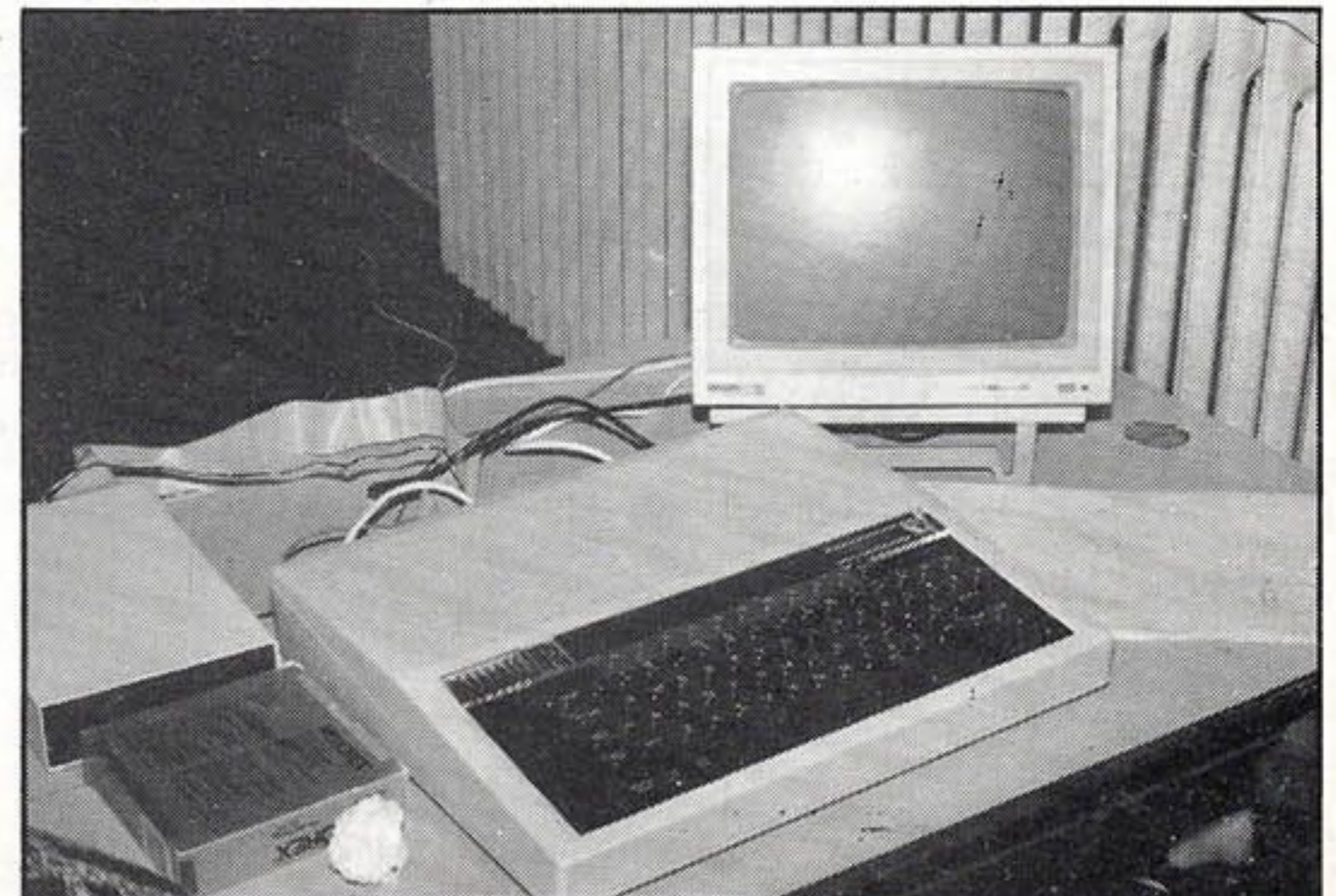

**Pete Goodyear, Standard Class Formula Two Champion.**

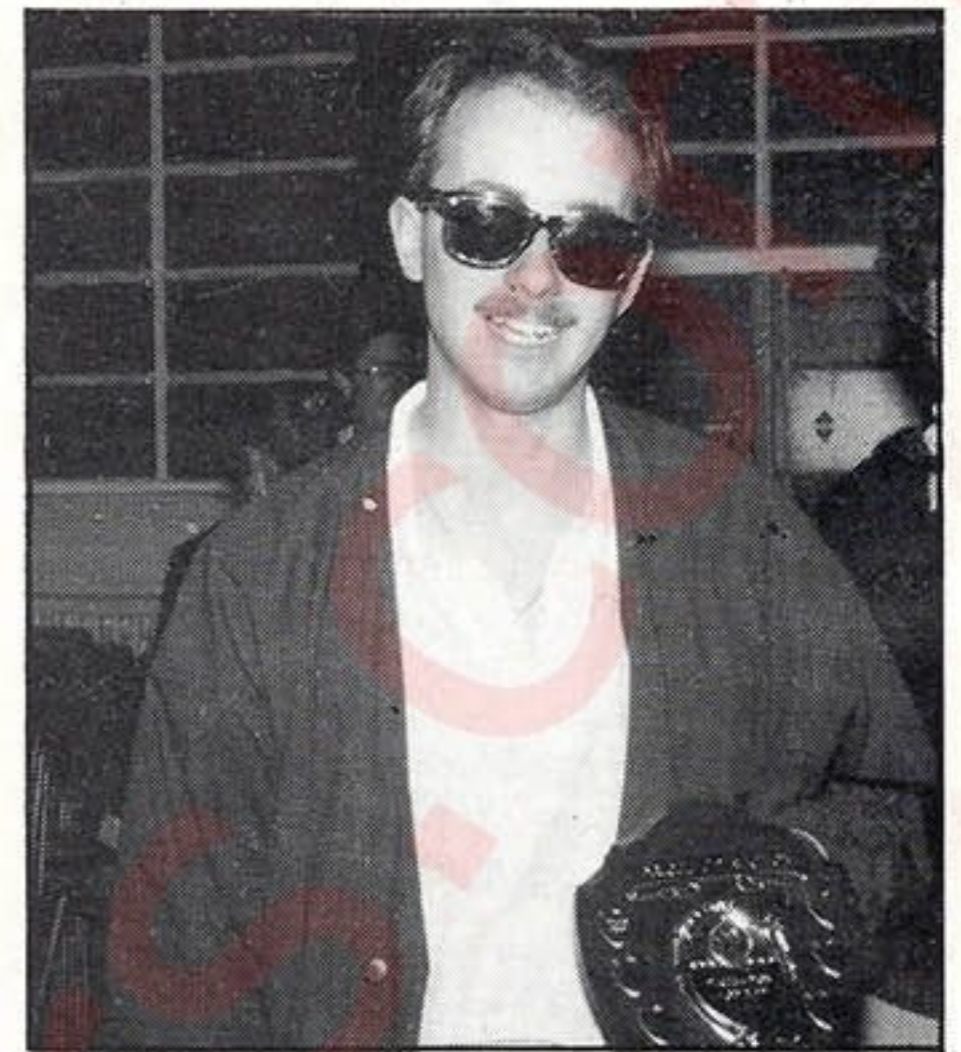

**Phil Davies, Modified Class Formula One Champion.**

the conference. Firstly though the new National Champions were presented with their trophies, except for the modified formula two champion John Robson who was away on holiday. Once again to all our champions 'Well done!'

The conference then followed which went on for over three hours but could have gone on for much longer, and like I have said before, I hope we can get as much support for the BRCA AGM at the end of the year. For all 1/12 racers the minutes of the meeting are reproduced here in full.

**B.R.C.A 1/12 Scale 'Special Conference'**

This meeting was held at Derby on 19 July 1987, at a venue kindly arranged by mem-

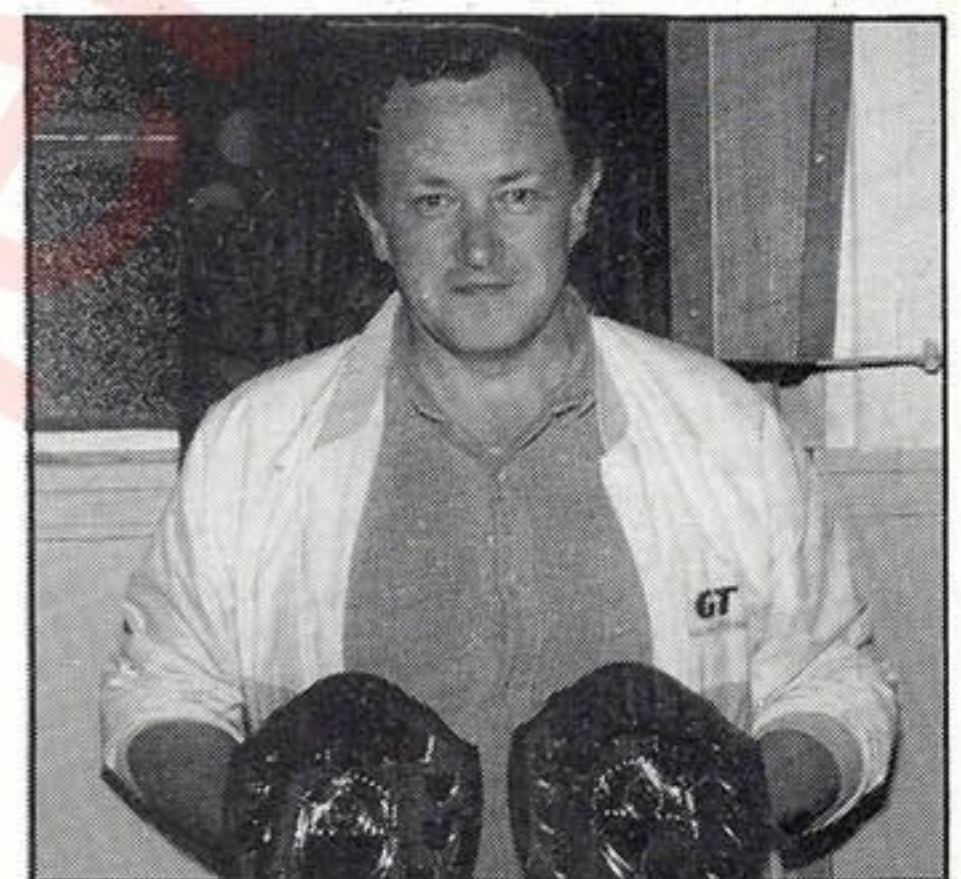

**Malc Harris, the Formula Three Champion for both Standard and Modified Classes.**

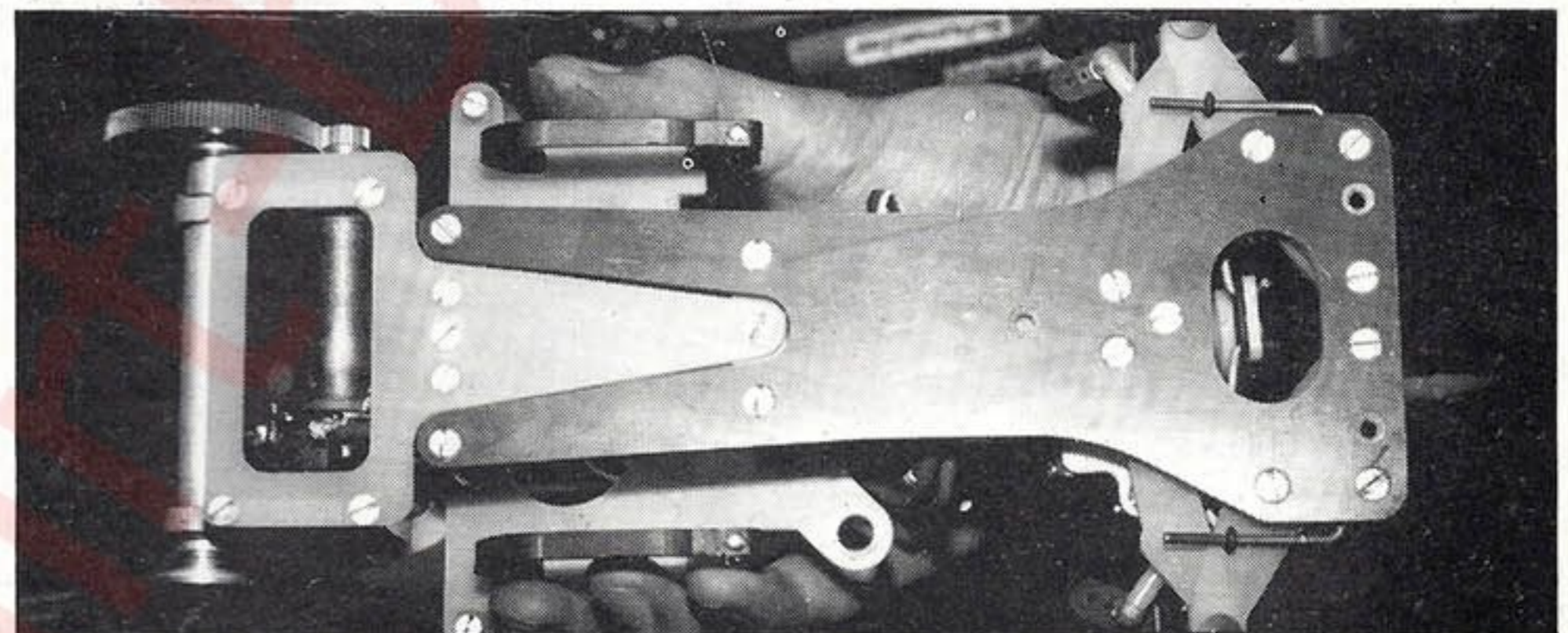

**Kevin Creaser's Schumacher 'C' car utilising a TDC chassis, being 1/8th in. thick, available through SRM.**

bers of the Derby Club.

1) *Apologies for absence.*

Apologies were received from Glyn Peglar and Eddie Hawkins.

2) *Committee proposals for rule changes.*

i) A proposal to amend rule 7.3.3 to read: 'Competitors will move from formula to formula if their current handicap, either exceeds or drops below the break point by 2% at the date of the sanctioned meeting. The handicap for this purpose will be the average of the best two from the last four handicaps. The qualifying officer will make available to the organisers a current list of handicaps as soon as practical before the meeting'. This proposal was carried unanimously.

ii) A proposal to delete rule 7.6 and thereby allow any number of battery packs to be used was discussed. Frank Dakin proposed an amendment: 'do not delete rule 7.6' this was seconded by Mark Jewitt. This was carried by a majority.

iii) A proposal to further amend rule 7.3.3 to read (final sentence) 'In the event of a tie the competitors next best scores will be taken into account'. After some discussion Phil Davies proposed an amendment 'In the event of a tie the best positions within the four should be taken into account, if the scores still tie then the next best scores should count'. This was seconded by Mark Barford. Jim Spencer proposed a further amendment: 'In the event of a tie all competitors scores are to count'. This was seconded by Keith Helmke. Both amendments were defeated by a majority and the original proposal was carried unanimously.

iv) A proposal to change rule 7.9 to eight car finals was discussed. This was carried by a majority of 19 to 15. Therefore rule 7.9 reads: 'Competitors will be given the opportunity to run in a final. The finals must be of the A, B, C format, in the formuli, with 'A' final consisting of the top eight qualifiers, B final of the next eight, and so on'.

v) Phil Davies proposed 'In the event of interference before the start of a race, a



Andy Smith's carbon fibre Schumacher 'C' car chassis.

mandatory delay be applied'. This was seconded by Pete Farmer. After lengthy discussion this was amended, proposed by Rob Roy and seconded by Mark Barford, to Rule 5.59 b 'In the event of interference before the start of a race, a mandatory delay of two minutes be applied — longer at the race directors discretion. All cars must remain on the circuit, any car removed must be under supervision of the race director'. This was carried by a majority of 38 to 5.

vi) Keith Helmke proposed, seconded by Dave Towell 'Team entries must be entered, or confirmed before start of heat one'. Jim Spencer amended this, seconded by Malc Harris, to: Rule 7.4 b (procedural) 'Team members must be entered as part of the team before the end of booking in'. This was carried unanimously.

vii) The staggered start system used an European meetings was discussed at length. As only a minority of people had

seen the system in action it was decided that a trial be arranged Pete Farmer proposed, seconded by Keith Helmke: 'A meeting be organised using the staggered start system for qualifying. At the end of the meeting a vote will be taken as to whether the B.R.C.A. 1/12 section adopt the system'. The meeting supported this proposal with a unanimous vote.

viii) Chris Hardisty informed that an act of parliament making 40 MHz legal has produced a grey area over the legality of 27 MHz.

ix) Price limits were discussed briefly, the conference after consulting members of the trade present decided not to increase or decrease the price limits on motors and speed controllers. Pete Farmer proposed, seconded Phil Davies 'Delete rule 4.8e of general specifications'. The proposal was defeated by 25 votes to 10. Pete Goodyear proposed, seconded Vince Formosa 'Price

### 'A' Final Equipment Chart

Pos	Name	Car	Nicad	Motor	Speed Control	Front Tyre	Rear Tyre	Body	Radio	Servo	Ratio mm/rev
1.	Matt Ford	Corally Saddle Pack	Laser SCR	Parma 26T x 2	Intronics International N.R.	Parma Green	Parma Green	Frewer TOJ	Futaba 2LGX	Futaba 132H	36.5
2.	Tim Dakin	Schumacher 'C' Car	Laser SCR	Parma 26T x 2	Laser N.R.	Parma Green	Parma Green	Sarik TOJ	Futaba 3EGX	Futaba 132H	34.5
3.	Mark Barford	Schumacher 'C' Car	Schumacher Custom Pack SCR	Reedy Green Dot	Schumacher N.R.	TRC Green	TRC Green	Schumacher TOJ	JR Beat 2 Pro	JR	30.20
4.	Andy Smith	Schumacher C Car Carbon Fibre chassis	Laser SCR	Reedy/Schumacher Green Dot	Laser N.R.	TRC Green	Parma Green	Parma March	JR FM	Futaba 132H	30.2
5.	Pete Riley	Corally Stick Type	Technicad SCR	MG 23T x 4	Intronics International	TRC Green	TRC Green	Alpha TOJ	Futaba 3EGX	Futaba 132H	29.55
6.	Chris Evans	Associated RC12L Graphite	Evans Assorted Sanyos SCR	Reedy 27T x 2	Trans Am N.R.	Grand Prix 'C'	Grand Prix 'C'	Sarik TOJ	Multiplex Car Plus	Futaba 132H	34.55
7.	Rob Roy	Associated RC12L Graphite	Laser SCR	MG 23T x 4	Laser N.R.	Asso Green	Asso Green	Associated TOJ	JR Beat 2	Futaba 132H	30.2
8.	Cliff Finch	Schumacher 'C' Car	Schumacher Custom Pack SCR	Reedy Brown Dot	Intronics International N.R.	TRC Green	TRC Green	Schumacher TOJ	JR Beat 2	Futaba 132H	32.80

limit of £30 per set to be applied to cells'. This proposal was defeated by 17 votes to 11.

x) A proposal to award championship points on the basis of handicaps was not seconded.

xi) Officers: a) Chairman; Cecil Schumacher stood down as chairman. John Ford was proposed by Jim Spencer, seconded by Mike Haswell. John was the only candidate and was elected by a unanimous vote. b) Secretary; Rob Roy announced his willingness to continue as secretary. There were no other candidates. c) Qualifying Officer; Phil Davies stood down as qualifying officer Jim Spencer was proposed by Chris Evans seconded by Mike Haswell. There were no other candidates. Jim was elected by a unanimous vote. d) Eligibility Officer; Pete Jones indicated a desire to remain eligibility officer. There were no other candidates.

Northern area representatives; These will remain as before; Mark Jewitt, Mark Barford, Pete Riley & Pete Goodyear.

Central area representatives; These will remain as before; Dave Towell, Chris Evans, Chris Hardisty & Jim Spencer.

Southern area representatives; These will remain as before: Keith Helmke, Glyn Peglar, Pete Winton & Ian Spashett.

The 1/12 section E.F.R.A. representative will continue to be Cecil Schumacher — thanks Cecil.

### 3) Any other business

i) Phil Davies proposed, seconded by Pete Farmer that 'Modified class be defined as premier and run on Sunday'. Mark Barford proposed an amendment, seconded by Keith Helmke that 'delete the name premier from the rule book, and make both classes equal'. This was carried by a majority vote of 20 to 8. Therefore rule 8 becomes: Requirements for the Standard class national championship.

ii) Cecil Schumacher proposed 'The European champion, British, should automatically be selected for the World Championship team'.

Pete Riley proposed that the EFRA rep, Cecil, should propose that EFRA automatically allot the current European Champion a World Championship place, outside his/her Country's allotment.

This was seconded by Keith Helmke and carried unanimously.

iii) Phil Davies proposed seconded by Pete Farmer that 'International teams be selected on the basis of the Modified Championship.'

The proposal was amended by Chris Hardisty seconded by Chris Evans to Rule 12 International teams

'Team selection shall be based upon "exact" modified handicaps. These handicaps will be based upon the current (this seasons) results, with the discretion of the committee.'

This amendment was carried by a majority of 25 to 5.

iv) Conference then discussed the possibility of purchasing an automatic lap timer. The committee was instructed to monitor the situation.

v) Sheila Goodyear proposed seconded by Pete Goodyear that 'At sanctioned meetings members must show their cards so that they can be booked in. Anyone who does not prove membership through the season will be deleted from the championships.'

## National championship 1987/88

September Derby 12/13th

October 1987 Gateshead 24/25th

November 1987 Northampton 28/29th

February 1988 Nantwich 13/14th

March 1988

April 1988 Denmark Eurochamps

May 1988 Chesterfield 28/29th

June 1988 Watford t.b.a.

## Crude — But It Works

Definitely the "go-faster" tip of the month, this one from yours truly, utilising the latest up to date technology available. No doubt a few of you out there using Associated differentials will have experienced problems when using Losi fine pitch gears, the problem being the 96 tooth spur as it does tend to float about a bit when on the axle since the hole in it is a few thou. larger than the boss on the axle, making correct gear meshing virtually impossible since in some places the mesh is loose, while in others the mesh is tight, but don't panic, a simple solution is here. Take your gear and make sure the hole through the centre is clean and totally de-greased. Then put a slight smear of super glue on the inside of the hole and then leave, allowing the glue to dry completely. This slight smear of glue is enough to just remove that "couple of thou." of play and once lubricated the spur still moves freely on the boss, so if you've got any dodgy gears, try it!

## Dutch Grand Prix

Although some of you will already know by now, this year there will be a Grand Prix on the 19th and 20th of September in Baarn, Holland, the same venue as was used for the 1986 Eurochamps. The event is being organised by the Micro Baarn Club and the racing will take place on the same track to be used for the 1988 World Championships.

Racing will be to EFRA rules, on Needle Felt carpet with a track length of approximately 140 metres and width of two to three metres, and of course lap counting by an AMB system.

The event will take place at the Sporthall "De Trits", Geerenweg, Baarn, Holland, and the entry fee is about £12.50.

If any of you out there want to attend, Ian Spashett of Intronics has all the necessary details.

## Schumacher PC3 Ammeter Peak Charger

Having seen a prototype version at the last Chesterfield National, I managed to get a production version for review at the Romsey World Championships from Tim Walden, and the first thing to hit you is that instead of just a polythene bag, the unit now comes in a very "up market" box, but less of the box and onto the charger.

## In Use

The unit has all the necessary wires, plugs and croc clips attached so is ready to be used immediately. Firstly the charger is attached to the 12 volt DC supply and the "OK" LED illuminates. The nicads are then connected and the "OK" LED should remain on. The start button is pressed and the charging is commenced, indicated by the illumination of the red LED and the ammeter now reads 5 amps. For a fully discharged set of cells charging takes about 22 minutes until the Autosensor notices that peak voltage has been attained and then the unit switches to trickle charge, indicated by the

red LED going out.

It is the Autosensor cut off which makes the charger different to many of the other popular chargers on the market since most of them have gone for "thermal cut out" at a selected or pre-selected temperature. With the Schumacher device the unit closely watches the voltage rise during the charge until the voltage peaks. The unit then allows the voltage to drop by 0.03 volts and then switches to trickle charge as at this point the cells will now begin to warm up. However, if you wish the cells to be warmed up prior to the race, which is necessary for the latest SCR cells, pressing the start button again will initiate another 1½ minutes of fast charge to heat the cells.

According to Tim Walden, the unit is pretty foolproof with no damage occurring if the output is short-circuited. If a charged set of nicads are attached and the input is short-circuited, this only results in blowing the external fuse which should always be checked if you experience any problems with the charger.

Overall, as I have already stated, it only differs from its competitors by the way in which peak voltage is detected, then followed by a second warm up stage. The new PC3 is another excellent item from Schumacher.

## Commutator Cleaner

This is produced by Alan Harland (one of those foreign guys with the funny accent) for the cleaning of your commutator on standard type Yokomo motors. The cleaner in itself looks like a slurry, very much like 'T' cut paste as used for car body renovation but the smell is extremely powerful, smelling mainly of ammonia.

To use it, a cotton bud is dipped into the cleaner, pushed down the brush slot and held firmly up against the commutator. The armature is then rotated manually until all scorch marks have been removed. This process is repeated using cotton buds soaked in lighter fuel until the cotton bud is still clean on removal. As a final note it is well worth taking a small pin and gently scraping any muck out from the commutator segments.

At present I think most people use an RS glassfibre brush for commutator cleaning. The glassfibre brush is a quicker method but Alan's cleaner tends to give a brighter finish to the commutator although it takes slightly longer to do, performance of a motor after being cleaned by either method was identical.

Anyone wanting further information should get in touch with Alan at 27 Windsor Terrace, New Kyo, Stanley, County Durham DH9 7JN. Tel. (0207) 237693.

## Warning Note

At the recent Special Conference of the 1/12th section, Jim Spencer was elected as the new Qualifying Officer. Within a couple of weeks of his new appointment Jim has already drawn up a list of non-BRCA members, i.e. those members whose membership has lapsed. At the forthcoming Derby National, anyone whose membership has lapsed will be informed of the fact and the organisers will "turn a blind eye" but at the next National, the British Grand Prix at Gateshead, anyone who is unable to show proof of membership will only qualify for the Formula Four Finals and will not gain points towards the BRCA championships, a situation that did occur last season and now will no longer be tolerated.

# K & B Models

29 Borough Road, Middlesbrough  
Cleveland TS1 4AD  
Tel: 0642 247889

BOTH SHOPS OPEN

9.30 - 5.30 Mon-Sat

Middlesbrough Branch  
Half day Wednesday

# York Model Centre

17 Davygate Centre  
York  
Tel: (0904) 34281

SERVO'S	Our Price
Also available with old plugs	
Futaba S131SH	£44.95
Futaba S132H	£31.00
Futaba S133H	£27.00
Futaba S134	£40.00
Futaba (New) S138	£15.50
Futaba S128	£15.50
Futaba S135S	£35.95
Futaba S138	£16.50
Futaba S130SH	£44.95
Futaba S131S	£44.95

RADIO	Our Price
Futaba Attack	£52.95
Futaba 2LX	£107.50
Futaba Magnum Junior	£89.95
Futaba Magnum	£256.50
Futaba Gold	£251.95
Attack BFR	£62.50
Futaba Micro Receiver	£26.95

CHARGERS	Our Price
TMS Powerton (15 min.) Mains	£25.95
TMS Pacer 6 + 7.2v fast-slow	£15.95
Jester Hercules Auto Fast	£24.95
Jester Fast Charge Lead	£5.95
MFA 5, 6, 7 + 8 cell fast	£16.95
MFA Mains Transformer	£15.95
Acoms Slow Charger 7.2v...NOW	£6.50
7.2 Fast Charger	£20.00
Twin Rapid Charger	£29.95
Mains Rapid Charger	£32.95

MOTORS	Our Price
Demon 27HT	£11.95
Trinity Stockmotor	£14.00
Kyosho Spirit 600	£11.95
Kyosho Le Mans 480T	£22.50
Kyosho Le Mans 480S	£22.50
Kyosho Le Mans 240S	£22.50
Kyosho Le Mans 600E	£12.95
Kyosho Le Mans 36PT	£30.50
540S Std.	£6.50
Parma Porsche	£11.95
Kyosho 480G	£32.50
Kyosho Le Mans 240SB	£35.95
Kyosho Le Mans 360 Gold	£41.00
SRM Screamer 28 Turn	£11.95
SRM Scorcher 27T	£11.95
Demon 22T single	£11.95
Demon 19T single	£11.95
Demon 24T double	£11.95
Demon 22T double	£11.95
Parma Armature	£17.50
Demon Ballraced Can	£14.95

FOX SPARES	Our Price
A Parts Front Bumper	£3.99
B Parts Side Nerf Bars	£2.99
C Parts Rear Uprights	£1.99
D Parts Gearbox	£3.30
F Parts Front Wishbones	£2.99
R Parts Rear Wishbones	£2.65
X Parts	£2.20
Y Parts	£2.20
S Parts Servo Saver	£2.20
Drive Shaft (each)	£8.80
Damper Parts Bag	£4.70
Upper & Lower Chassis	£4.99
Plastic Gear Bag (diff)	£2.45
Fox Body and Wing	£13.99

WILD ONE SPARES	Our Price
Chassis	£4.40
Roll Cage	£3.80
E Parts (Gearbox and Arms)	£5.50
A Parts	£2.75
Nylon Uprights (2)	£2.65
Wild One Body	£8.99
Wheel Spacer (2)	£1.10
Speed Controller	£6.75
Half Shafts (2)	£2.20
Left and Right Bevel Gears	£1.40
Small Bevel Gears (3)	£1.50

HOT SHOT SPARES	Our Price
A & B Parts Roll Cage	£3.70
C Parts Bumper	£2.80
D Parts Spension Uprights	£3.75
E Parts (Various)	£2.80
F Parts Front Wishbones	£2.80
G Parts Front & Rear Gearbox	£6.90
R Parts Rear Wishbones	£2.75
Mechanism Box & Chassis	£3.35
Gear Bag (Differential)	£2.25
Gearbox Joint	£2.80
Propeller Shaft	£2.85
Wheel Axle Black	£3.30
Wheel Axle Silver	£3.30
Body and Wing (Lexan)	£8.80
Pin Spike Tyres Front	£4.20
Pin Spike Tyres Rear	£4.70

NICADS	Our Price
Ever Ready 1.4 7.2v Flat Selected	£19.50
Ever Ready 1.4v 7.2v Tamiya Type	£18.50
Tamiya 7.2v Hump Pack	£21.95
Tamiya 7.2v Flat Packing Pack	£21.95

Ever Ready 1.4 6v Pack	£16.50
Demon Sanyo Yellow Sticks	£18.95
Parma Sanyo Selected	£19.95
Sanyo Red Stick SCR	£19.95
Sanyo Selected Red Sticks SCR	£24.95
Sanyo 8.4v Nicad only	£23.95

ACCESSORIES	Our Price
Triflon Lubricant	£2.50
Damper Oil (2 oz) Lt. Med. Hvy	95p
Motor Pinions (steel 10-18 T)	£1.70
Turbo Props (Motor Treatment)	£1.95
Voltage Regulator	£2.95

Jester Battery + Charger	70p
Ends (pair)	70p
Heatshrink (7.2v battery size)	
Metre	£1.70
Tamiya Polycarbonate Paint	£1.75
Tamiya Bearing (Std.)	£1.45
Tamiya Bearing (8 x 5mm) Hotshot	£1.90
Scorpion Bearing (large)	£2.20
Scorpion Bearing (small)	£1.95
Optima Bearing	£2.00
Motor Suppressor	25p
Motor Brushes (pair)	£1.95
Motor Springs (pair)	95p
Acoms Servo Gears	£1.65
Triflow Grease (50g)	£1.50
Tamiya Thread Lock	£1.50
Frog/Brat/Lancia Diff.	£10.50
Parma Motor Cover	£1.50

HOTSHOT UPRATE PARTS	Our Price
TMS Steel Ball Connectors (4)	£3.25
TMS Steel Central Drive Shaft	£3.95
TMS Front Steering Upright (Single)	£4.25
TMS Steel Front Drive Shafts (pair)	£4.95
TMS Steel Rear Drive Shafts (pair)	£4.95
Mardave Ministock	£34.50

**Congratulations to Simon Cook**  
2nd in 'A' final at  
Scarborough BRCA Meeting

**Congratulations to Johnathan Moore**  
1st in 'B' final at  
Scarborough BRCA Meeting

TYRES	Our Price
Mardave 4x3 (or) fits Ford Ranger	
Hubs	£3.60
Ford Ranger Tyres (pr)	£5.50
Ford Ranger Wheels (4)	£6.50
Grasshopper, Hornet, etc. front tyres	£5.50
Grasshopper, Hornet, etc. rear tyres	£6.50
Frog, Hornet Tyres	£7.50
Dynamite Tyres fronts & rears	£6.50
MRC Fronts	£6.90
MRC Rears	£7.60

HORNET SPARES	Our Price
Hornet, Grasshopper Chassis	£5.75
Hornet, Frog, Brat Bumper	£3.30
Hornet A parts	£3.75
Hornet B Parts	£4.99
Hornet D Parts	£2.50

Large range of screw bags for most cars	
Large range of Parma Products stocked, e.g. (12827) heavy duty steering kit (Fox, Frog, etc.)	£6.45
(12815) heavy duty threaded rod 9" length	95p
Discharge Resistors (2)	£1.45
Parma Resistor Speed Controller with reverse	£18.50
SRM Frog Bush Kit removes all play	£1.99
SRM Hotshot front arm support bracket	£1.50
SRM Fox/Wild One wheel adaptors (set 4)	£5.95
Parma Crystal Case (holds 7 sets)	£2.65
New Attack BFR with built-in voltage regulator in receiver + new Futaba 138 car servos	Only £62.50
Futaba Crystals Splits + Solids	£6.50
Acoms Crystals	£4.25
Attack Combo (no servos) includes transmitter receiver, battery box + switch, crystals (your choice) only	£19.95

BOOMERANG SPARES	Our Price
A Parts	£2.20
B Parts & Bumper	£4.10
C Parts	£3.10
D Parts	£1.45
E Parts	£1.70

OPTION HOUSE ACCESSORIES	Our Price
Motor Guard	£5.50
Side Nerf Bars	£10.25
Celebration Chassis	£25.95
Carbon Fibre Chassis	£29.95
Pressure Oil Dampers (F)	£22.95
Pressure Oil Dampers (R)	£22.95
Low Profile Wheels (4)	£4.95
Low Profile Tyres	£8.75
Torque Clutch 10, 12 & 14	£15.95
Universal Driveshaft for Optima and Rocky (pr)	£19.50

**LOOK**  
**FUTABA ATTACK**  
B.E.C. 2 channel, with servo reversing, fully nicaded complete with charger **ONLY £63.95**

ROCKY SPARES	Our Price
Front Bumper	£2.50
Wheel Set	pr £3.95
Differential Gear Set	£11.95
Front Gearbox	£3.50
Plastic Parts Set	£6.50
Suspension Arm Set	£3.95
Knuckle Arm Set	£5.95
Chassis Deck Plate	£5.95
Chassis Frame	£5.95
Hub Set	£3.95
Ball Link Set	£8.75
Rear Gearbox Set	£11.95

Gear Set	£8.95
Chain Carrier Set	£2.95
Tyre Set	pr £9.50
Damper Set	£18.95
Body	£16.95
Chain	£5.50
Drive Joint Set (gearbox)	£2.95
Front Wheel Axle	pr £4.50
Rear Wheel Drive Axle	pr £4.50
Screw Set	£6.95
Servo Saver Set	£1.95
Decal	£2.50
Speed Controller (board)	£3.50
Speed Controller (contacts)	£2.45
Speed Controller complete	£7.75

PARMA BODIES	Our Price
Dodge Daytona	£11.95
944 Porsche	£11.95
Chenoweth Monogram	£9.95
65 Mustang	£11.95
Yokomo Chenoweth	£9.95
Stinger	£9.95
Sly One	£9.95
Corvette	£11.95
Beetle	£11.95
Grasshopper	£9.95
Spirit Modified	£11.95
Chenoweth	£9.95
Frog Jumper	£9.95
Wells Coyote	£9.95
ZZ Top	£11.95

Bodies are available clear or painted p&p 95p  
Universal body mounts £4.85

Schumacher Servo Saver	£2.25
Schumacher battery clamps	£1.509
Velcro (1ft. length)	£1.25
Wheel adaptors to convert Hotshot to Fox/Wild One	(4) £4.95
Wheel adaptors to convert Optima to Fox/Wild One	(4) £4.95
Reedy Associated Motor Spray	£4.95



F Parts	£2.75
R Parts	£2.75
T Parts	£2.20
U Parts	£1.95
X Parts	(3) £2.20
Y Parts	£2.20
Chassis	£3.30
Propeller Joint	£1.55
Drive Shaft	(each) £3.85
Propeller Shaft	£0.99
Gear Bag	£2.10
Ball Connector Bag	£3.30
Damper Bag	£3.30
Thrust Washer Bag	£1.90
Screw Pin Bag	£1.55
Body, wing, switch & dust covers	£10.50
Supershot Driveshafts	£3.85 each
Supershot Underguard	£2.60

FALCON SPARES	Our Price
A Parts	£3.15
B Parts	£3.15
C Parts	£4.20
D Parts	£2.90
R Parts	£3.15
F Parts	£2.30
X Parts	£0.80
Y Parts	£0.80
Chassis	£2.90
Gear Bag	£2.30
Damper Bag	£4.75
Falcon Body Parts	£14.99
Plastic Joint Shaft Set	£5.20

HP Suspension Set ..... £16.50  
Improves Hotshot Suspension

OPTIMA SPARES	Our Price
OT1 Gear Box	£4.95
OT2 Chain	£4.95
OT3 Wheel Set	(4) £4.95

OT4 King Pin	(4) £22.45
OT5 Joint	(2) £2.35
OT6 Swing Shaft	(2) £5.00
OT7 Rear Plate Set	£6.65
OT8 Front Side Plate	(2) £2.10
OT9 Shock Stay	£2.75
OT11 Suspension shaft	(2) £2.75
OT13 Suspension Arm Set	(2) £2.75
OT14 Under Guard	£2.10
OT15 Front Bumper	£2.10
OT16 Knuckle Arm	£3.90
OT17 Front Shaft	(2) £3.50
OT18 Rear Shaft	(2) £3.50
OT19 Driver Washer	(4) £2.10
OT20 Main Chassis	£5.90
OT21 Screw/Nut Bag	£7.45
22 Body Washer	P10 £2.10
23 Pinion (12T)	£2.10
24 Pinion (15T)	£2.10
OT27 Sprocket Gear Set	£5.95
OT28 Diff Gear Set	£5.90
OT29 O Rings	(10) £1.75
OT31 Pillow Ball	P10 £2.75
OT32 Ball (5.8)	£2.10
OT33 Ball Nut (M2.6)	(10) £2.10
OT34 Plate Set	£2.35
OT35 Upper Rod Set	(8) £2.95
OT36 Pillow Ball (2.6)	(10) £2.75
OT39 E Ring (2.5)	(10) £1.10
OT41 Final Pinion Gear	£2.50
OT42 Servo Saver Set	£2.75
OT44 Decal	£2.35
OT45 Rear Hub	£1.55
OT46 Chain Guide Set	£2.35
OT47 Front Hub Set	£1.95
OT48 Battery Holder Set	(2) £1.95
OT49 Gear Cover Set	£1.95
OT54 Front & Rear Anti-Roll Bars	£7.80
OT26 Driver Figure	£3.50
OT25 Optima Body	£13.00
OT30 Optima Tyres	(pair) £6.95
OT43 Rear Dampers	(pair) £11.65

ACCESS, VISA JUST PHONE YOUR CARD NUMBER FOR SAME DAY DESPATCH.  
PLEASE ADD £1.95 P&P ON KITS AND RADIOS; SERVOS, MOTORS 95p;  
CHARGERS + NICADS £1.50; ACCESSORIES 50p  
PLEASE RING BEFORE ORDERING AS SUPPLIES OF SOME ITEMS ARE INCONSISTENT.  
ALL WRITTEN ENQUIRIES TO BE ACCOMPANIED BY A S.A.E.



# WORLD CHAMPION SCHUMACHER C.A.T.

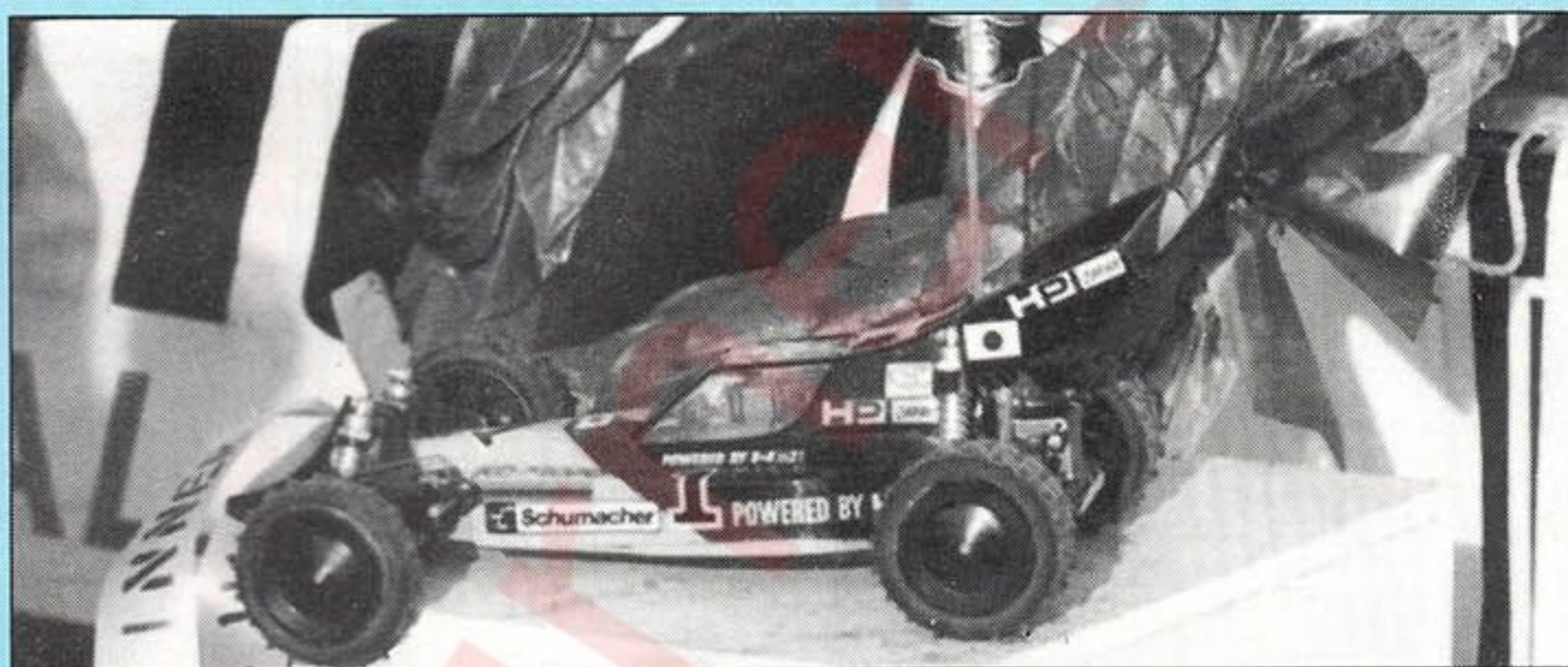
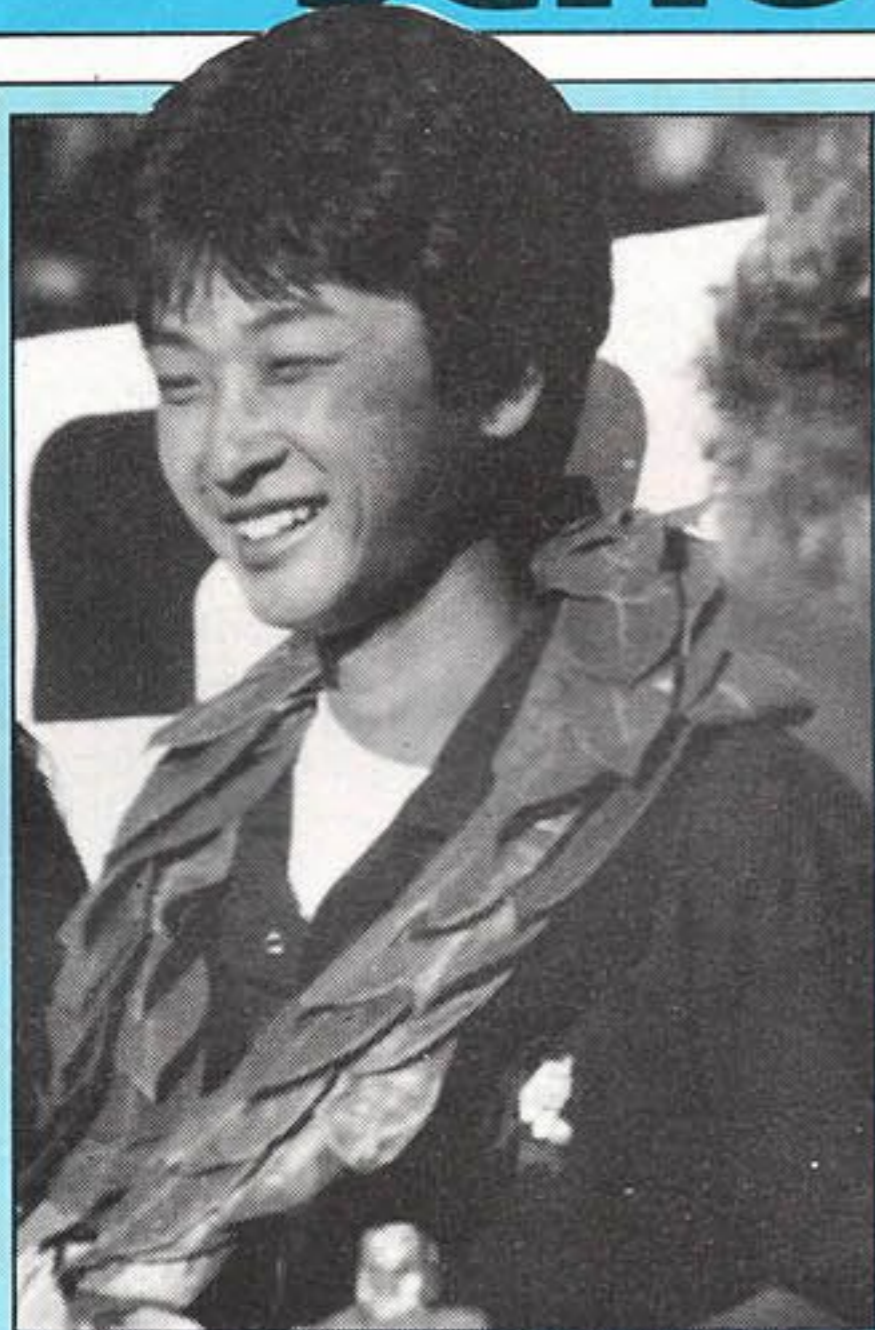

### PRESS RELEASE — CAT WINS IFMAR WORLD CHAMPIONSHIPS

The CAT has been developed by the Schumacher Team to be the ultimate 1/10th scale Competition All Terrain vehicle. Extensive testing over every type of racing surface together with the best engineering and materials have produced this fine machine.

The competition success of the CAT is fantastic, already this year it has won the British, Scandinavian, European, Australian, USA Roar National Championships and now the 1987 IFMAR 4WD WORLD CHAMPIONSHIPS.

The CAT which won the World Championships was not a one off special but was built for the Team by Phil Booth from an "Off The Shelf" Kit using totally standard production parts. Technology that YOU can buy!

The winning specification was a 4WD CAT "XL" fitted with Front Diff. (T526) One Way Drive Shafts (T640) and Schumacher Tyres all round (T651, T655) plus the amazing driving skills of Masami Hirosaka the new World Champion.



### NEW Nicad Capacity Meter

Measures the power in your cells. Lets you select the best packs for winning the biggest races. Also use to prevent dumping by accurately measuring power remaining after each race. Simple to use, press reset, connect cells. When cells are discharged meter shows capacity as a percentage.

### PC3 Ammeter Peak Charger

Housed in a strong metal case with large 6 amp meter for total charging confidence. Fast 5 amp charge with auto cut off and trickle charge FET Power Output stage charges 6 or 7 cell packs from a 12 volt battery. Total protection against short and reverse connections.

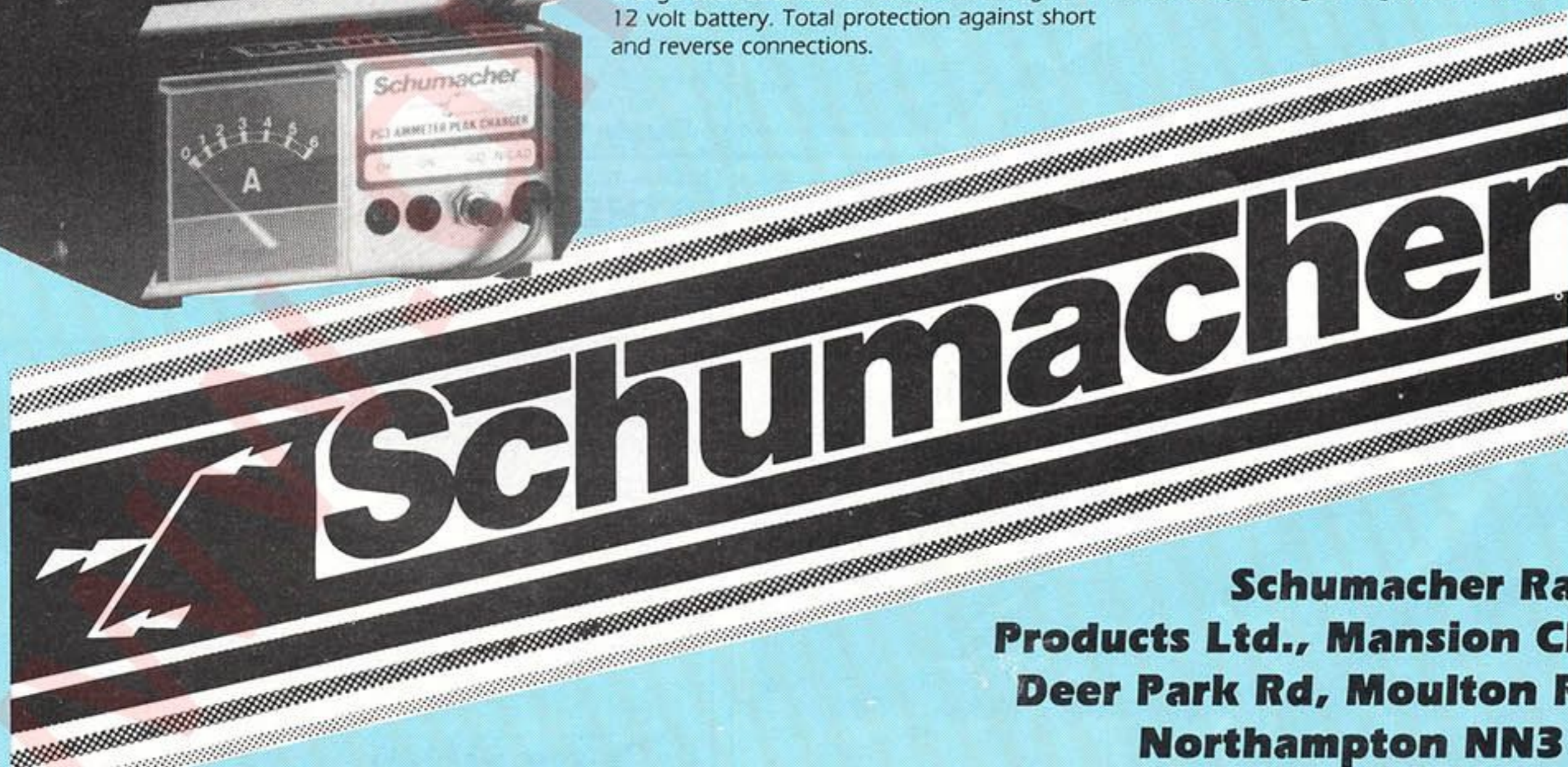

**Schumacher Racing Products Ltd., Mansion Close, Deer Park Rd, Moulton Park, Northampton NN3 1AT ENGLAND**

AVAILABLE FROM GOOD MODEL SHOPS EVERYWHERE

# HOWES

9-10 BROAD STREET, OXFORD, OX1 3AJ. TEL: (0865) 242407

Post and Packing 75p per order. Overseas shipped at cost.

INSTANT CREDIT

VISA, ACCESS, COUNTERSIGN, AMERICAN EXPRESS, LEISURECARD — All Welcome

### 1/10th Electric Buggies and Buggy Deals

Deal Price with the following Radio Equipment

		Acoms Techni-plus	Futaba Attack 2NB Std & BEC	Acoms Techni-plus BEC
Tamiya Vanessa's Lunch Box	£65.95	£130.95	£129.95	£137.95
Tamiya Striker	£57.95	£115.95	£114.95	£122.95
Tamiya Monster Beetle	£86.95	£144.95	£143.95	£151.95
Tamiya Porsche 959, 4WD 1/12th	£135.95		£192.95	£195.95
Tamiya Blackfoot	£78.95	£135.95	£135.95	£143.95
Tamiya Big Wig 4WD	£147.95		£205.95	£213.95
Tamiya Falcon	£63.95	£121.95	£120.95	£128.95
Tamiya Boomerang 4WD	£89.95		£146.95	£154.95
Tamiya Hotshot II 4WD	£107.95		£164.95	£172.95
Tamiya Hornet	£51.95	£109.95	£109.95	
Tamiya Grasshopper	£44.95	£102.95	£101.95	
Marui Ninja 4WD	£94.95	£152.95	£152.95	£160.95
Marui Samurai 4WD	£94.95	£152.95	£152.95	£160.95
Marui Big Bear 1/12th	£64.95	£122.95	£121.95	
Marui Hunter	£62.95	£119.95	£119.95	
Marui Golden Eagle	£49.95	£106.95	£106.95	
Kyosho Salute 4WD	£177.95	£247.95	£247.95	£255.95
Kyosho Rocky 4WD	£99.95	£159.95	£159.95	£167.95
Kyosho Optima Turbo 4WD	£189.95	£248.95	£247.95	£255.95
Kyosho Optima 4WD	£123.95	£181.95	£181.95	£189.95
Kyosho Ultima	£102.95	£159.95	£159.95	£167.95
Mardave Meteor	£53.95	£111.95	£110.95	
<b>Circuit Electric Cars</b>				
Tamiya Porsche 956 Newman	£76.95	£133.95	£133.95	

All deals include the car/buggy, 2ch radio control (4ch with the Bruiser), 7.2v racing rechargeable drive battery (Saft) and either mains slow charger or 12v fast charge lead (please state which charger you require). All deals are also available with the more powerful Tamiya/Sanyo 7.2v racing battery for £7 extra. Some buggies will also accept the 8.4v racing battery, Saft £7 extra, Tamiya £12 extra.

BEC = Receiver battery eliminator circuit.

The drive battery will run a buggy for approximately 5-10 minutes.

Tamiya Bruiser 4WD £209.95 Deal 7.2v with Acoms 4ch Radio £319.00  
Tamiya Blazing Blazer £79.95 Deal 7.2v with Acoms 4ch Radio £189.95

### Ballraces

INCH		METRIC	
1/8" I.D. x 1/4" O.D. F&S	£2.99	3mm I.D. x 6mm O.D. F&S	£2.90
1/8" I.D. x 5/16" O.D. F&S	£2.99	4mm I.D. x 8mm O.D. S	£1.80
3/16" x 5/16" O.D. S	£2.30	4mm I.D. x 8mm O.D. F&S	£1.85
3/16" x 5/16" O.D. F&S	£2.60	5mm I.D. x 8mm O.D. S	£1.70
1/4" x 3/8" O.D. S	£2.60	5mm I.D. x 10mm O.D. S	£1.80
1/4" x 3/8" O.D. F&S	£2.60	5mm I.D. x 11mm O.D. S	£1.40
		6mm I.D. x 10mm O.D. S	£1.80
		6mm I.D. x 10mm O.D. F&S	£1.80

S = Shielded

F&S = Flanged and shielded.

### Ballrace Sets

Hotshot	£20.99
Lunch Box, Big Wig	£14.30
Hornet/Grasshopper	£14.30
Striker, Falcon	£17.10
Boomerang	£28.99
Fox	£5.60
Hotshot	£23.99
Monster Beetle	£14.80
Blackfoot	£14.80
Frog	£11.20
Rough Rider	£16.80
Subaru	£17.40
Ninja	£334.99
Samurai	£27.99
RC10	£36.50
Rocky	£22.50
Optima	£19.99
Progress	£29.99
Scorpion	£24.99

## VANESSA'S LUNCH BOX

£65.95

DEALS from £129.95



## HOTSHOT II

£107.95



Deals from £164.95

## BOOMERANG

£89.95



Deals from £146.95

## STRIKER

£57.96



Deals from £114.95

**Thunder Tiger** THE MOST RELIABLE RADIO CONTROL MODELS

**£12.99**

7.2V 1200mAh

HIGH QUALITY  
**QUICK CHARGER**



**MULTI QUICK CHARGER**

WITH 1:30 MINUTE TIMER FOR RECHARGING NI-CAD BATTERY PACKS



**Thunder Tiger** THE MOST RELIABLE RADIO CONTROL MODELS

**£19.99**

**Tamtech** ★★

**1/24 SCALE RADIO CONTROL CAR SERIES**

**TAMIYA TAMTECH 1/24th R/C CARS**

**TAMTECH SETS**  
Complete with car kit, radio control set, 7.2 volt 270mAh ni-cad battery and mains slow charger

2103 LANCIA LC2 ..... £144.95  
2101 PORSCHE 962C ..... £144.95

**TAMTECH CARS**  
2102 PORSCHE 962 ..... £27.95  
2104 LANCIA LC2 ..... £27.95

**TAMTECH ACCESSORIES**  
5530 7.2 volt 270mAh ni-cad battery ..... £15.49  
5531 Mains slow charger for 5530 ..... £7.50  
5532 Fast charger (12v DC input) for 5530 ..... £23.95

**TAMTECH SPARES**  
2601 Porsche 9620 body parts set ..... £6.99  
2602 Lancia LC2 body parts set ..... £6.99  
2603 Mini black motor (FK-180SH) ..... £6.30  
2604 Sponge tyre A with wheel, 2 x front, 2 x rear ..... £5.50  
2605 Differential and Pinion gear set ..... £1.50  
2606 Porsche 962C decal set ..... £1.60  
2607 Lancia LC2 decal set ..... £1.60  
2608 Sponge tyre set front A ..... £3.99  
2609 Sponge tyre set rear A ..... £3.99  
2610 BF Goodrich 962 decal (left) ..... £1.60  
2611 Sponsor Geest Lancia decal (right) ..... £1.60

**RADIO PARTS**  
1101 Transmitter, CPR unit, servo and crystals ..... £97.50  
1101A Transmitter only ..... £15.00  
1101B CPR (Control Processing Receiver) i.e. Receiver/speed controller and steering servo ..... £89.00  
1102 Crystal set Tx/Rx, band 1 Brown (26.995 MHz) ..... £5.95  
1103 Crystal set Tx/Rx, band 2 Red (27.045) ..... £5.95  
1103 Crystal set Tx/Rx, band 3 Orange (27.095) ..... £5.95  
1104 Crystal set Tx/Rx, band 4 Yellow (27.145) ..... £5.95  
1105 Crystal set Tx/Rx, band 5 Green (27.195) ..... £5.95  
1106 Crystal set Tx/Rx, band 6 Blue (27.255) ..... £5.95



**P.B. MINI MUSTANG**



**PB29 4WD single speed** ..... **£134.00**  
**PB30 4WD automatic 2 speed** ..... **£150.99**

**NINJA 4WD** ..... **£94.95**



**Deals from £152.95**

**MARDAVE METEOR** ..... **£53.95**



**DEAL, Acoms 2ch Techniplus radio, 7.2 volt ni-cad racing pack and charger** ..... **£112.95**

**ACOMS TECHNIDRIVE 2ch Radio** ..... **£41.95**



**KYOSHO SALUTE 4WD** ..... **£177.95**  
**Deals from £247.95**



**HOTSHOT H.P. SUSPENSION SET**

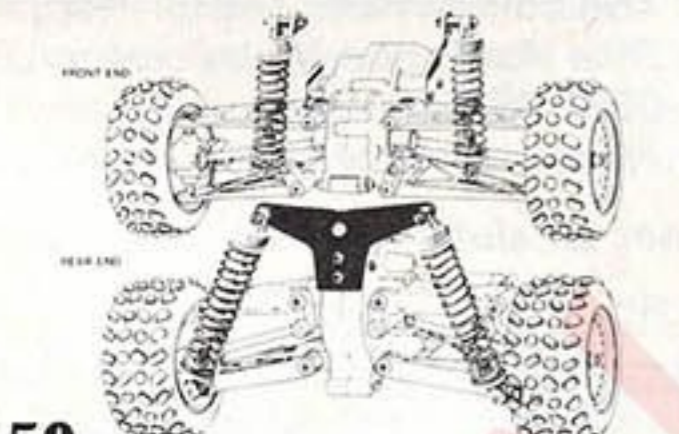

**£16.50**

**Electronic Speed Controllers**

**LASER TEMPERATURE SENSITIVE CHARGER.** Variable rate pulse charger with automatic temperature cut-out £36.95

**LASER COMFET BUG** the ultimate electronic speed controller for 1/10th buggies, compact size (will even fit inside a Hot-shot). Weight 80 grms. Featuring Mosfet forward drive, brakes and full power reverse to get you out of trouble quickly £64.95

**LASER BUG** 1/10th electronic speed controller with full power relay in forward and reverse plus brakes ..... £44.95

**LASER COMPACT BUG.** Spec as above ..... £44.95

**INTRONICS FIREFLY G.T.** Buggy speed controller with full power relay in forward and reverse plus brakes ..... £41.50

All the above electronic speed controllers have a built-in regulated supply to power the receiver.

**TAMIYA**

**5304 C.V.A. Long shock set** ..... **£11.99**  
**5305 C.V.A. Short shock set** ..... **£11.99**

**DYNAMITE TYRES**

TS-2211 Front tyre for Boomerang, Hotshot, Supershot, Fox, Wild One, RC10, Cat, Mini Mustang ..... pair £6.50

TS-3313 Rear tyre for Hornet, Grasshopper, Frog, Superchamp, Sand Scorcher ..... pair £6.50

TS-2214 Rear tyre for Samurai, RC10, Scorpion, Dogfighter ..... pair £6.50

TS-2216/18 Front tyre for Hornet, Grasshopper, Frog, RC10, Superchamp, Sand Scorcher ..... pair £5.75

TS2210/20/30 Front tyre for Fox, Wild One, RC10 ..... pair £5.75

**TAMIYA TYRES**

5268 Oval Block Front Tyres ..... £4.50  
5269 Oval Block Rear Tyres ..... £4.75  
5270 Pin Spike Front Tyres ..... £4.20  
5271 Pin Spike Rear Tyres ..... £4.70  
5303 2WD Pin Spike Front Tyres & Wheels ..... £8.50  
5287 Falcon front tyre and wheel set ..... £5.75  
5288 Falcon rear tyre and wheel set ..... £6.99

**OXFORD**

# STOCK AND OVAL

by Mike Smith

The amount of correspondence over the last few months seeking information about where to go oval racing, has prompted me to include a where and when guide to the oval circuit.

If you are new to the sport you could be forgiven for thinking that oval racing has no organisation to turn to, in fact, I sometimes wonder that myself, last year the sport was controlled by the Radio Stock Car Association, although this governing body left a lot to be desired it did keep the clubs together, if you weren't prepared to give a little then you couldn't expect to receive a lot, as with all associations either big or small a tiny band of dedicated enthusiasts kept things rolling in the face of adverse criticism from those whose words were greater than their actions, it was then thought prudent to join forces with the British Radio Car Association, a much larger group with a much larger membership, but still requiring that main ingredient for success a small band of enthusiasts, who because of increased numbers get even more hassle by even larger groups of people.

The decision to amalgamate with the British Radio Car Association appears to have lost the link that the oval racing clubs needed to maintain their identity.

The blame lies with the oval racing fans who thought, "good! a big well run organisation, won't need me to work, I can just race my car and moan with my brain in neutral.". As one who, in the past been guilty of being a comfy chair critic I will not criticise, those who do their best, but what I can say is that although the blame may be with the oval racing section I can't help the feeling of losing something special in the R.S.C.A.

All the information about oval racing is available from the B.R.C.A. the people to contact for 1/8 Oval are:- Chairman: Steve Talbot, 355 Sewall Highway, Wyken, Coventry CV2 3PB. Tel: 0203 455454. Secretary: Linda Dudley, 8 Barrow Close, Winyates East, Redditch, Worcs B98 0NL. Tel: Redditch 25026. 1/8 representative: Dave Grocock, 27 Suffolk Close, S. Wigston, Leicester LE8. Tel: 0533 782848. For your nearest circuit or local information contact: South: Steve Yap, Jade House, Hendon Wood Lane, Mill Hill, London NW7. Midlands: Dave Grocock as above. North: Terry Dickinson, 7 Brookside Drive, Kersall, Salford M7 0NQ. For the 1/12 oval contact: Chairman Paul Dudley, 8 Barrow

Close, Winyates East, Redditch, Worcs B98 0NL. Tel: Redditch 25026. Secretary: Chris Loughran, 36 Glenhills Blvd., Eyres Monsell, Leicester. Tel: 0533 777529.

Those are the people to contact for the information, now where to race.

1/8 Oval Clubs: A.D.U.R. Model Car Club. Track site, Adur Raceway, Adur Recreation Ground, Shoreham by Sea, Sussex. Track enquiries: Dave Heighes, 310 Portland Road, Hove, East Sussex. Tel: Brighton 419279. How to get there: From Brighton follow the A259 through Shoreham High Street and turn left across Norfolk Bridge. Adur Recreation Ground is on the right hand side.

Aylesbury Model Car Club. Track site: Vale Park, Part Street, Aylesbury, Bucks. Track enquiries: B. J. Dancer, 23 Highbridge Road, Aylesbury, Bucks. How to get there: Follow the A148 Oxford ring road passed A41, A413 junctions. Straight across Cambridge Street, towards A41 ring road. Turn right at Adam's Garage, passed Kwik Fit Euro. At round about take third exit passed Nestles and BPCC into Park St. over the Grand Union canal and Vale Park is on the left.

Bournemouth Radio Car Club. Track site: Turnbury Park Av., West Howe, Bournemouth. Track enquiries: John Cleaves, 41 Richmond Road, Parkstone, Poole Dorset. How to get there: From Ringwood on the A31 continue until Tricketts Cross roundabout. Take the A347 to Ferndown then the A348 to Poole. At the West Howe roundabout turn left into Pool Lane, then second right into Turnbury Park Av., The track is located about half a mile

**1/8 Hot Rod racing is a new venture for the oval circuit not all clubs run Hot Rod events, please contact the club rep.**

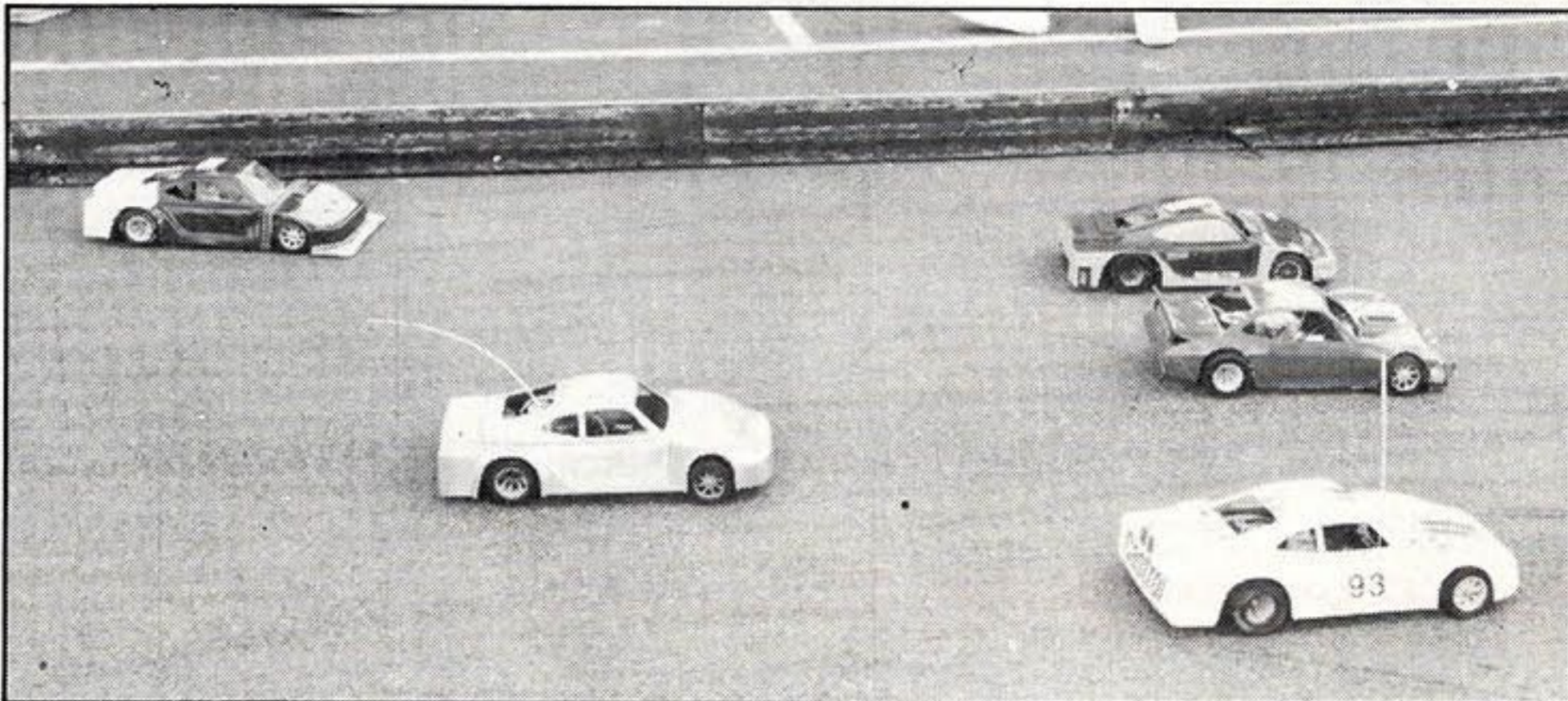

along with access through a gate on the right.

Chessington Radio Car Club. Track site: Leatherhead Football Club Ground, Leatherhead Leisure Centre, Surrey. Track Enquiries: Nik Cohen, 106 Brookside Av., Ashford, Middlesex. Tel: 0784 258881. How to get there: Take the M25 to the Leatherhead turn off, follow the route for the town centre, from there it is sign posted to the leisure centre complex, we are situated in the grounds of the Football Club.

Coventry Model Car Club. Track site: British Legion Club, Leamington Road, Ryton on Dunsmore. Track Enquiries: Derek Bird, 77 Upper Spon St. Coventry, CV1 3BL. Tel: 0203 25111. How to get there: From North or South on the A45 turn into the Leamington Road. The A445 Then 100 yards on the right into the British Legion Club grounds drive past the club premises down a narrow lane to the track.

Lilford Model Car Club. Track site: Lilford Park, Nr. Thrapston, Cambs. Track enquiries: Mike Chilvers, 85 Elliotts Road, March, Cambs, PE15. How to get there: Lilford Park is situated just off the A605 midway between Oundle and Thrapston. From the North turn off the A1 onto the A605 at Peterborough. From the South turn off the A1 onto the A604 at Brampton signposted to Thrapston.

Nottingham R.C. Stockcar Club. Track site: Bashford Hall Miners Welfare, Nuthall Road, Cinderhill Nottingham. Track enquiries: Rob Thorpe, 10 Devonshire Drive, Eastwood, Nottingham NG16 3BE. How to get there: From North or South exit the M1 at junction 26, follow signs towards the A611 then first right at the Headstock pub, 200 yards on the right is the entrance to the Bashford Hall, the track is at the far end of the car park. Please note the club is in the process of moving to a new venue, please check before travelling.

Northern Oval Racing Affiliation. Track site: Nelson & Solne College, Scotland Road, Nelson, Lancs. Track enquiries: Alan Gratton, 1 Warwick Drive, Brierfield, Lancs. Tel: 0282 601409. How to get there: From the South use the M6 to Preston/Blackburn turn off proceed towards Blackburn take the Blackburn ring road to the M65, leave at the Nelson/Barrowford exit, turn left, the College is 50 yards on right, the track is located at the rear of the college.

Radio Stockcar Leicester. Track site: Tiger Raceway, Airmans Rest, Ratby Lane, Leicester. Track enquiries: Lee Bishop, 10 Peregrine Rise Astill Lodge, Leicester LE4 1DR. Tel: 0533 357572. How to get there: From the North leave M1 at junction 22,

head towards Leicester on the A50 for about five miles, turning right at roundabout into Glenfields. Drive through Glenfield past the Forge Steak House, you pass under the M1. Turn left at the next roundabout and back of the M1, The Airmans Rest is on the right. From the South leave the M1 at junction 21/21a towards Leicester on the A46 after one mile turn left onto Braunstone Lane, take the A47 (Hinckley Road) roundabout cross straight over into Ratby Lane, the Airmans Rest is on the left approx. one mile.

Yorkshire Model Stockcar Club. Track site: City Electrical Factors, Brown Lane, Leeds. Track enquiries: Ian Henderson, 52E Church Road., Altofts, Normanton, W. Yorks. Tel: 0924 896515. How to get there: This club is moving to a new venue, please make contact before travelling.

**1/12 Circuits**

Coventry Model Car Club. Track enquiries: as 1/8.

Biddulph Moor Stockcar Club. Track site: Biddulph Moor Village Hall, Hot Lane, Biddulph Moor, Stoke On Trent, Staffs. Track enquiries: Graham Eardley, 8 Chapel Lane, Biddulph Moor, Stoke On Trent, Staffs.

Buntingford And District Club. Track site: Great Homestead Village Hall. Track enquiries: Roy Jones, 92 Ware Road, Hertford, Herts.

Hawkhurst Stockcar Club. Track site: W. I. Hall, Cophall Av., Hawkhurst, East Sussex. Track enquiries: Tom Cox, 24 Chyllside Road, Northiam, Sussex.

Leicester Electis Stocks. Track site: Newfounpool Neighbourhood Centre, Pool Road, Leicester. Track enquiries: Chris Loughran, 36 Glenhills Blvd., Eyres Monsell. Leicester. Tel: 0533 777529.

Nuneaton Radio Stockcars. Track site: Eaton Club Meadows St., Nuneaton, Warwickshire. Track enquiries: Trevor Tennant, 2 Cardigan Road, Bedworth, Warks. CV12 0LY.

Thamer View Stockcar Club. Track site: Thames View Community Centre, Bastable Av., Barking Essex. Track enquiries: Roy Jones, 92 Ware Road, Hertford, Herts.

Urmston R/C Stockcar Club. Track site: St. Clements Branch Church, Humphrey Lane, Urmston, Manchester. Track enquiries: Alan Crossland, 115 Firwood Avenue, Urmston, Manchester. Tel: 061 8654601.

Please note it would be prudent to check with the club concerned before travelling to any venue. Please could all clubs who hold regular meetings for either Stocks, Minis, or Hotrods, contact me with particulars etc.

**Pitstop Models 1/12 Stockcar British Open Meeting — 1987.**

This year, the British open moved southwards from the Midlands, to the Thames View Club, my thanks to them for hosting the meeting, despite a very poor turnout of 13 drivers! (I must admit that I didn't go, due to domestic problems, so thanks to Roy Jones for the write-up and results.)

The early heats set the pace needed to qualify, as Jon Smith took heat one with 57. This was beaten in heat two by local driver Ian Skinner, on 63. This was the best of the round, although Clive Buckler managed a 62.

Ian was again on the pace in round two with another 63, demoting Andy Tollett into second place, on 52. Clive tried hard in



The Stock Car stands from M.M.D. these are ideal for your pit box.

his second run, but once again had to settle for a second-best 62.

The closest race saw John Smith fending off Roy Jones and Matthew Pettitt, Jon winning with 57. Roy and Matthew tied for second, on 55.

Andy Tollett got things together in round three scoring a 57. Clive Buckler took the top score with a 58, as everyone started to struggle for grip.

Clive again took the honours in round four with a 59, beating Roy into second place on 58. Fred Hofman took third spot, with 56. Roy tells me that his Mk 1 Schumacher is getting a bit old now, and he's going off to build himself another car during the summer. (Summer? What's that?)

The final round again went to Clive, with a 61, leaving Roy, Fred and Andy all on 57.

Normally, the top seven drivers would go through to the eight car final, but with the lack of drivers, a six car final was planned, the top five qualifiers being as follows:- Cliver Buckler (242 laps), Ian Skinner (235), Roy Jones (225), Jon Smith (225) Andy Tollett (220).

**Consolation**

Fred Hofman (219 laps), Dave Pettitt (212), Greg Pettitt (198), Matthew Pettitt (198), Steve Mayhew (140), Robin Shaw (101).

Fred Hofman had a good start, as he missed the usual first-corner cranage, but after nine laps he was forced out with a broken wire on the motor. Two laps later, Dave Pettitt suffered the same fate, and so we had lost the top two qualifiers inside the first minute of the race. That left Greg to go

through to the front, and despite a lot of attention from brother Matthew, he held on to the lead, to go into the final, winning with 53 to 46.

**Final**

Roy "made his usual big race bad start", and by the time he knew what was happening, he was three laps down. Up at the front, Clive and Ian were swapping places, all the while pulling out a lead on Jon and Andy. Greg was dropping back, not able to keep with the pace, whilst Roy was now chasing Greg, Andy, and Jon.

At the finish, Ian had pulled out almost a lap on Clive, 59 to 58. Andy and Jon were next, both on 57, with Roy on 56, and Greg on 50.

My congratulations go to Ian Skinner, the 1987 British Open Champion, and my thanks to Roy, the Thames View Club, and to Pitstop Models for their support.

Junior Trophy ... M. Pettitt.

Concours ... D. Pettitt

1/12 Stockcars British Open Thames View, 1987. Sponsored by Pitstop Models.

Best Blue — D. Pettitt.

Best Yellow — M. Pettitt.

Best White — R. Shaw.

**1/12 Stock Car Nationals Cancelled**

It would sadly appear that the remainder of the electric Stock Car Nationals have had to be cancelled due to lack of interest. How this has come about is difficult to assess, it would appear that although the National events may have been given the elbow by

**National Tech Chart**

Name	Car Type	Cells	Gears	F. Tyres	R. Tyres	Speed
1 I. Skinner	S/macher Jones/2	Sanyo Select	12:48	Hard	S/Soft Neo	Home Made
2 C. Buckler	S/Macher Mk2	Sanyo CS	11:50	Hard in Soft out	Soft	M/dave
3 A. Tollett	S/Macher Mk2	Sanyo CS	11:50	Hard in Med Out	Soft	Parma
4 J. Smith	Jones B/Brick	Parma Sanyo	13:50	Hard in Soft out	Soft Neo	M/dave
5 R. Jones	S/Macher Mk1 Mod	Demon Sanyo	13:53	Med. Soft Neo	S/Soft Neo	Home Made
6 G. Pettitt	Jones B/Brick	Parma Sanyo	13:50	Soft Neo	Soft Neo	M/dave
7 M. Pettitt	Jones B/brick	Sanyo Select	13:50	Hard in Med out	Soft Neo	M/dave
8 S. Mayhew	M/fied M/dave	Sanyo	12:50	Medium	Armaflex	Kyosho

the 1/2 zealots, down at grass roots everything would appear to be thriving with the club event still boasting growing members.

I can only assume that falling entries are due to perhaps an undesirable element at national events that is putting the would be champions off, or maybe car development over the last few years has been too controversial for the rank and file members. I believe one club with a large regular attendance held one national round and were so disillusioned with the whole event that they refused to host another and slipped back to the club level racing with their own set of rules, that they say have kept a steady growth to membership. For whatever reason and there must be more than one, let's hope that lessons can be learned and perhaps next year the national fixtures can yet again attract the support to which the sport deserves.

**In Stock**

Two items for this issue both for the 1/8 Stock car. Firstly, a chrome plated, sprung car stands to fit your pit box, these are available direct from Motile Model Development, price £7.50 plus p & p.

Secondly, yet another stock body shell from Mardave, this one is very special and will be easily recognised by those with a few years of racing under their belts as the world beating shell of former World Champion Bob Clayfield, sadly now retired from racing. Bob featured on the front cover of Radio Race Car's second edition some six years ago, times may have changed but the distinctive shape of the car shell that took the world remains as stylish as ever. It has taken years for Bob to finally release the mould allowing Mardave to produce the Clayfield classic. Available through Mardave stockists price £3.00 plus p & p if applicable.

**Mike Smith Loses Weight In All The Right Places**

When you race I.C. stockcars the oval circuit can be less than tolerant on your pride and joy. All those months of nerfing and nudging does eventually bring you to a conclusion, that perhaps it was time you built a new stock car!

The old one had given me long service, its front end was getting a little tired, the kingpins no longer reigned supreme, the track rods didn't keep you on the track, the stub axles were getting worn and the ball joints, well I wanted to go down the straight as swift as an arrow, it accepted the arrow analogy and buried itself in the fence at the end of the straight.

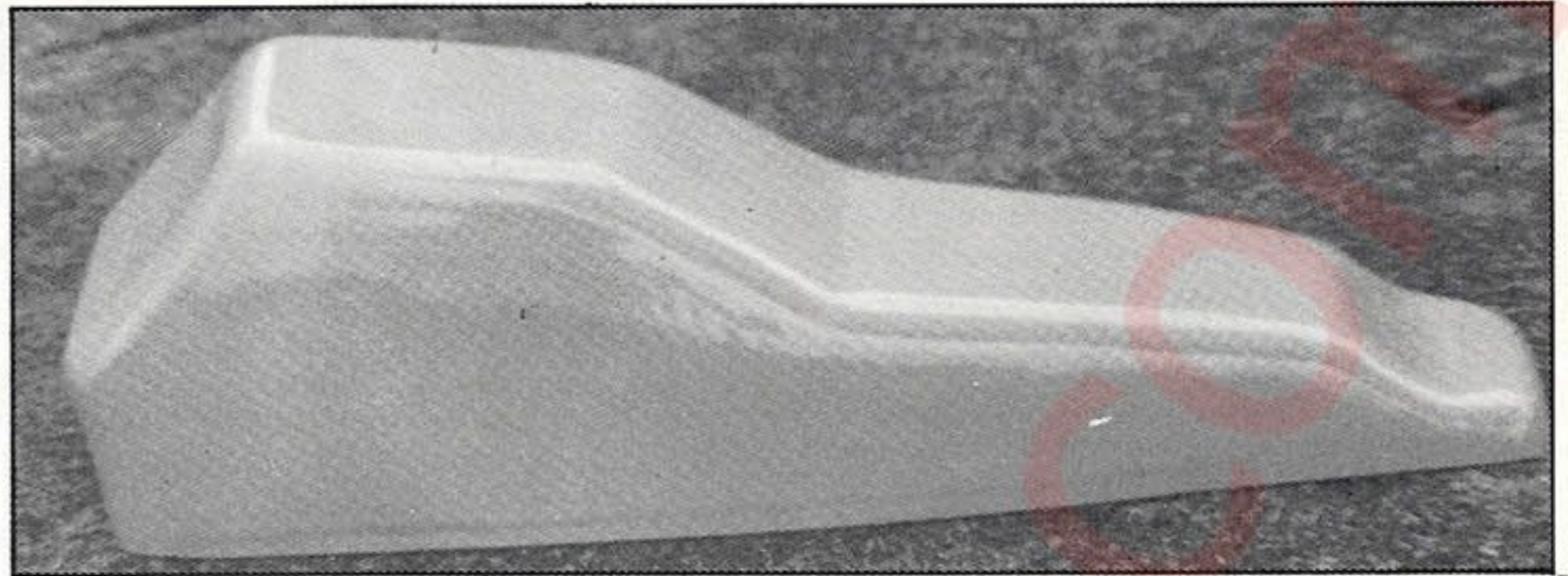

The Clayfield Classic another new body shell from your Mardave stockist, this one is designed by former World Champion Bob Clayfield.

**The Chassis**

The main stay of the I.C. stock car is the chassis, this hunk of steel has to be extremely strong to take the punishment that a contact sport can and will dish out, the problem with strength is it unfortunately in stock car terms means weight, the legal weight for a stock car laid down by the British Radio Car Association is 2.72 kilos (6lb) minimum weight and 3.63 kilos (8lb) maximum weight, most stock cars weigh in at just under the legal maximum.

I have always driven cars that were heavy, following the theory that the heavier they are the harder to shift. This tank like approach to bulldozer driving can be effective, but the fact remains that weight is detrimental to speed, if the weight is below the centre of gravity then it can have a stabilising effect, in fact this is the only place to carry that excess baggage. Anything above the centre line has a detrimental effect, the wheels them-

selves although partly below the centre line are the exception, as they are weight which is un-sprung. The standard mardave chassis is of good strong construction the very recent ones are now incorporating extra strength in the front end by bending the frontplate at the front and rear. So this was where we start.

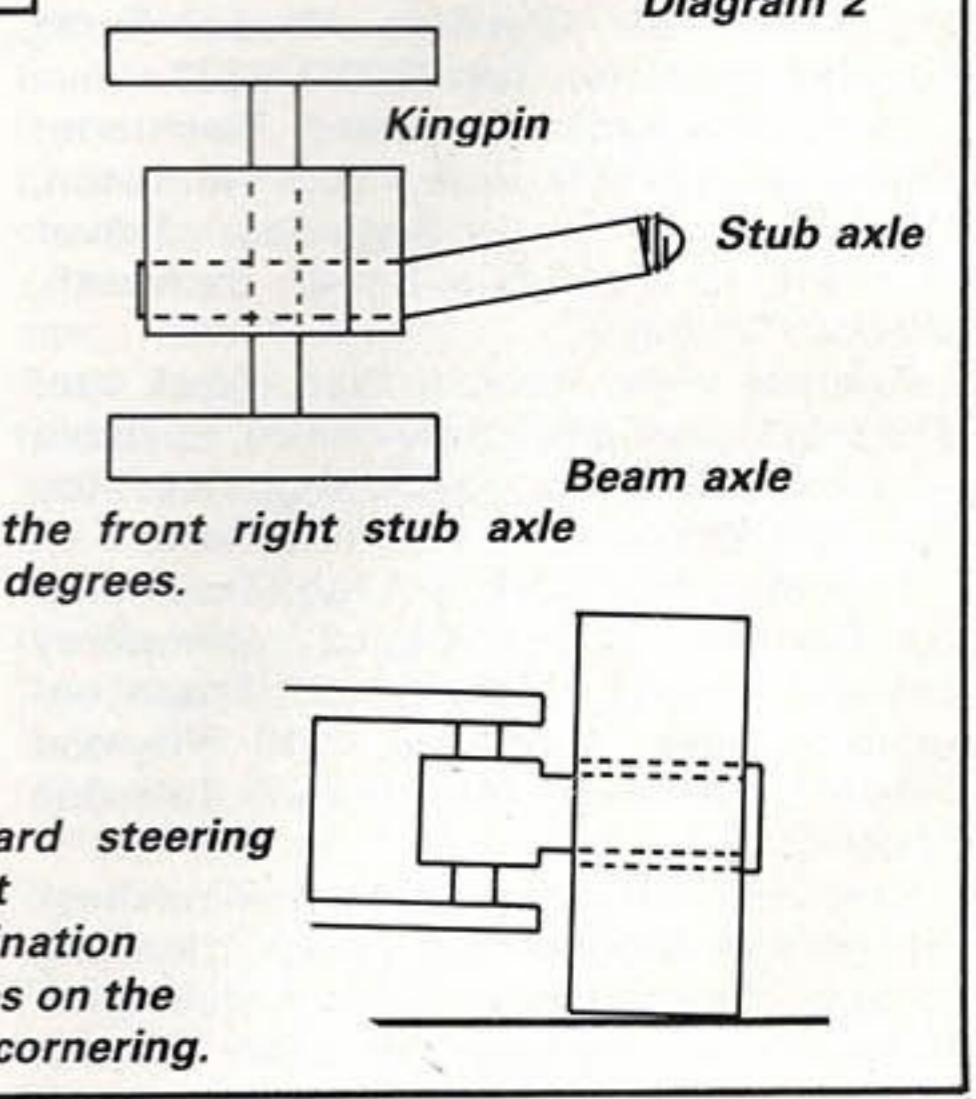
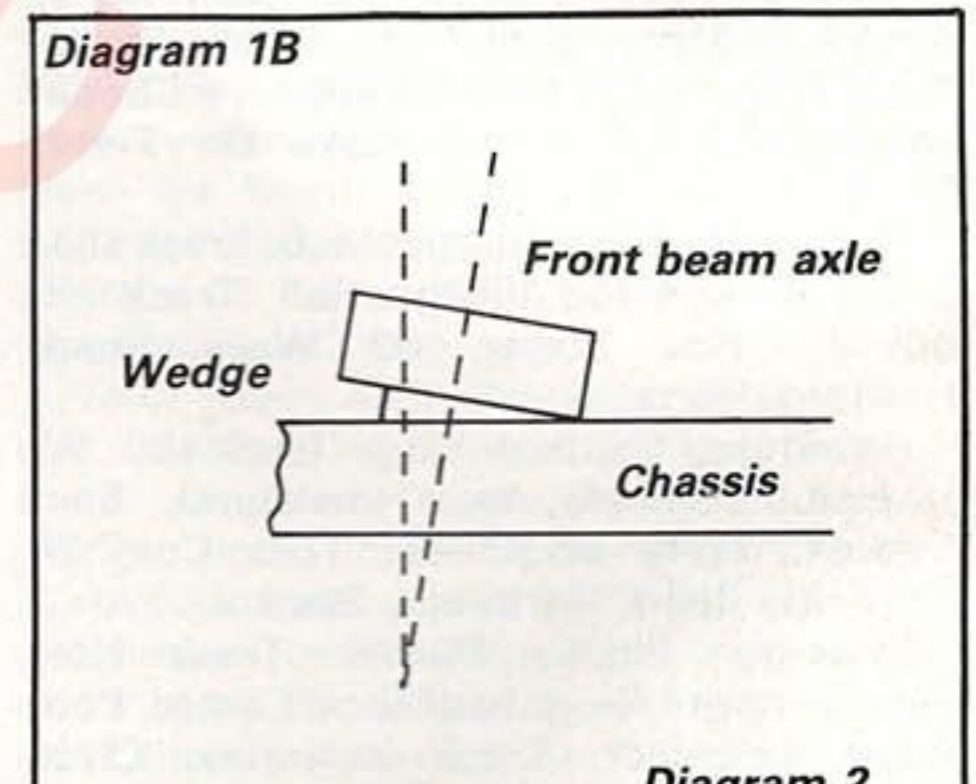
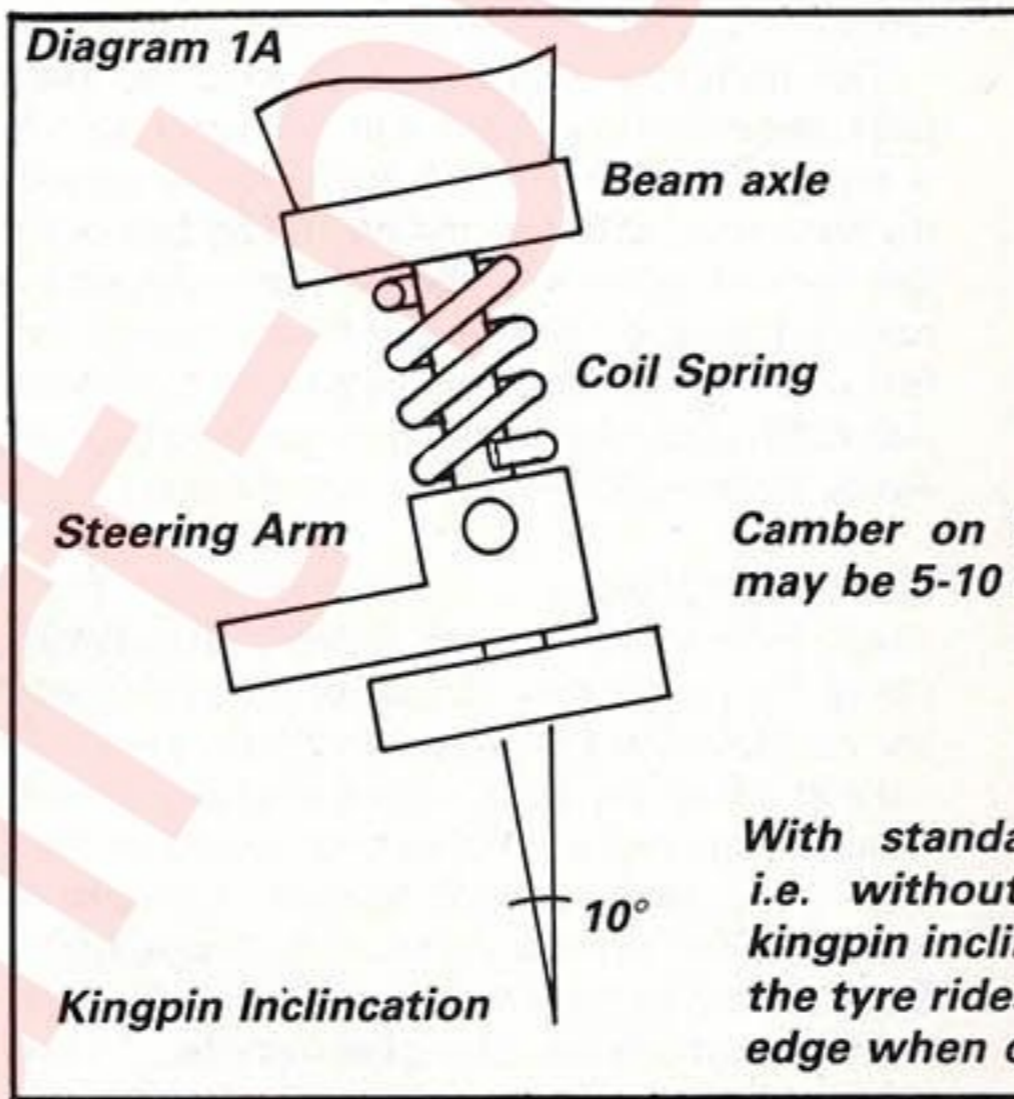

The finished car, with the new Clayfield classic body shell as featured in In Stock.



By placing wedges under the top side of the front axle beam you can incline the beam axle which inclines the kingpins.

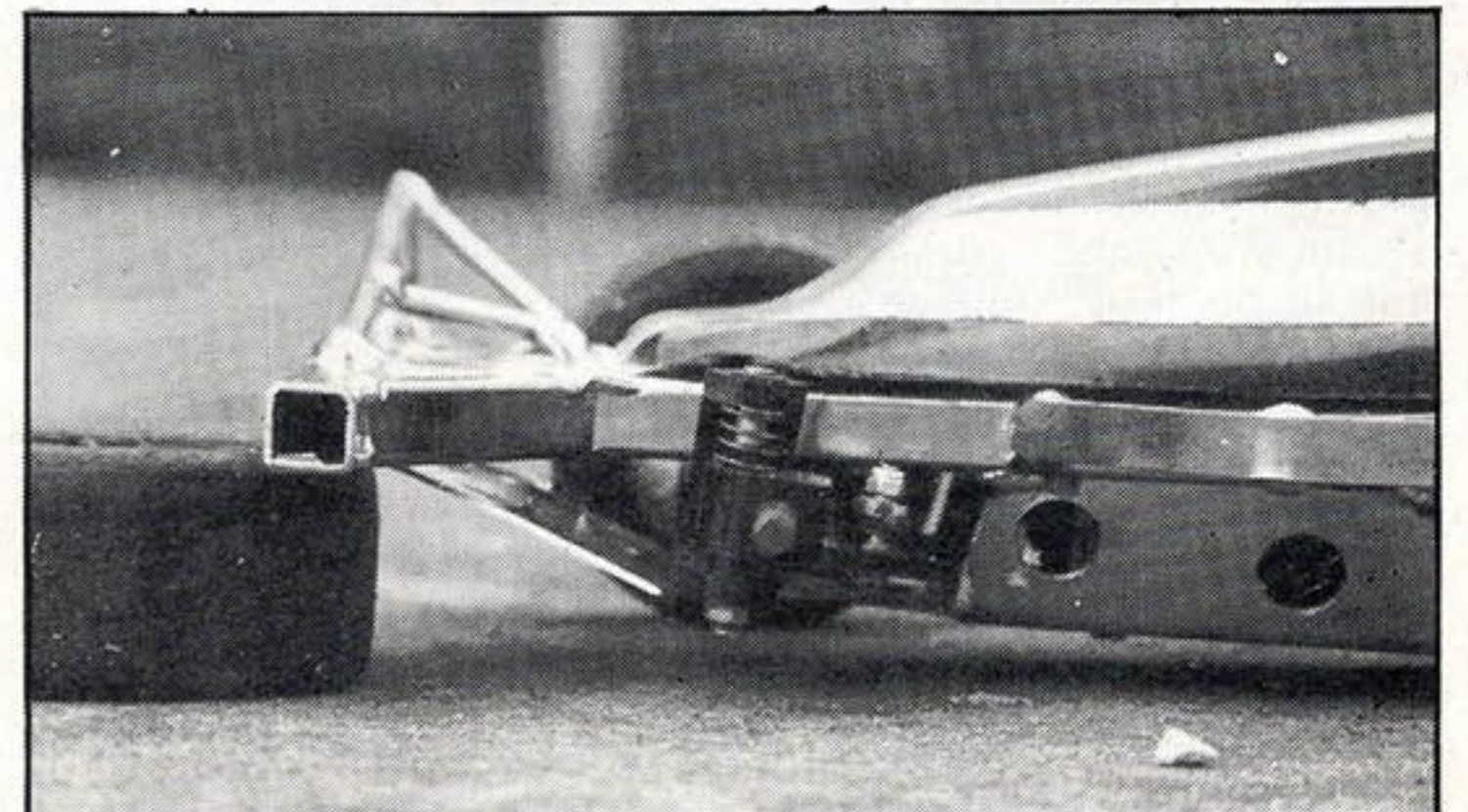

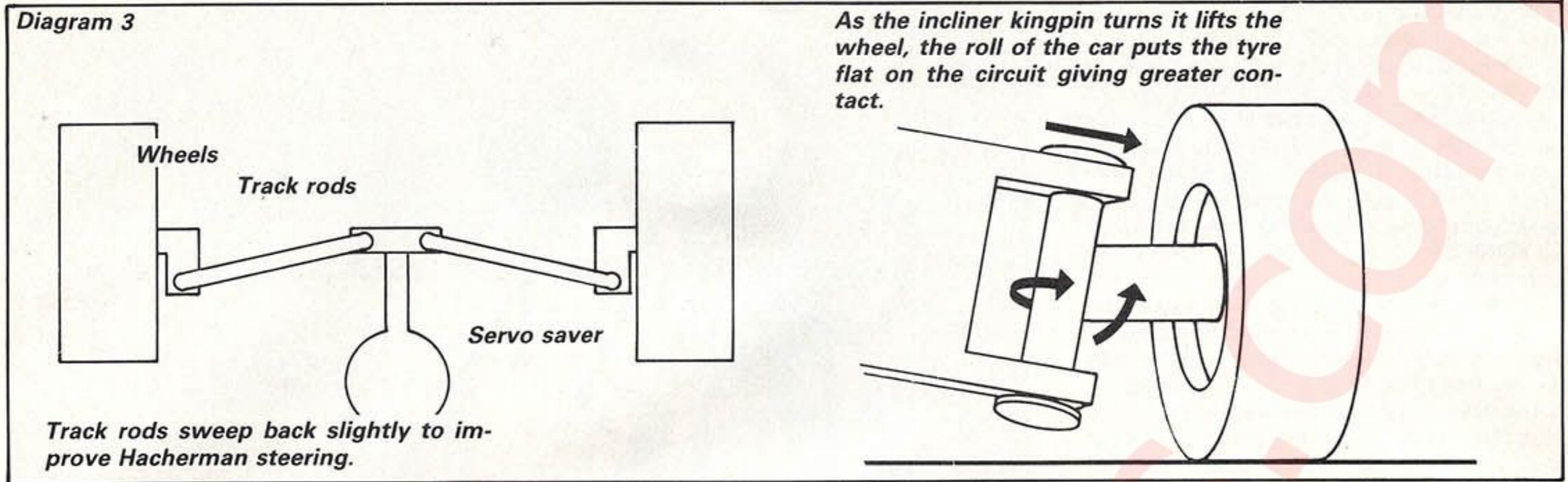

Purchasing a standard chassis which had been chromed to dispense with the need for painting also to reduce noise levels and retain heat, whoops! it's that double glazing sales pitch that gets you when you least expect it.

So starting with a standard chassis, it was decided to remove anything from the main rails or cross members may reduce weight, but would also reduce strength which was not the intention.

The designer and constructor of the Mardave chassis is a man called Stew Busby, his design experience far exceeds that of mine so the basic tried and proved lay out would have to remain unchanged, as stated earlier to each is own trade.

The only safe place to take away a little weight is in the area of the steel under tray, the earlier Mardave chassis did not have the one piece steel tray, as these chassis still performed well then it would seem safe to assume that providing that we worked with a little care and not over do things, then a loss of weight could be achieved without a loss in strength.

Some drivers will insist that the standard chassis is not strong enough for their style of driving and will advocate even more weight be added in certain areas, but adding weight to compensate for bad driving is not the answer. Of course it isn't always your bad driving that causes damage but it is bad driving somewhere by somebody, that is little consolation when you have to retire with a bent chassis, but from my experience the type of shunt that causes the damage will still happen no matter how strong your car is.

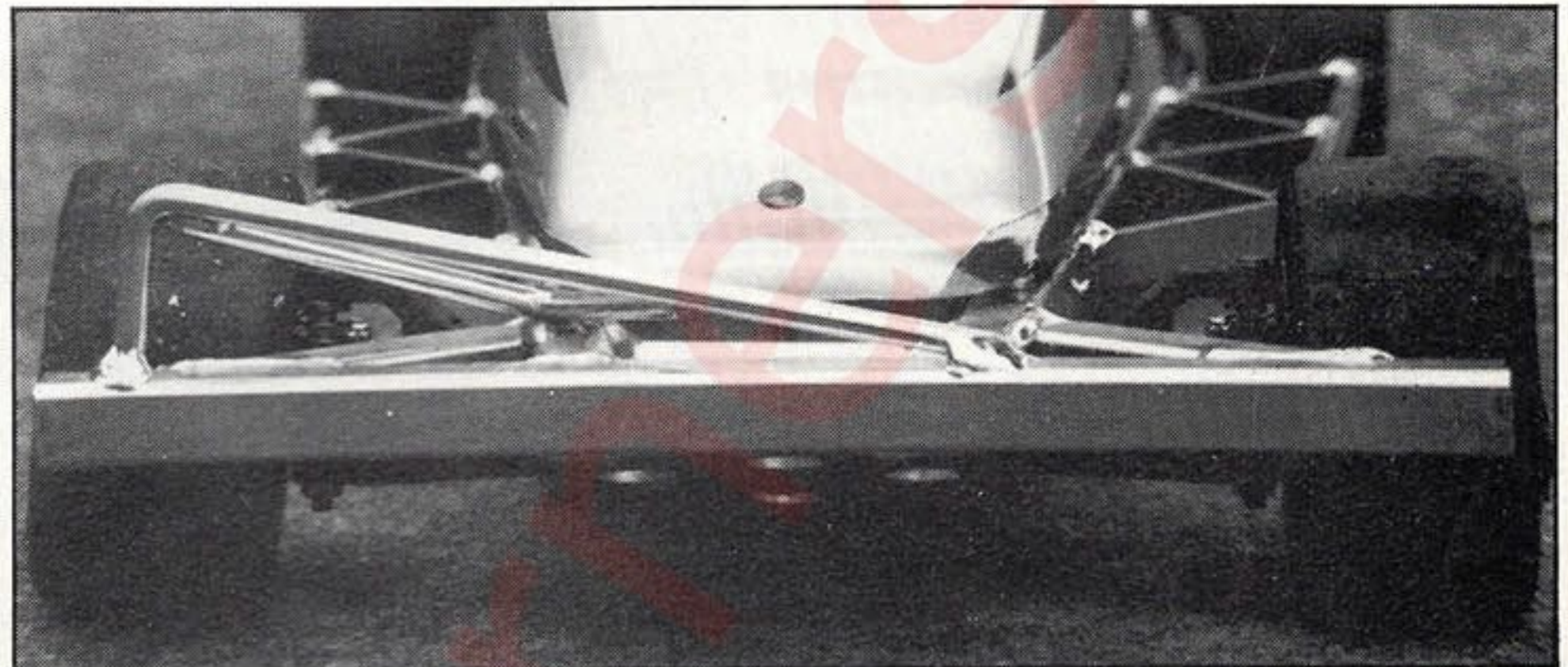

Above: you can see from this picture the camber on the right wheel (left of picture) this helps keep a larger proportion of the tyre's contact patch in touch with the circuit under cornering.

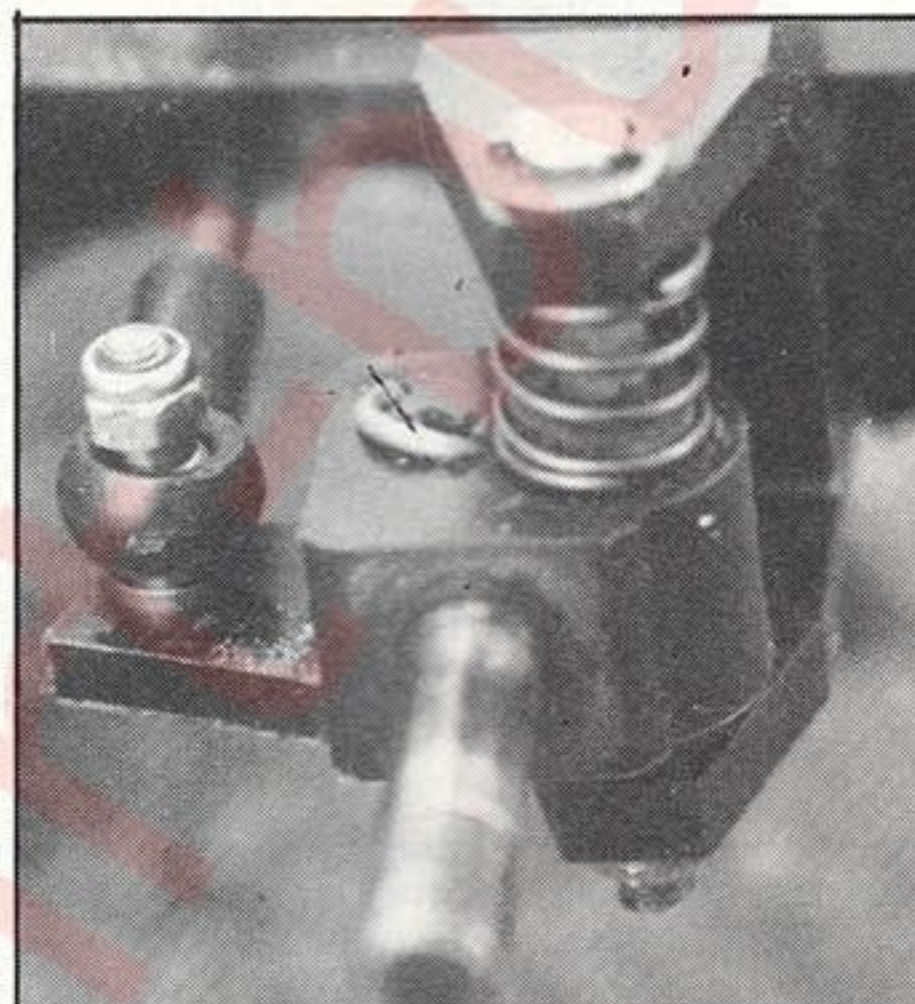

Above: After adding a little camber to the right front stub axle, the axle and the steering arm was drilled and pinned to prevent the axle rotating.

Left, by lightning the fly wheel the engine response was that much better, the weight loss was only slight in terms of overall weight but was significant when it came to acceleration.

The standard chassis has a good strong design like this rear bumper which has the extra 1/2in. square section to ward off the rear attack, no lightning work was carried out at this point on the middle and front cross members.

With a new chassis it is advisable to mark out the areas where the servo saver and throttle servo are to be mounted also where the radio crate is to be fitted before machine gunning the floor pan. Drilling the floor pan can be more accurate than the old Thompson! If you can use a stand drill then pretty patterns can be made whilst weight is reduced.

**The Front End**

With the chassis floor pan resembling a piece of cheese it was time to pay attention to the front of the car with all that standard equipment just crying for that little tweeking that is done by so many but not readily talked about until you mention what you have done, then you find to your ammazement that everyone else has been up to it for years. To what I refer is the castor angle, spindle trail, kingpin inclination and last but not least camber, now don't start reading Market Place or looking at the lovely pictures on the next page, it is really a simple job to incorporate all this steering geometry into your stock car, or in this case my stock car without costing a penny, in

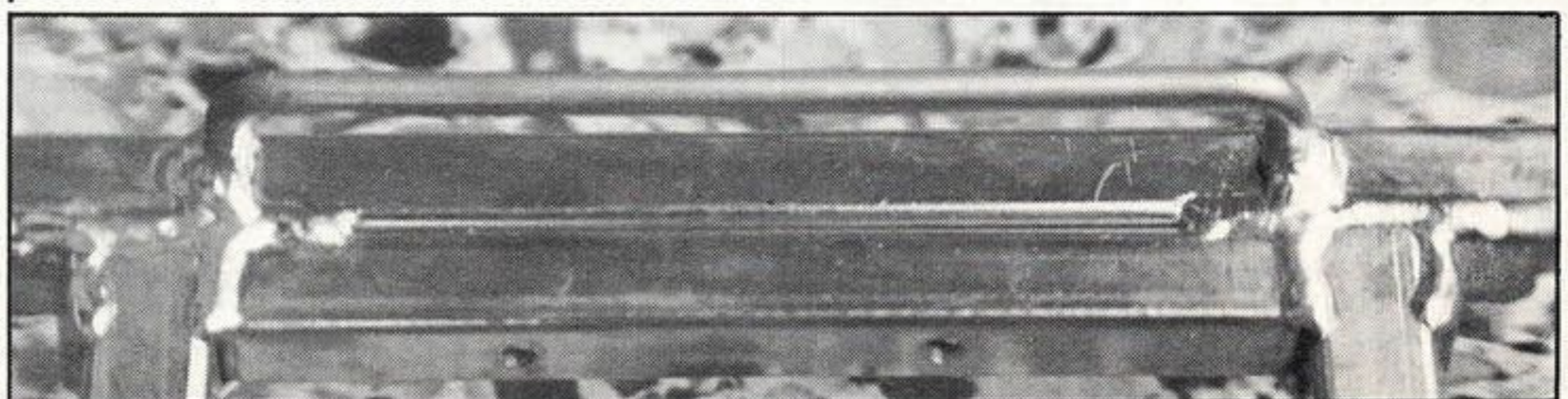
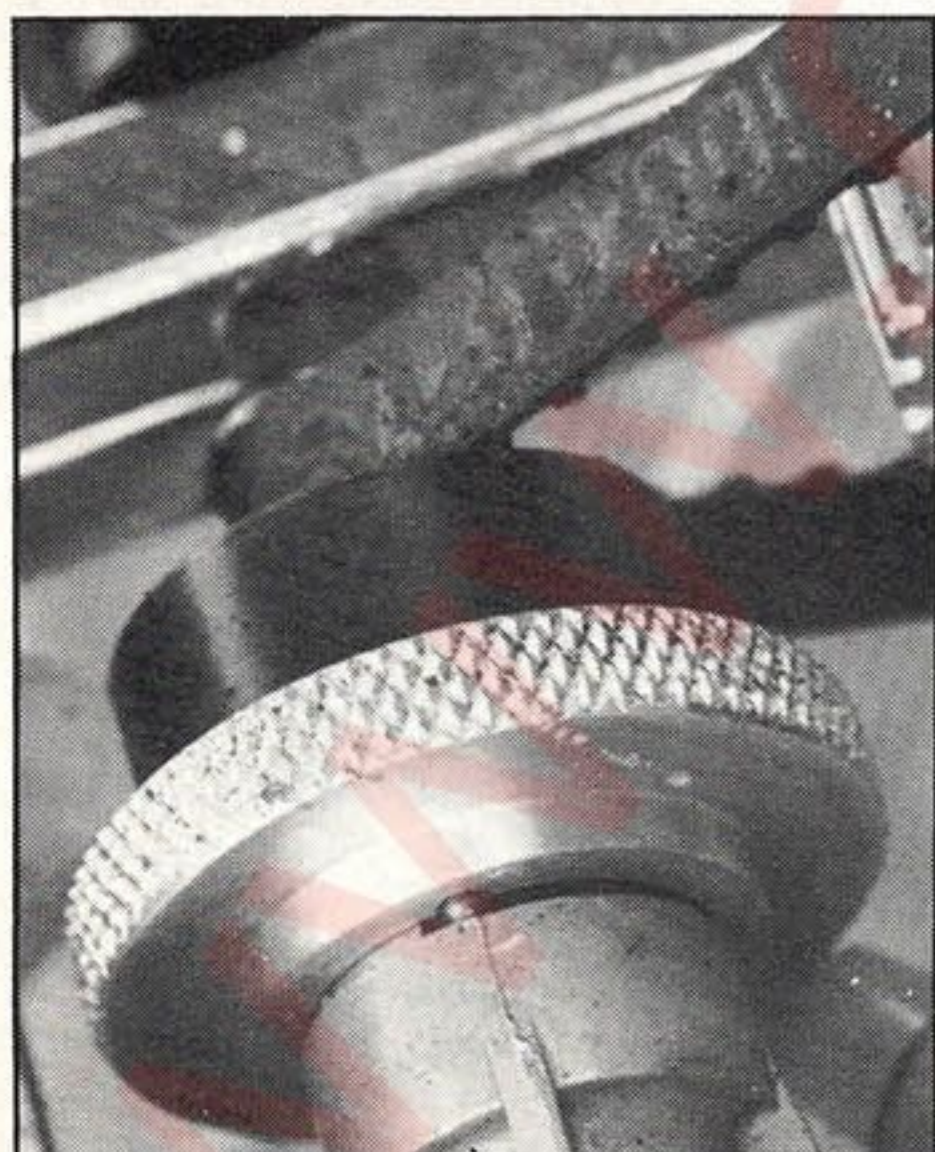

fact you would be hard pressed to go out and buy the set up off the shelf.

The purpose behind steering geometry is to give better road holding and more precise control of the car, this also gives even tyre wear to the front tyres, the standard set up allows the wheel to ride on the outer edge when cornering, making the tyre wear cone like, this can be very noticeable, on some cars it also reduces grip just when you need it.

Starting with the standard beam axle, the first operation to achieve my perfect steering geometry was to introduce a little lean on the front beam, to incline the kingpins about seven degrees (see diagram one) the effect of this is that, when you turn the car the kingpins being reclined will slightly lift the front wheel so that the roll of the car induced by cornering will push the tyre flat to the circuit giving more contact.

To do this with the standard beam axle is quite simple, by introducing wedges to the top of the beam before bolting to the chassis you effectively incline the kingpins, at the same time to work in conjunction with the kingpin inclination I added just a touch of camber to the right front wheel, the permanent left hand turns of the stock car oval only warrant work on the right stub axle.

There are different ways to camber the front wheels or in my case wheel, you can either angle the kingpin by purchasing from Mardave a undrilled beam axle, then

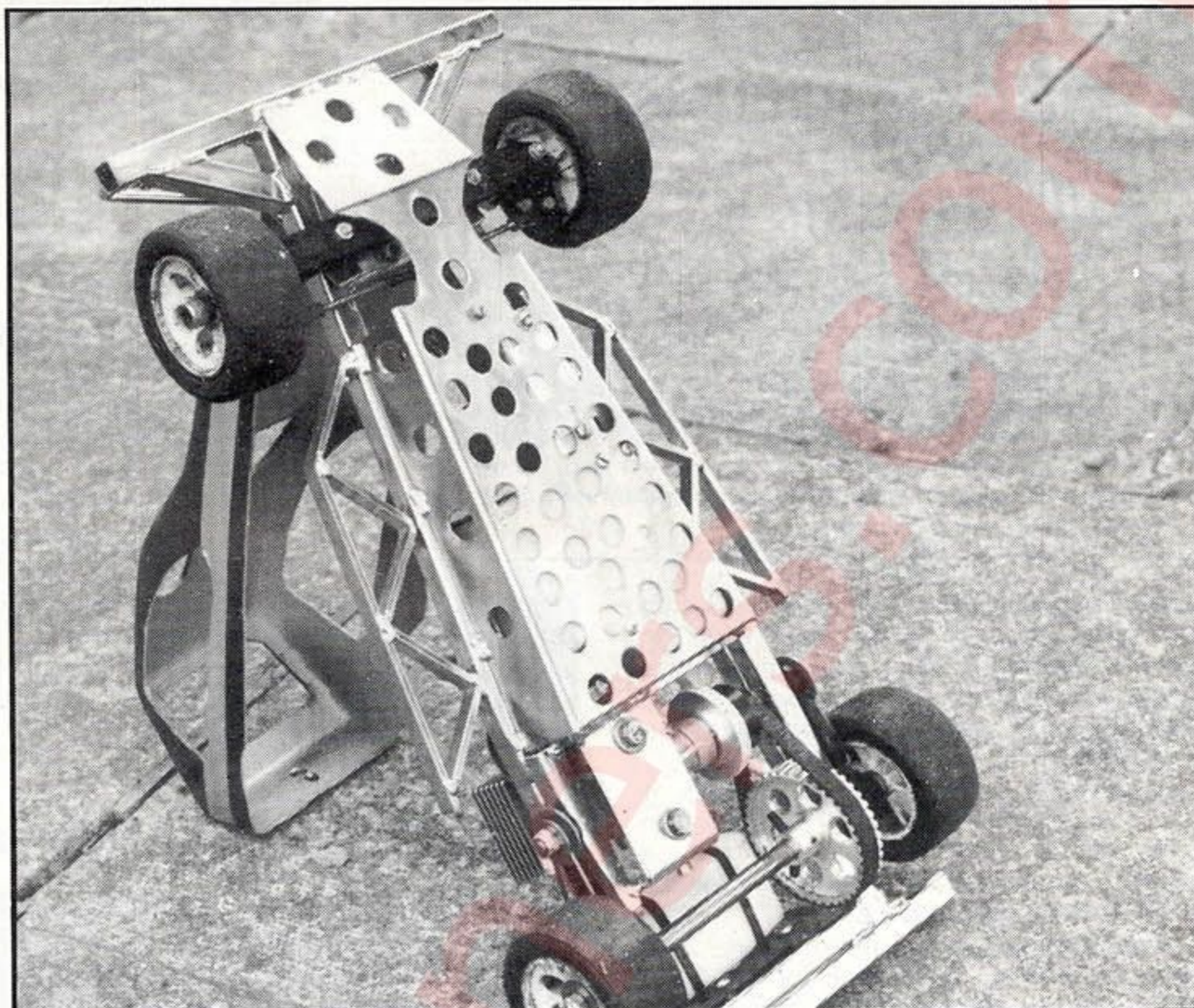

As you can see the machine gun came in handy but the stand drill was a lot more accurate, only the floor pan was given the treatment, but this was enough to lose a good 1/2lb.

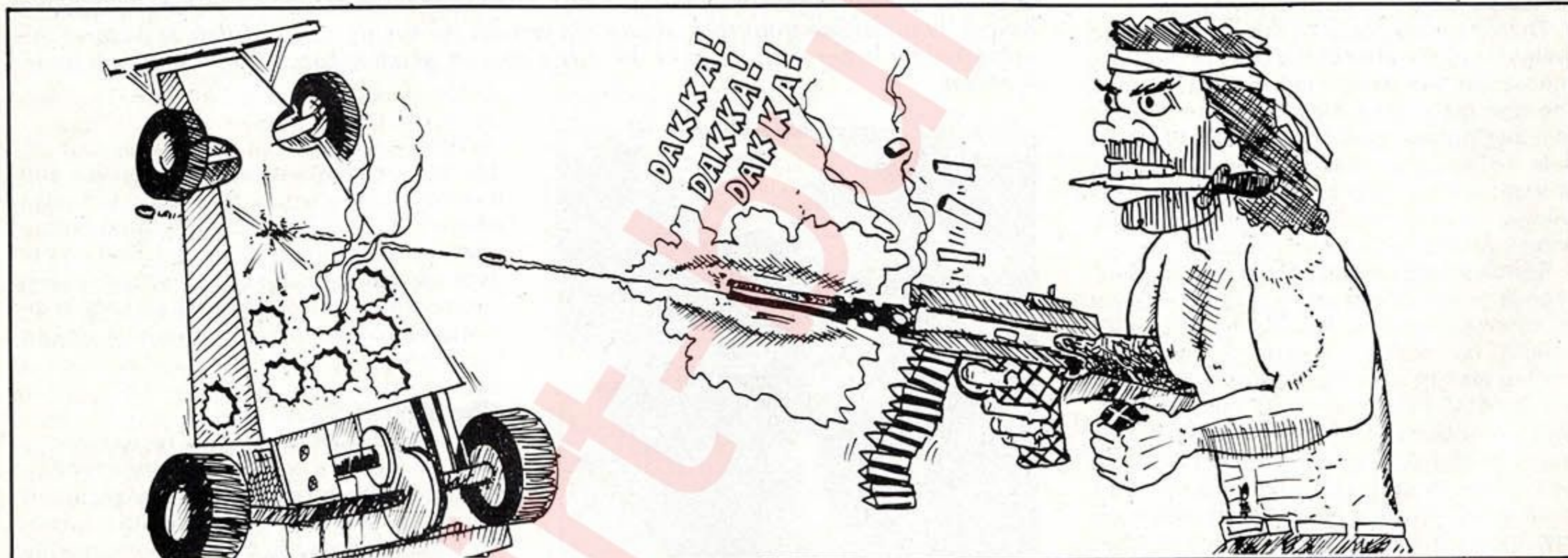

Below: By using two large washers on the rear suspension you can create a vice grip which will allow the springs to be easily set to suit the race conditions.

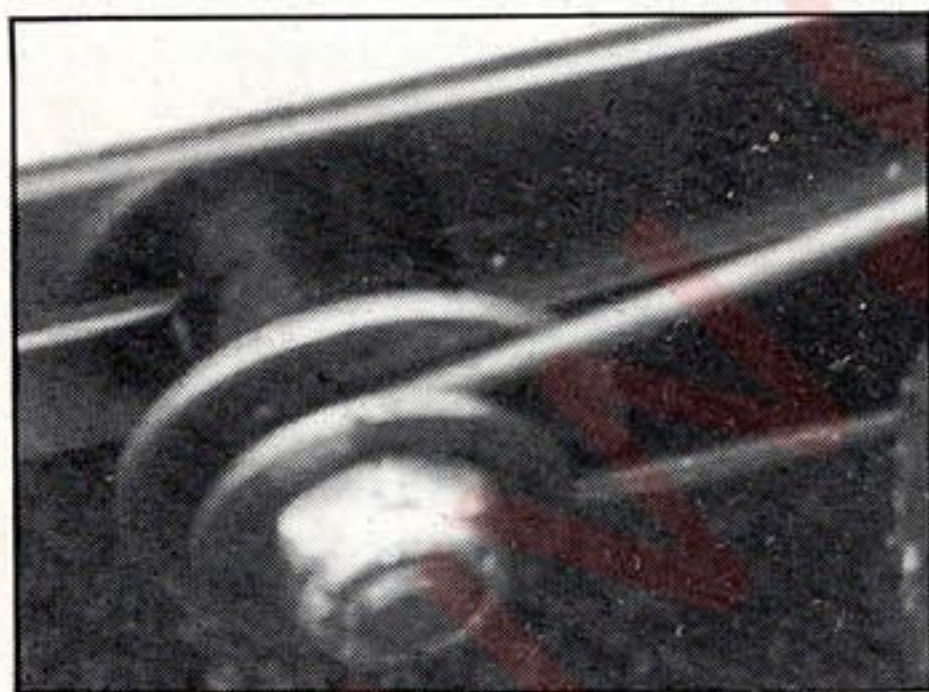

drilling for the kingpins at a slight angle, or as I chose because simplicity, to actually bend the stub axle (see diagram two) this has to be carried out with a little care, the angle you want must be about five to ten degrees maximum, the bend should be made as near the plastic moulding as possible, when this has been carried out re-

place the stub axle in the plastic steering arm, drill and peg to prevent movement.

As for spindle trail and castor the design of the Mardave stub axle already takes this into account.

With the front beam in place the servo saver was fitted, this was done so that the track rods when fitted to the servo saver would sweep backwards slightly to create better Ackerman steering (see diagram three). With new ball joints on the steering arms and the servo saver the play that had plagued the previous car was almost eliminated, as for the connection between the steering arms and the servo saver, a little play in this area can be of advantage as the steering servo will never return accurately to dead centre every time, but the steering under power down the straight has the tendency to write itself if a little play is present, but I do mean a little play not a school yard full.

#### The Rear End

Back to the rear end of the car for the next piece of construction. New radius arms,

springs, rear pulley, axle and Nyloc nuts were all deemed necessary to combat the problems with the previous car, of course you can change the items at any time you don't have to do the re-build that I have, in fact a little more routine maintenance would have saved me time and expense.

The standard rear hair grip suspension works well as it is, it works better if the standard springs re softened with a slight grip of the pliers, two large washers, one either side of the spring will act as a vice, when adjusted with the Nyloc nut this will enable the suspension to be adjusted to suit the circuit which you are to race.

I chose aluminium rear pulley because of the accuracy of a machined pulley compared to that of the plastic moulded type from Mardave, the life expectancy is also much greater, much in my mind more than compensates for the higher price.

The rest of the car remains standard as was the original, the new car weighs 6 3/4 lbs., which is over 1/2 lb., lighter than the original, the performance is good but how it stands the test of time, only time will tell.



# MALVERN MODELS

SPECIALISTS IN RADIO CONTROL MODEL AIRCRAFT BOATS AND CARS

31 Pump Street, Worcester WR1 2QX

Tel: 0905 24127/29318

## OFF ROAD CARS AND DEALS

Car	Pack A with Slow Charger	Pack B with Fast Charger
Grasshopper .....	39.95	108.95
Hornet .....	48.95	121.95
Striker .....	53.95	123.95
Falcon .....	58.95	129.95
Boomerang .....	83.95	151.95
Hotshot 2 .....	98.50	169.95
Bigwig 7.2v .....	139.95	208.95
Bigwig 8.4v .....	139.95	222.95
Porsche 959 .....	122.95	194.95
Optima .....	109.99	174.95
Blackfoot .....	74.95	142.95
Lunch Box .....	62.95	132.95
Monster Beetle .....	79.95	149.95
Ultima .....	95.95	167.95
Cosmo .....	59.95	131.50
Schumacher Cat .....	P.O.A.	P.O.A.

All these deals include Futaba BEC Radio (subject to availability). Free building service available on all packages.

For all your buggy requirements give us a call.  
Postage: Kits £2. Packages £2.50 + 50p insurance on both

## BATTERIES

Sanyo 7.2v SC .....	15.95
Sanyo 7.2v SCR Selected .....	21.95

## RADIOS

Futaba Attack BEC .....	43.95
Acoms Techniplus BEC .....	45.95
Acoms Technidrive .....	41.95
Futaba 2LGX .....	P.O.A.
Futaba 3EGX .....	P.O.A.
Sanwa Dash .....	41.95

We also stock a comprehensive range of motors and accessories by: Demon, Parma, Kyosho, Schumacher, PB, Brimod, Tamiya, SRM, RS Components, Pactra Paints, Futaba, Acoms, Sanwa, TMS, MFA, plus many more.

- \* If you want to buy it then we probably stock it
- \* Mail Order is our pleasure with same day despatch.

Please note all prices are correct at time of printing and we retain the right to alter prices at any time.

# NOSRAM THE POWER PACKAGE

DISTRIBUTED BY MALVERN MODELS

NOSRAM ADVANCED FET CONTROLLER	NOSRAM CHARGER	NOSRAM HIGH ENERGY CELLS	MG MOTORS
<b>FEATURES:</b> <ul style="list-style-type: none"> <li>* 8 High Spec FETs</li> <li>* Fully proportional forward brake &amp; reverse</li> <li>* Forward only facility</li> <li>* FET brake and reverse</li> <li>* Voltage Multiplying circuitry for increased FET efficiency</li> <li>* Independent rate adjustment for both forward/reverse and brake</li> <li>* Electrical interlock circuitry for FET protection under fault conditions</li> <li>* Thermal override on brake/reverse</li> </ul> Size 65mm x 35mm x 27mm Weight 55grms (approx) Price £67.95	<b>Latest Mosfet Technology</b> <b>FEATURES:</b> <ul style="list-style-type: none"> <li>* Constant Current</li> <li>* Thermal sensine</li> <li>* Auto cut off when cell temperature increases by 10°C</li> <li>* Manual selection of cut off temperature</li> <li>* Protection against inverse polarity of 1.2v battery</li> <li>* Protection against nicad output being shorted</li> <li>* Protection against nicads being inversely connected</li> <li>* Automatic cut off if the thermal sensor becomes disconnected from charge</li> </ul> £45.00	<b>Latest in Computer Matched SCRs</b> <b>FEATURES:</b> <ul style="list-style-type: none"> <li>* Computer matched</li> <li>* High energy</li> <li>* Back up library of cells to keep your packs in top condition</li> </ul> Price £29.95	Magnum Full Modified 15T - 16T - 17T Quad ..... £39.95 15T - 16T - 17T Triple ..... £39.95 * * * * * Red Dot + 17T Double ..... £25.95 18T Single ..... £25.95 19T Double ..... £25.95 27T Single ..... £25.95

**Trade Enquiries now welcome**

**Distributed by:  
Malvern Models  
31 Pump Street  
Worcester  
WR1 2QX  
Tel: 0905/29318  
24127**

## TEAM M.G.N. DRIVERS

MIKE BRIDGES                      STEVE HAYNES  
NEIL STRINGFELLOW

### Results

1st	SRM Challenge — Stafford	Mike Bridges
1st	BRCA — Woodvale	Mike Bridges
1st	FTD + Track Record — Ever Ready International — Southend	Mike Bridges
1st	Eastnor Model Spectacular	Mark Mainey
1st	Swords — Weston-super-Mare	Simon Evans

ALL USING THE NOSRAM POWER PACKAGE

## NOSRAM STOCKISTS

M.G. Models Products  
 Otley Modelsport  
 Phil Booth Models  
 Northern Model Centre  
 Trapnells Model Shop  
 C. Sawyers Model Shop  
 Morley Models  
 Model Box  
 JDM  
 Penn Models

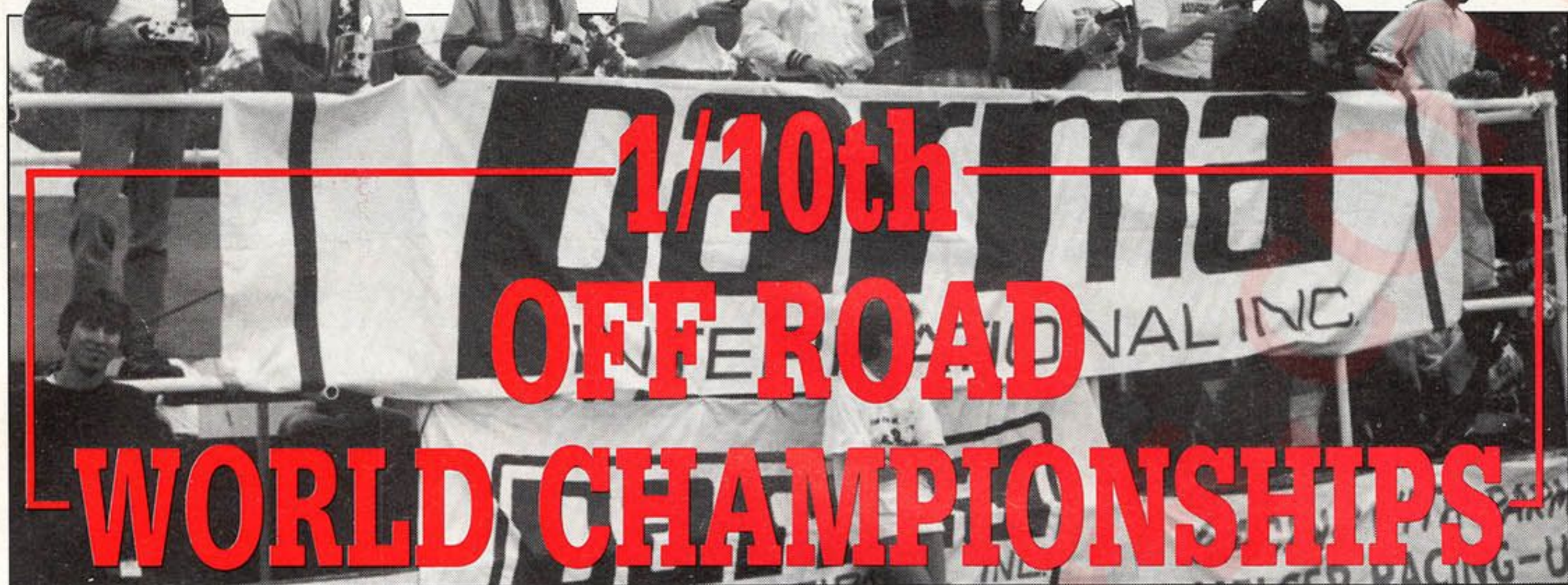

R.R.C. reports from the second 1/10 World Championships

Drivers from all over the world gathered at Romsey to fight for two crowns, the 1/10 2wd championship and the 1/10 4wd championship. It was to be six days of the hardest, closest racing ever, at the end of it all just two drivers of the original two hundred and forty could call themselves the best in the world.

**Monday, Practice. 2WD**

As anyone who has visited the Romsey circuit would know, the surface is probably the hardest there is to find grip on, which is why it seemed such a good idea to hold an international meeting there earlier in the year. This would allow some drivers the opportunity of testing for the worlds or so they thought. However, Bill Jones, the event organiser had other ideas, he had completely changed the tracks surface, gone was the red speedway shale, in its place was hard packed earth with a light dusting of grit. As one American team member put it "There may be just one track with less bite, on the moon!"

Practice day then was an eye opener to everyone, as combinations of suspension settings, tyres, motors and tempers were tried, all it seemed to no avail. By midday no-one was happy, there just wasn't enough grip. There were some weird and wonderful attempts at adding, re-distributing or directing weight to the rear tyres of some cars, at this point names are best kept out but certain cars were seen with screwdrivers taped inside them, batteries split into two packs of three and one pack hung right out under the motor, someone was even running a selection of ideas, including five pound coins inside the chassis, oh well it takes all sorts! One thing was certain though and that was this was no track for novices, even under those dry dusty conditions drivers were showing their skill as cars were jumping from lock to lock and trying to spin out on the straight.

**Tuesday, A Breakthrough**

Tuesday morning saw the beginning of timed heats and still the grip problem existed. In the public area was the track shop, supplied by S.R.M. never have so many drivers been in the same place at one time and all discussing just what it was that was needed, by now things out on the track had gone from the sublime to the ridiculous and the driver of one car had glued two front tyres to the rear wheels of his car to

see if that would help! Then a breakthrough occurred and it was found that Kyosho dimple block soft tyres were giving all the grip you needed, nice one Option House. From there on there was no holding back and laps and times improved drastically. By the end of Tuesday's practice session the mist was beginning to clear, sixteen laps were needed and the Kyosho Ultima was showing a clean pair of wheels to just about everything in sight.

There were of course one or two exceptions to this, Rory Cull was going very well with his RC10 and Eustace Moore with his own M.I.P. RC10, Eustace must have been the unluckiest man on the track, if there was a pile up, he was in it, not once did he cause it, but he was on the bottom of the pile everytime, if he could have got one clean run, who knows, there was one more round of practice to go and everything still to race for.

**Wednesday, The Final Conflict**

Wednesday dawned bright and early for most, the weather was still dry and sunny, the track showed no signs of wear and tear but still offered little grip, the final round of practice took place and the finals were decided A finalists were (in no particular order) Eustace Moore, Masami Hirotsuka, Kris Moore, Rory Cull, Jay Halsey, Katsunori Kondo, Jamie Booth, Mike Christensen, Kevin Moore and Joel Johnson. These were the drivers who so far had gone faster than anyone else, one of them would be World Champion by the end of the day.

As the finals got underway tension mounted until the drivers mounted the rostrum for the first of the three heat A finals. Drivers were given the ten second warning and then they were off, the head-long dash to the first corner resulted in the usual carnage, once more Eustace Moore was on the bottom, his luck was holding. Away from the pile up first, was Joel Johnson driving his Ultima followed by Kris Moore's Ultima and Jamie Booths RC10. The similarities between these two cars are such that once drivers of this class get an edge, it is difficult to get it back. Having said that all three drivers drove a faultless race and the first A final heat finished the way it began. After the heat Rory Cull was awarded a ten second penalty for jumping the start.

Heat 1		
Name	Laps	Time
1 Joel Johnson	16	318.5
2 Kris Moore	16	319.96
3 Jamie Booth	15	301.7
4 Mike Christensen	15	302.36
5 Katsunori Kondo	15	306.15
6 Rory Cull	15	322.5
7 Jay Halsey	14	301.83
8 Kevin Moore	14	302.2
9 Eustace Moore	14	303.05
10 Masami Hirotsuka	9	196.85

Heat two saw a clean start and a change of pace, everyone seemed to be going slower, which as it turned out they were, no one turned in the magic sixteen laps of the first heat. However some exciting racing was to be seen as Jamie Booth moved up through the field giving a text book display of driving in traffic, always patient Jamie drive from sixth place to finish a great second. Mike Christensen was always too far away though, driving smoothly and making no mistakes he finished four seconds ahead of a charging Jamie Booth.

Heat 2		
Name	Laps	Time
1 Mike Christensen	15	300.18
2 Jamie Booth	15	303.78
3 Katsunori Kondo	15	305.23
4 Kevin Moore	15	311.7
5 Joel Johnson	15	312.63
6 Jay Halsey	15	315.13
7 Rory Cull	15	316.83
8 Eustace Moore	15	318.46
9 Masami Hirotsuka	15	323.51
10 Kris Moore	5	108.95

Heat three started and it was still anybody's race, Katsunori Kondo took an early lead and was flying. Barring accidents the race was his, could he make that magic seventeen laps that would put the World Champions crown on his head? Meanwhile the race developed between Masami Hirotsuka, Joel Johnson and Kris Moore, around the four minute mark the race order sorted itself out and the U.S.A. knew they had a World Champion as Joel Johnson moved into second place behind Kondo. With each passing lap every American racer cheered louder as the two cars from the U.S.A. passed where they stood until the five minutes were up, the first three over the line were Katsunori Kondo, Joel Johnson and Kris Moore!

4WD, the best three drivers in the world.



Above, the best 2WD class drivers in the world.

Right, all that was missing was Murray Walker's commentary, well maybe not!

Below, to the victor, the laurels. Hiro's C.A.T.

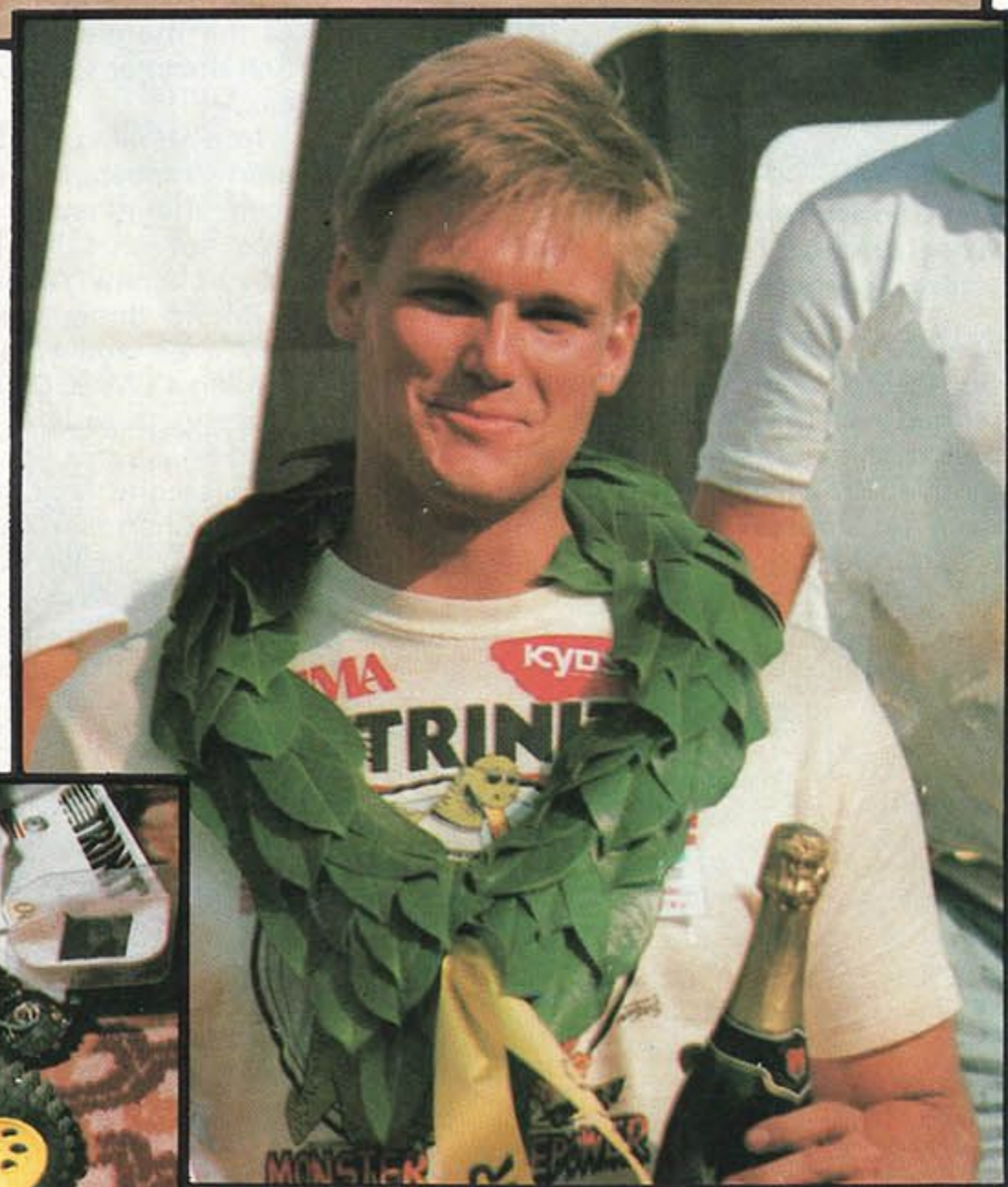
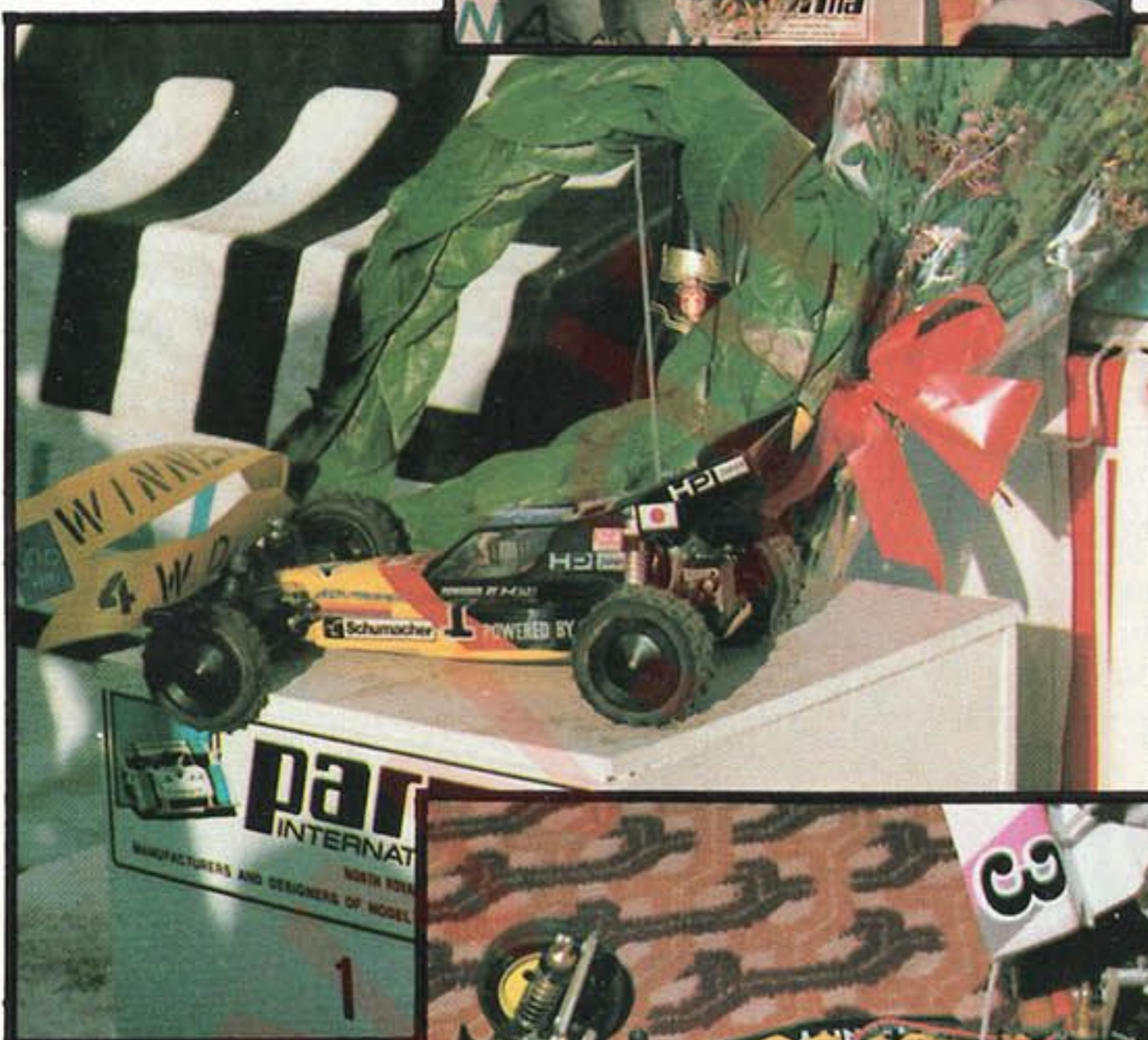

Joel Johnson's superb Ultima, could this be the car to better the RC107

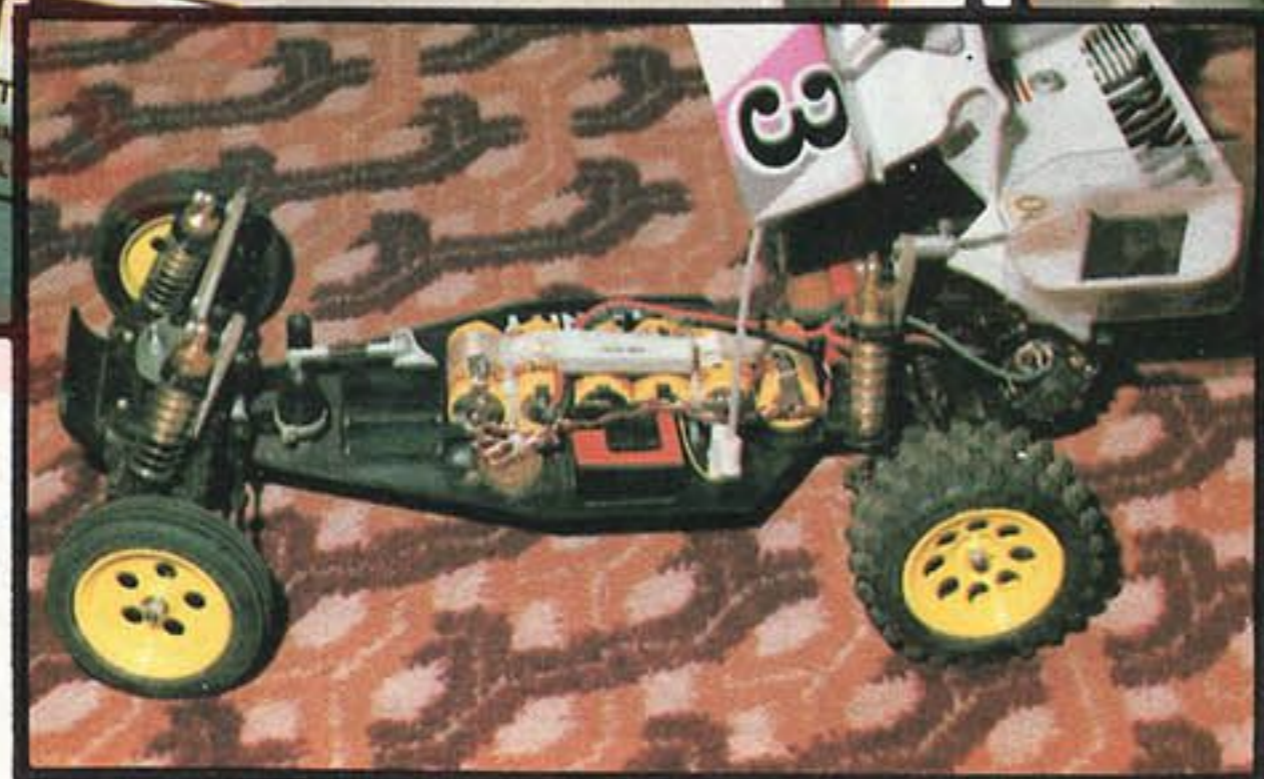

All smiles now the heat is off, Joel Johnson the new 2WD World Champion.

Heat 3		
Name	Laps	Time
1 Katsunori Kondo	16	318.98
2 Joel Johnson	15	300.3
3 Masami Hirosaka	15	304.83
4 Kris Moore	15	307.75
5 Jay Halsey	15	310.38
6 Kevin Moore	15	312.66
7 Eustace Moore	15	314.98
8 Rory Cull	15	316.6
9 Mike Christensen	15	318.7
10 Jamie Booth	1	19.666

The final positions were as follows:-

1 Joel Johnson	U.S.A.	Kyosho Ultima
2 Katsunori Kondo	Japan	Kyosho Ultima
3 Kris Moore	U.S.A.	Kyosho Ultima
4 Mike Christensen	U.S.A.	M.I.P. RC10
5 Jamie Booth	U.K.	RC10
6 Kevin Moore	U.S.A.	RC10
7 Jay Halsey	U.S.A.	Yokomo
8 Masami Hirosaka	Japan	Kyosho Ultima
9 Rory Cull	U.K.	RC10
10 Eustace Moore	U.S.A.	M.I.P. RC10



The German front wheel drive C.A.T. Front wheel drive cars are now banned from 2wd classes, see editorial!

**If Only We'd Have Dept?**

So the U.S.A. and Joel Johnson in particular had won the 2WD World Championship and won a deserved victory. More importantly the relatively new Ultima and proved itself an unbreakable mount and broken the long held dominance of the legendary RC10. What happened to Jamie we hear you ask? Well, the Romsey curse struck Jamie again he was lying second after his

first lap when his car broke. Ah well there's always the 4wd to go.

**Friday, Practice 4WD**

As a fair percentage of drivers from the 2wd class were also competing in the 4wd, the lessons learnt were invaluable and practice centred mainly on trying to find out if the Kyosho Option House, dimple block tyre would suit the 4wd cars as well. It seemed they did. All eyes were on the new, mid engined, belt driven Kyosho Optima and the thought that everyone had and no one admitted, could Kyosho do the double?

During the mornings practice several cars were seen to be looking good the new Yokomo as yet unnamed, T.A.G.'s Coyote promised a fair showing and so did the new Mugen.

The first round of heats revealed the nature of how things were to be for the next two days, straightaway sixteen laps were posted, it seemed as if those who had raced 2wd had passed the word around and cars were flying around the slippery Romsey track.

Friday ended with an insight into how things were to finish, Katsunori Kondo and Masami Hirosaka had both smashed the track record, turning seventeen laps each, Kondo with a six week old prototype and Hirosaka with a short wheelbase C.A.T. now there's a thing!

**Saturday, Some Things Just Don't Change.**

Again the sun shone and the weather stayed hot and dry, the track was staying in remarkably good shape considering the amount of racing that had taken place on it, all thanks to the hard work of the Romsey club members and the amazing track make up. Racing was again fast and furious with amazing skill being shown by all drivers. Sixteen laps were being turned in by driver after driver and then during the first round of the morning Cliff Lett driving a L.W.B Schumacher CAT joined the seventeen lap club.

In a thrilling heat in which he led from start to finish, his lap times were all eighteen and nineteen seconds. Glyn Peglar was hot on Cliffs heels and Gary Keyes driving a new Yokomo was third.

Round three, the second round of the day once again saw Hirosaka, this time driving a L.W.B. CAT put in another scorching seventeen laps and break the track record again, this time putting in two seventeen second laps. Where was the current World Champion Gil Losi Jr? He had put in a high sixteen lap run but seemed to be unhappy with his new Yokomo, or at least the front end, well rumour had it that Jr and Pops had been assembling the car on the

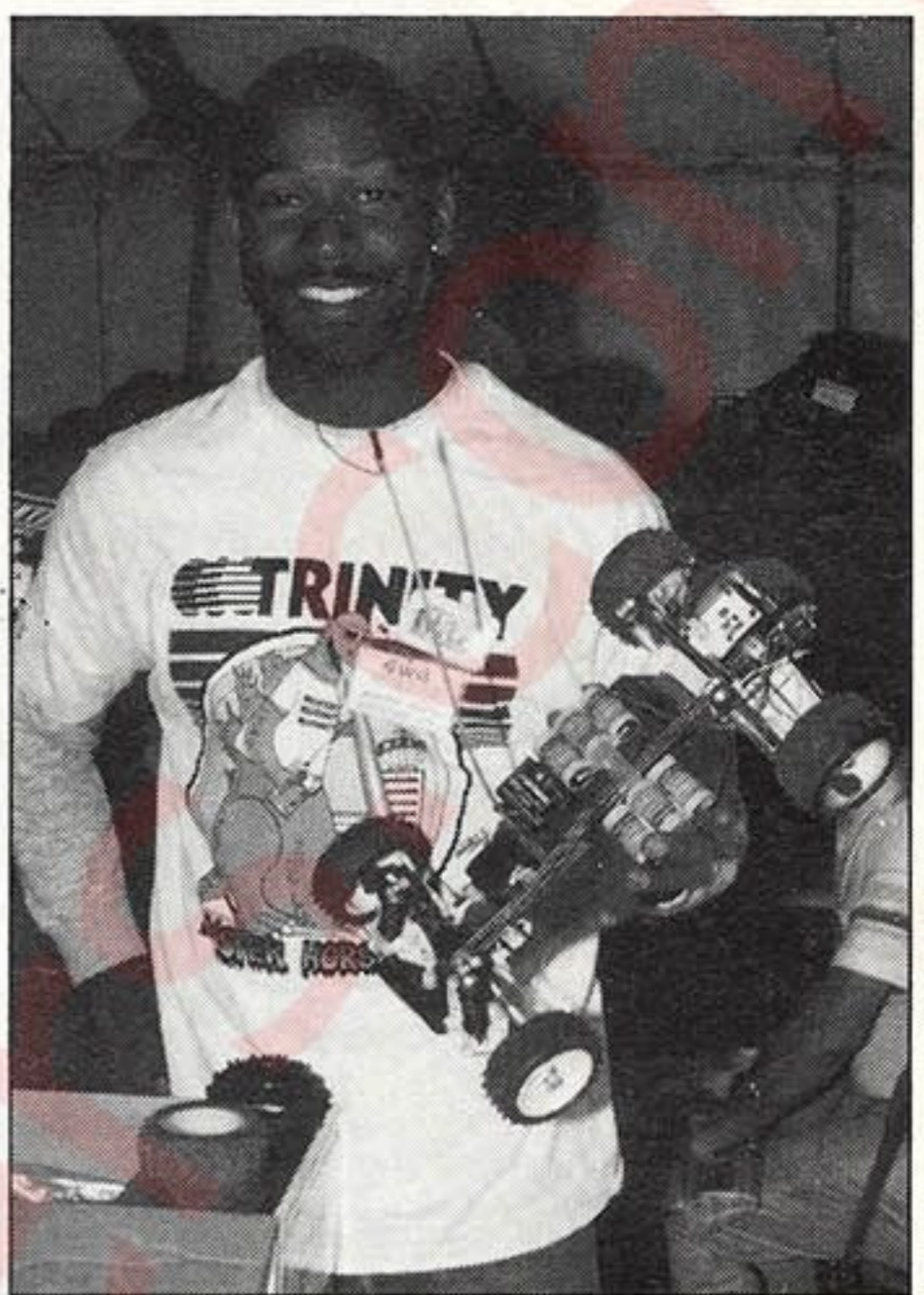

Eustace Moore, Mr. M.I.P. himself holds his RC10, 4wd conversion.

flight over to the U.K. That may not be strictly true but they were very new Yokomo's and when properly developed will be very lethal judging by the way Jay Halsey and Tony Neisinger were going.

Round four and a charging race by Joel Johnson put him straight into the top four with another seventeen lapper.

Jamie Booth had by this time taken some advice from Mike Reedy himself, and fitted his CAT with an awesome thirteen turn double wind motor that was eating brushes at the alarming rate of a new set every heat. However, this seemed to do the trick as he tucked his Cats nose under the wing of Joel's Optima and he also turned in a seventeen lapper.

The final round of the day saw Jay Halsey push his new Yokomo through the sixteen lap barrier into the seventeens, by the end of Saturday six drivers had all put up seventeen laps and were sure of an A final place.

**Sunday, The Best View Is From The Rostrum**

Sunday morning gave one last chance to reach the A finals. By 9 o' clock the trackside was packed with spectators and the atmosphere was electric as every driver gave it one last go and drove their best race trying to reach the A final, the mornings racing was terrific with some brilliant displays by Pete Stevens, Junichi Koma and Eric Sodaquist all driving new Optimas. Mike Christensen was the last to qualifying into the A final with his M.I.P. 4wd RC10. Once again and with almost boring regularity Hirosaka turned in another brilliant seventeen lapper.

So the stage was set, all finals had been sorted out and the top ten qualifiers were as follows:-

1 Masami Hirosaka	Japan	LWB CAT
2 Joel Johnson	USA	Optima Mid
3 Jay Halsey	USA	New Yokomo
4 Katsunori Kondo	Japan	Optima Mid
5 Jamie Booth	UK	LWB CAT
6 Cliff Lett	USA	LWB CAT
7 Pete Stevens	UK	Optima Mid
8 Junichi Koma	Japan	Optima Mid
9 Eric Sodaquist	USA	Optima Mid
10 Mike Christensen	USA	RC10 M.I.P

Name	Car	Motor	Batteries	Speed Controller	Shocks	Diff F	Diff R	Nationality
Mike Christensen	M.I.P. RC10	Trinity	Sanyo SCR	Trinity	Kyosho	Ball	Ball	U.S.A.
Junichi Koma	Mid Engined Optima	Peak Performance	Sanyo SCR	Sanwa Vortex	Kyosho	Ball	Ball	Japan
Jay Halsey	Yokomo	Reedy	Sanyo SC	Novak	Yokomo	Ball	Ball	U.S.A.
Katsunori Kondo	Mid Engined Optima	Kyosho Le Mans	Sanyo SCR	Futaba	Kyosho	Ball	Ball	Japan
Masami Hirosaka	C.A.T.	H.P.I. Uno	Sanyo SCR	K.O. CX1	Schumacher	Ball	Ball	Japan
Joel Johnson	Mid Engined Optima	Trinity	Sanyo SCR	Tekin	Kyosho	Ball	Ball	U.S.A.
Jamie Booth	C.A.T.	Reedy	Sanyo SC	Futaba	Front C.A.T. Rear RC10	Ball	Ball	U.K.
Cliff Lett	C.A.T.	Reedy	Sanyo SCR	Novak	Associated	Ball	Ball	U.S.A.
Pete Stevens	Mid Engined Optima	Parma	Parma	Laser	Kyosho	Ball	Ball	U.K.
Eric Sodaquist	Mid Engined Optima	Twister	Sanyo SC	Sanwa	Kyosho Option House	Ball	Ball	U.S.A.

Once again the stage was set, the battle was between ten drivers and four manufacturers Kyosho, Yokomo, Associated and Schumacher, who was going to win, which car would take the World Championship, which driver would be World Champion?

At last the finals were underway and the first leg of the A final saw some amazing line techniques being employed, Ernie Provetti, Mr Trinity himself was using a small 12 volt battery and charger to keep Johnsons batteries topped well up until the very last second. Unbelievably some drivers were having duration problems or had this World Championships really exposed the great divide in battery capacity? Which brings on further questions, see the editorial!

The first round was underway and Hirosaka went straight into the lead from his pole position, he was using standard SC cells and a motor that was unbelievably quick, made by H.P.I. and called the Uno, it is believed that they will shortly be available in the U.K. let's hope so. Jamie Booth was also putting in a flyer, by now he and Mike Reedy had got it right, Jamie was happy with his 15 turn double wind and put in two seventeen laps to finish second. Jay Halsey and Eric Sodaquist were having a rare old battle, eventually Eric Beat Jay into third place by a narrow margin.

**'A' Final 1st Leg**

Name	Laps	Time
1 Masami Hirosaka	17	314.63
2 Jamie Booth	16	301.3
3 Eric Soderquist	16	307.99
4 Jay Halsey	16	309.49
5 Joel Johnson	16	309.61
6 Pete Stevens	16	312.9
7 Cliff Lett	16	321.93
8 Katsunori Kondo	15	286.76
9 Mike Christensen	15	301.43
10 Junichi Koma	15	304.66

Round two saw the pace slow slightly as Jamie Booth turned on the magic once again. Starting from sixth after a first bend fiasco involving just about every car, Jamie drove a brilliant race, diving inside cars then out accelerating others to finally pass the Schumacher C.A.T. of Cliff Lett. Cliff made life really difficult shutting the door on Jamie as often as he could but with Jamie in this form he couldn't hold him back for long, eventually Jamie slipped inside Cliff to take the second leg. Meanwhile Hirosaka who had been left with a more or less clear track has also been quietly clock-

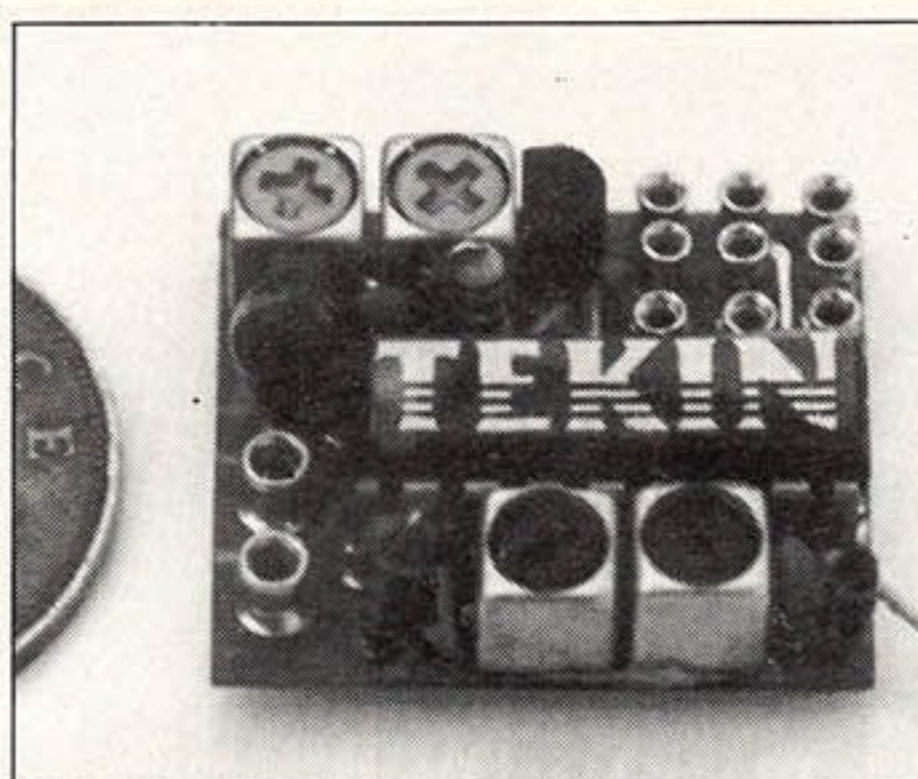

**No your eyes aren't playing tricks, this is Tekins soon to be released receiver!**

ing up laps and so had Kondo.

**'A' Final 2nd Leg**

Name	Laps	Time
1 Jamie Booth	16	301.41
2 Cliff Lett	16	303.43
3 Masami Hirosaka	16	306.56
4 Joel Johnson	16	308.53
5 Jay Halsey	16	310.46
6 Junichi Koma	16	311.18
7 Katsunori Kondo	16	317.23
8 Pete Stevens	16	317.68
9 Eric Soderquist	15	295.13
10 Mike Christensen	10	214.63

Round three and again a bad start around bend one saw Katsunori Kondo way out in front, the battle for second place was between Hirosaka, Cliff Lett and Jamie Booth. Hirosaka took the clever way out and went for a clean drive, leaving Jamie and Cliff to battle it out once more, this time Cliff kept some distance between himself and Jamie and drove a great race concentrating all the way. Jamie tried but just couldn't catch Cliff eventually round three saw the finish Kondo, Lett, Booth.

**'A' Final 3rd Leg**

Name	Laps	Time
1 Katsunori Kondo	17	318.88
2 Cliff Lett	16	301.93
3 Masami Hirosaka	16	304.25
4 Jamie Booth	16	310.13
5 Junichi Koma	16	310.93
6 Joel Johnson	16	316.83
7 Pete Stevens	16	321
8 Jay Halsey	5	94.033
9 Mike Christensen	4	86.45
10 Eric Soderquist	0	0

This gave the 4wd World Championship crown to Masami Hirosaka of Japan,

Katsunori Kondo also of Japan was second and Jamie Booth U.K. was third.

**All Over Bar The Shouting**

So where do we start to sum up, first congratulations are in order to Katsunori Kondo and his team for a marvellous victory. Cecil Schumacher and his team must also be included, now they can say with absolute certainty, what some of us knew all along, that they do manufacture the number one car in the world! Kyosho are definitely on a winner with their new mid engined, belt driven Optima after only six weeks prototype racing to get five in the A Final is remarkable, Yokomos as yet unnamed 4wd car will also prove itself better than the dogfighter! Yes better just give it a little time.

There we have it until next time, the venue will be Hong Kong or Australia, let's hope we can cover that one too.

**Cars Taking Part 4WD**

- Optima 34
- Yokomo 16
- Cat 34
- Coyote Tag 4
- MIP RC10 3
- P.B. 11
- Mugen 2
- AYK 2
- Others (scratch or conversions) 4

**Winners of Other Finals**

- 4WD**
- Marco de Marchi — B
  - Steve Haynes — C
  - Nino Athanasiou — D
  - Klaus Wilhem — E
  - Andrew Bolton — F
  - Kris Moore — G
  - Stephan Oberle — H
  - Greg Collins — I
  - Robert Smith — J
  - Mark Luney — K
  - .... Spongia — L
- 2WD**
- Umberto Penice — B
  - Mike Giem — C
  - Stephan Kaske — D
  - Klaus Wilhelm — E
  - Peter Liu — F
  - Neil Stringfellow — G
  - Tony Neisinger — H
  - Tony Rossetti — I
  - Mark Ferguson — J
  - Keith Young — K
  - Meryn Bonte — L

**Both of these photographs show the neatest scratchbuilt car that competed, basically an Ultima, the power take off from rear to front was all made up using helicopter tail rotor gears power supplied by the now famous H.P.I. Uno motor.**

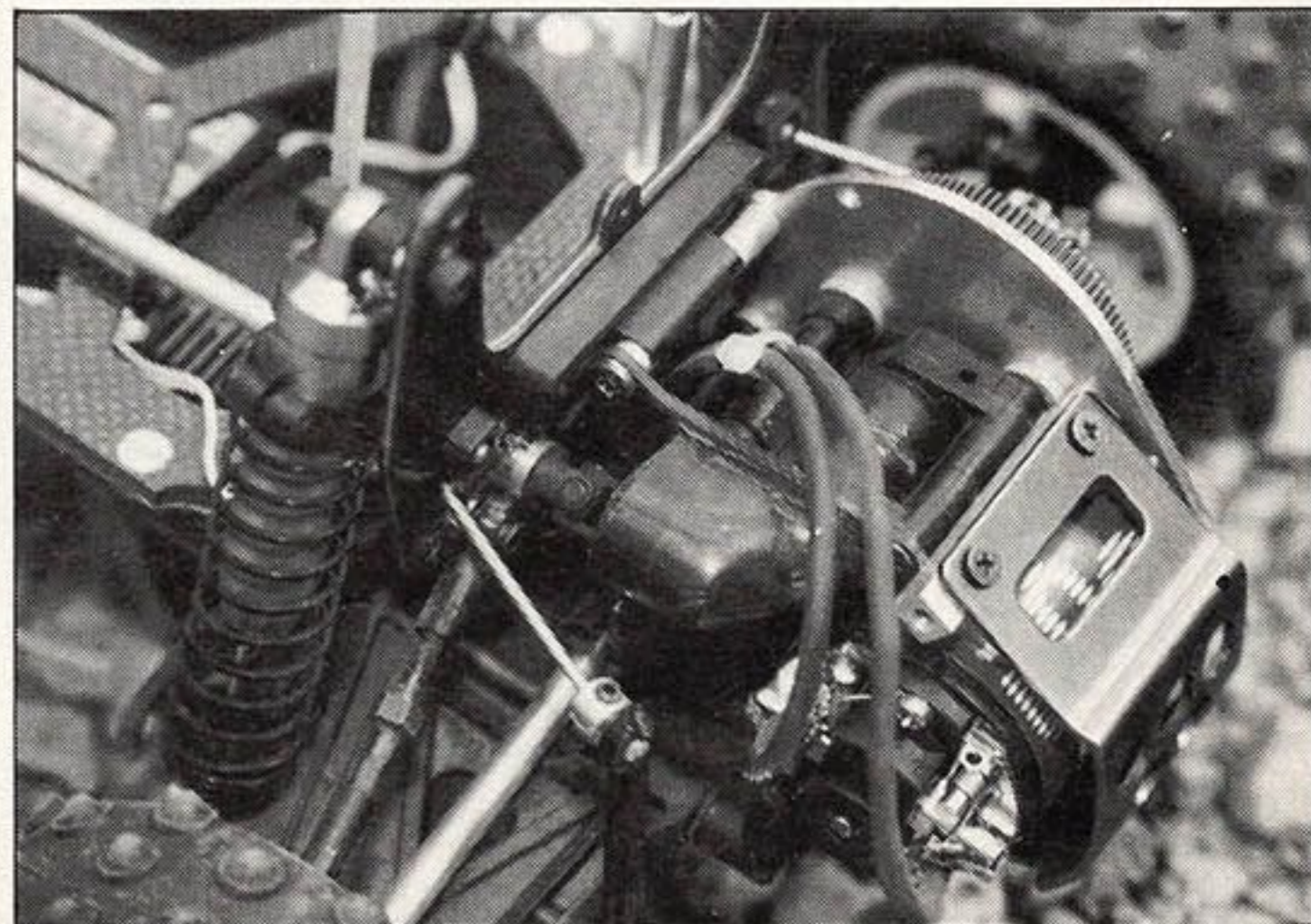

*Kyosho's secret weapon the new mid engined, belt driven Optima.*



*The event organisers.*

*Ernie Provetti and his charging technique.*



*The winning car complete with motor man.*



*Above, Jamie takes a drink, the other two go bathing.*

*Right, Ken McDowell the event sponsor and Parma boss.*

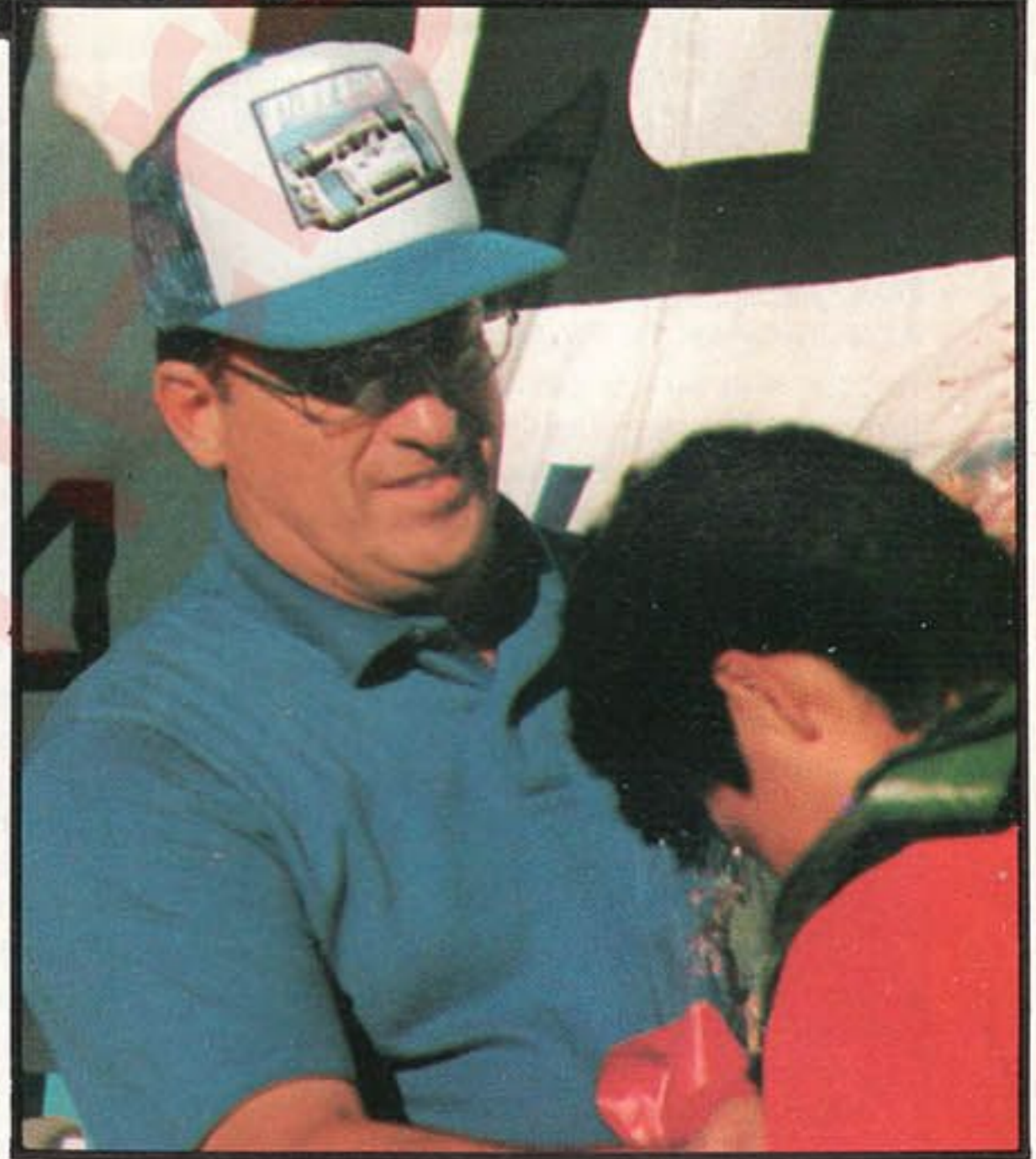

*Pole C.A.T.*

*The unnamed new Yokomo.*



*MIP's, 4WD RC-10 a super conversion from Eustace Moore.*

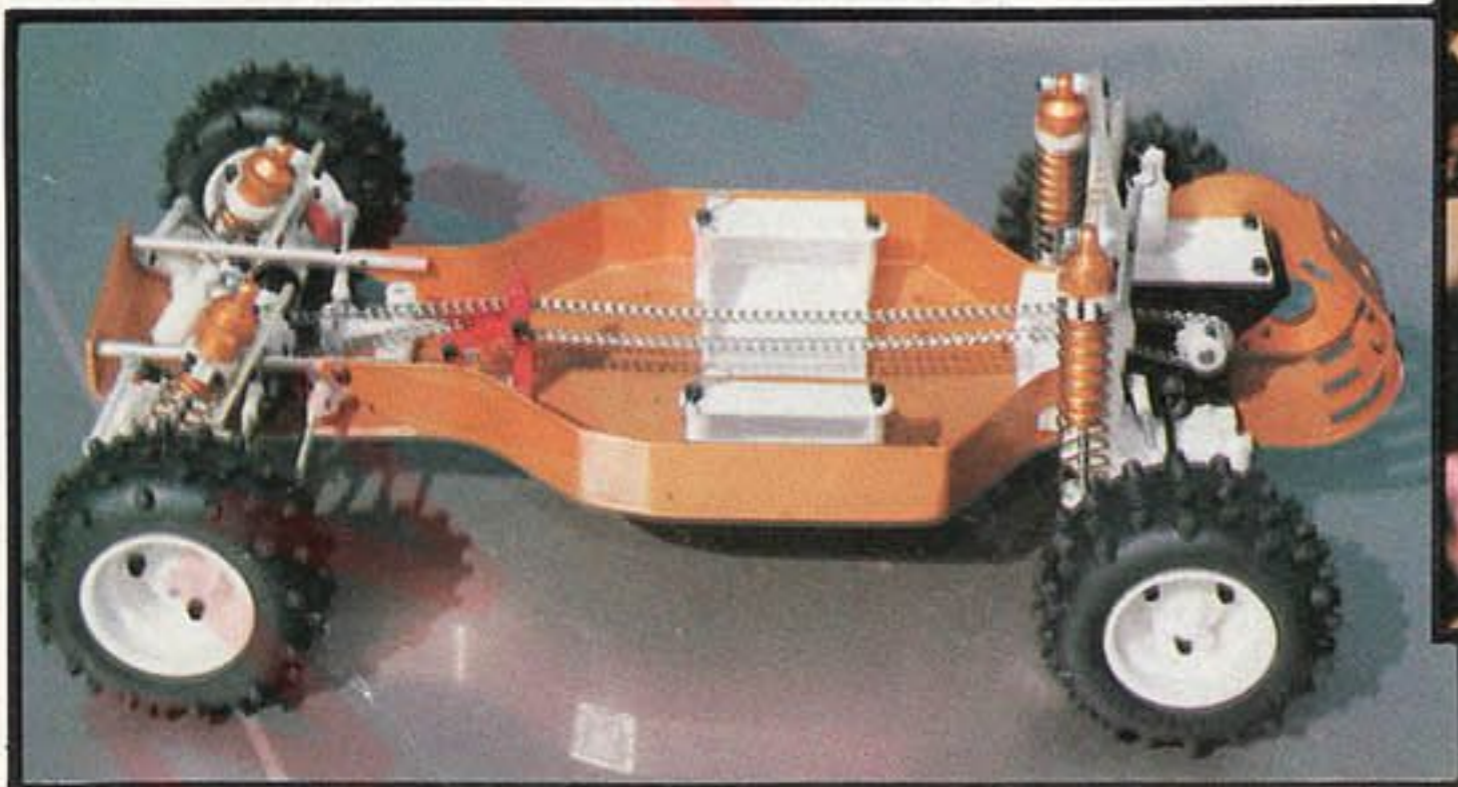

*Inside the pit tent everyone was busy, and so many languages all being spoken at once.*

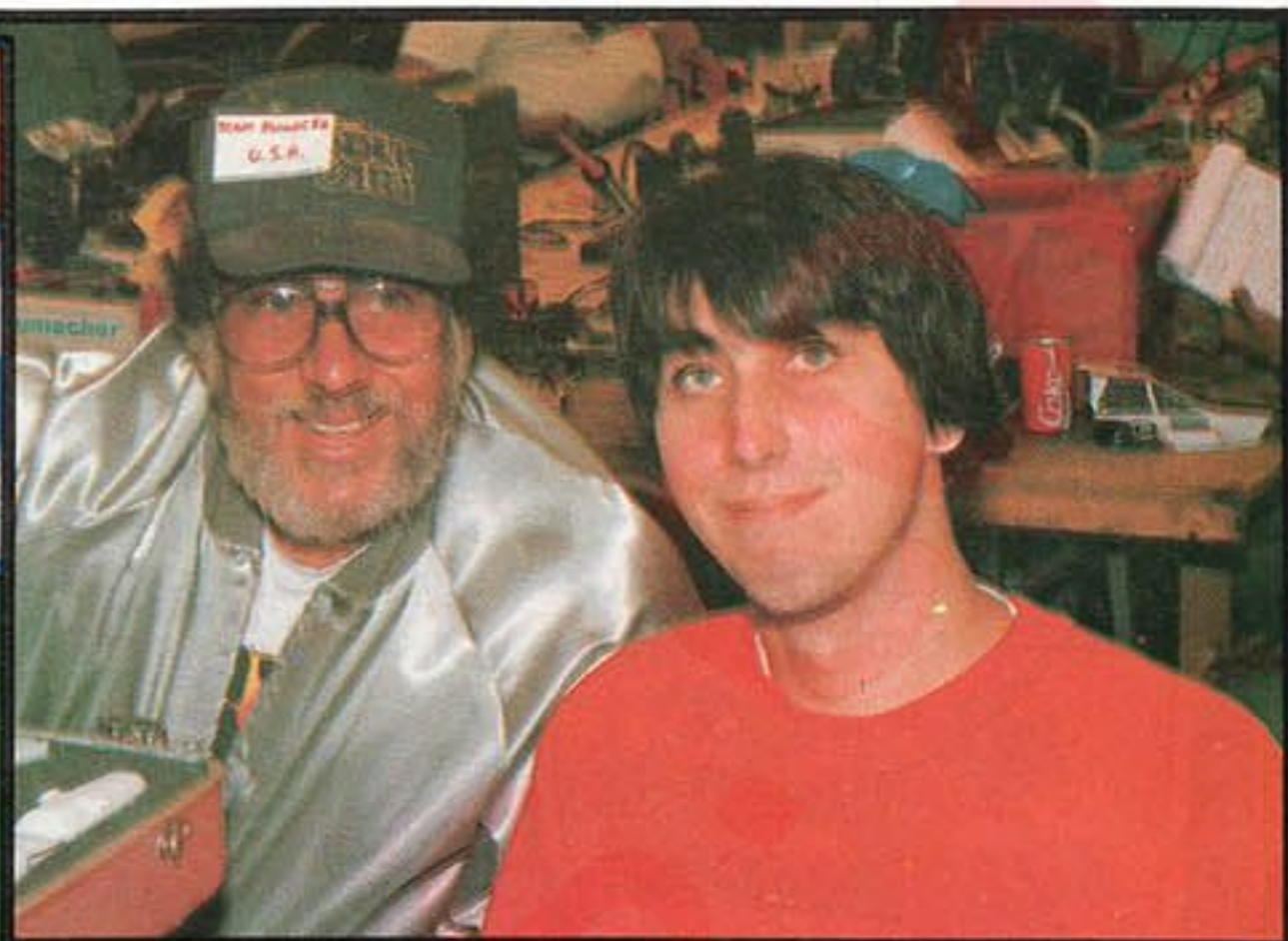
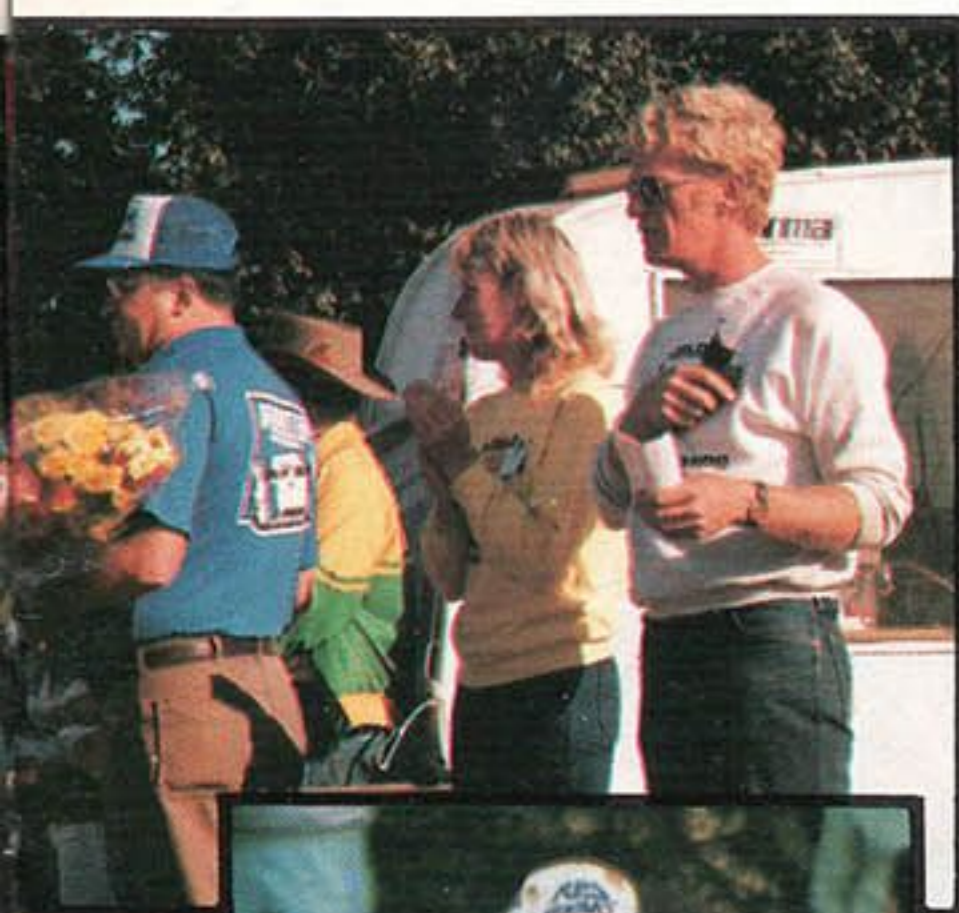

Pops and Jr. Losi, they fought hard and well with such new cars.

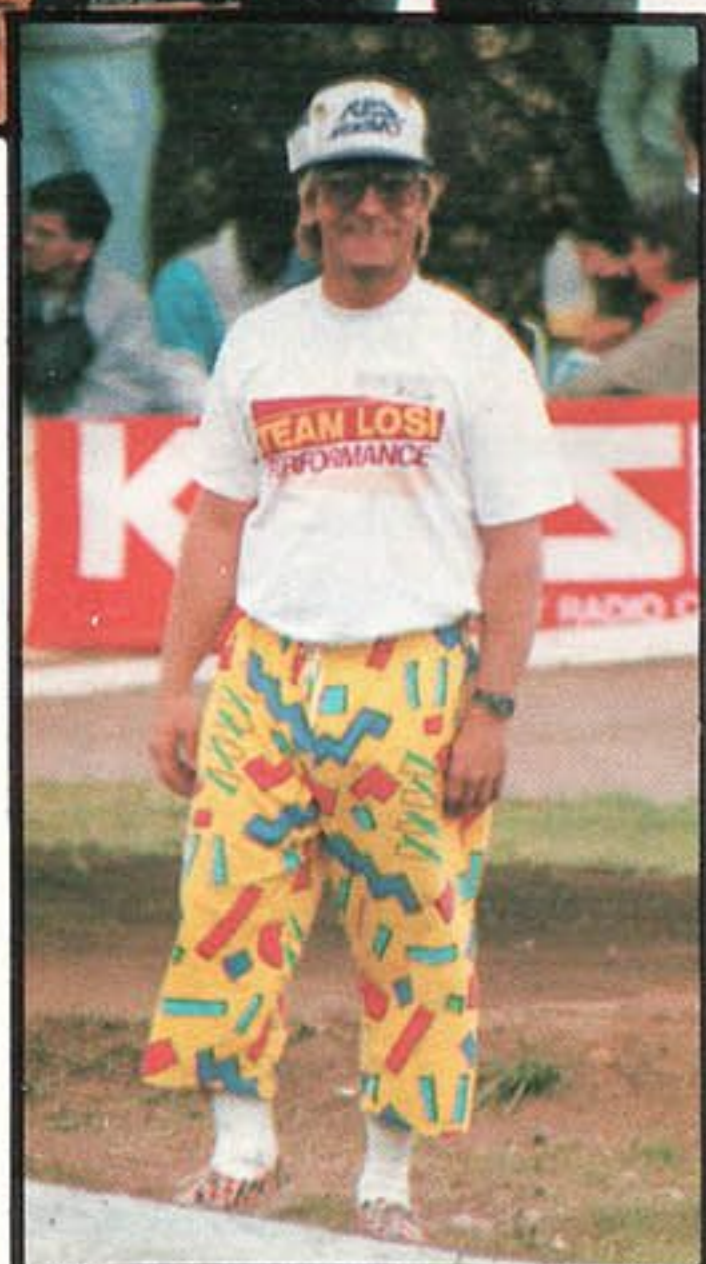

Dallas from Sweden proved to be "the man" as far as body art was concerned.

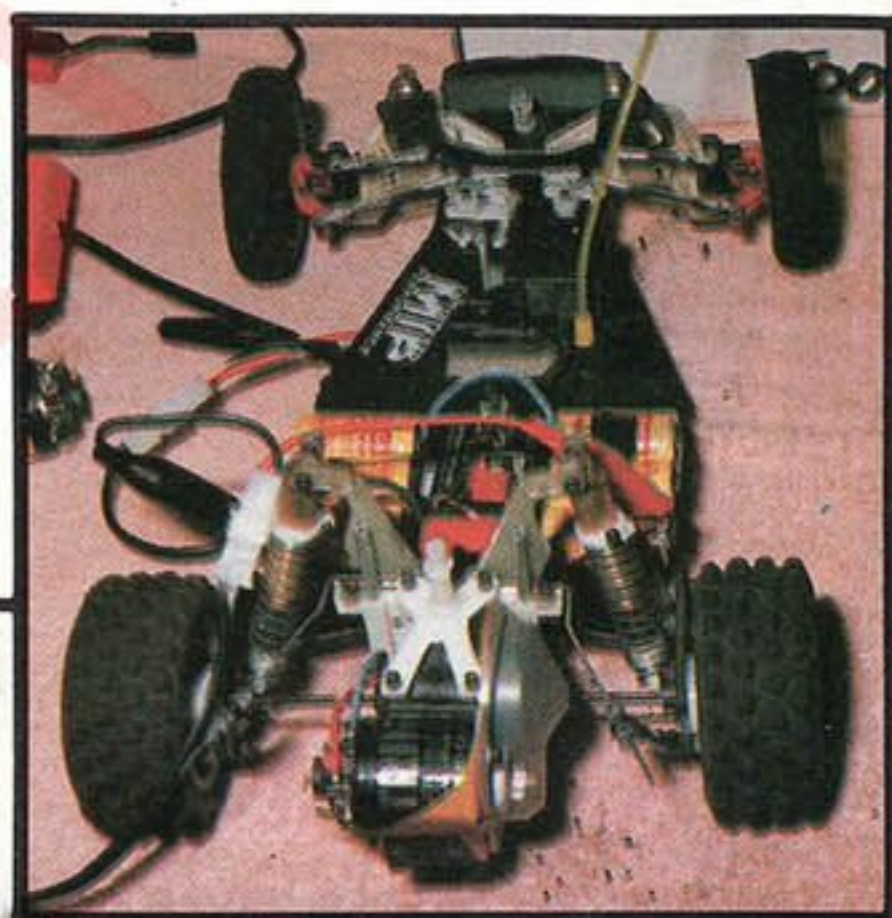

MIP 2WD Associated RC10

Ron Rossetti turned the volume up on these trousers.

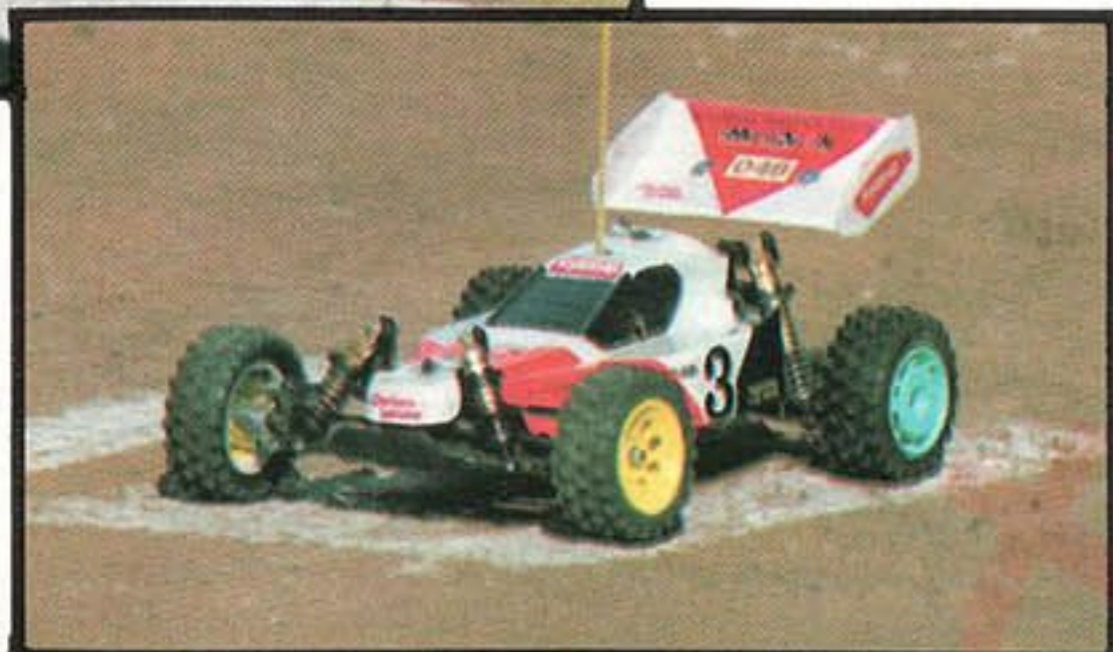
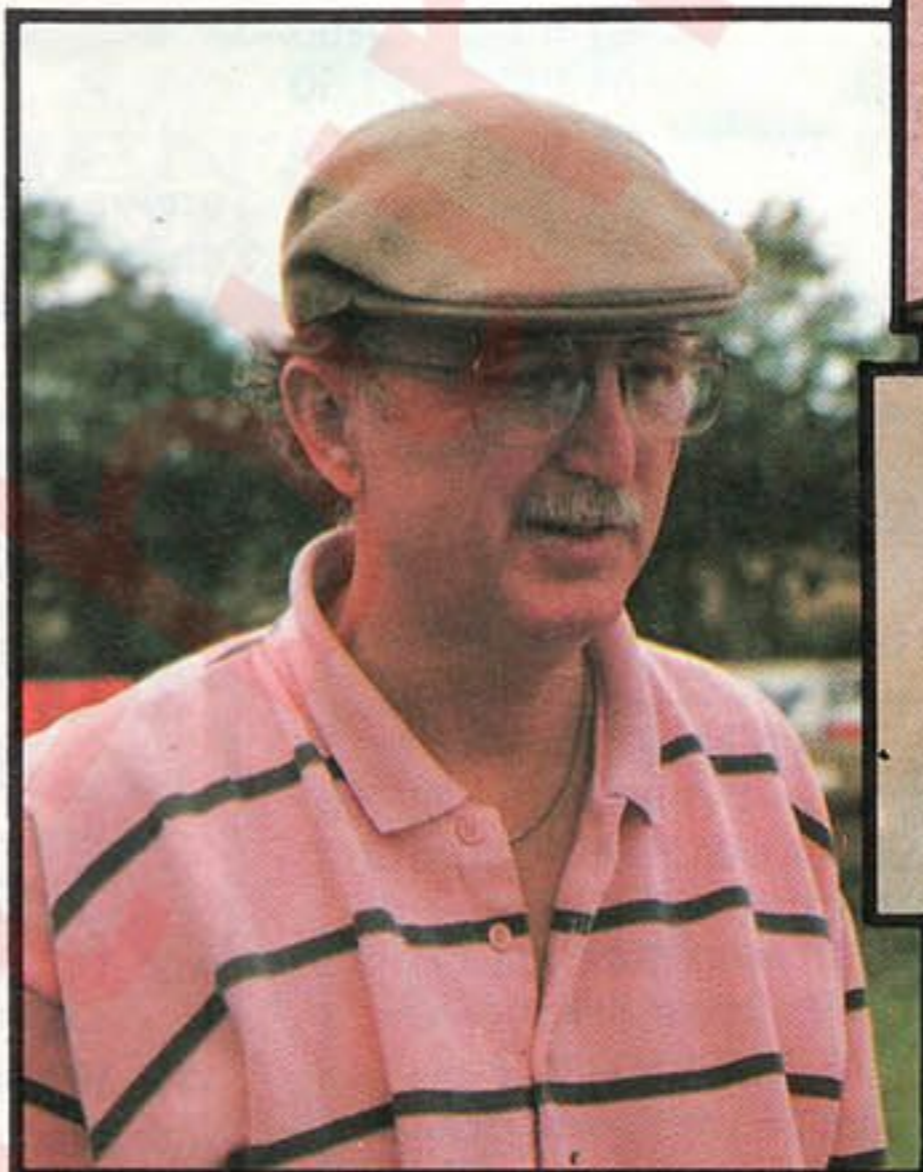

Optima on the line.



Left, the motor man himself Mike Reedy.

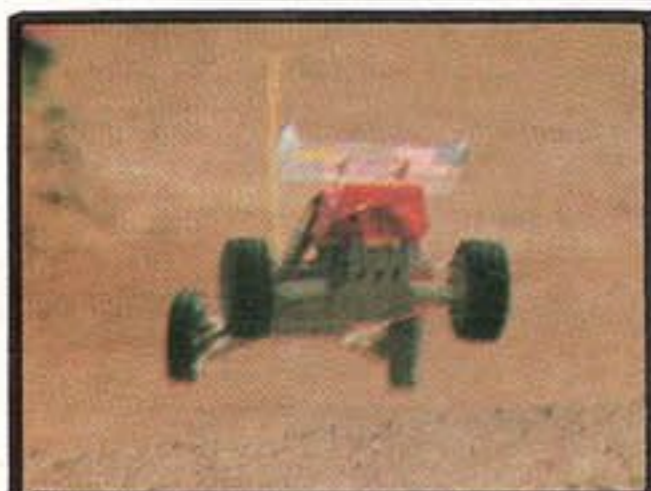

Left, Cecil Schumacher, a happy man.

The new T.A.G. Coyote.

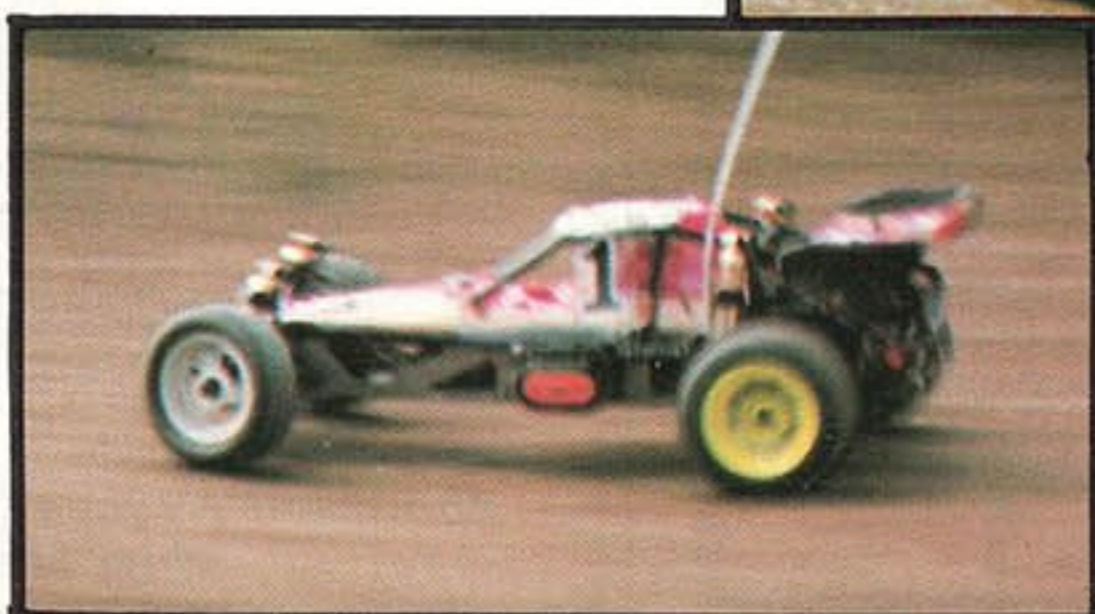
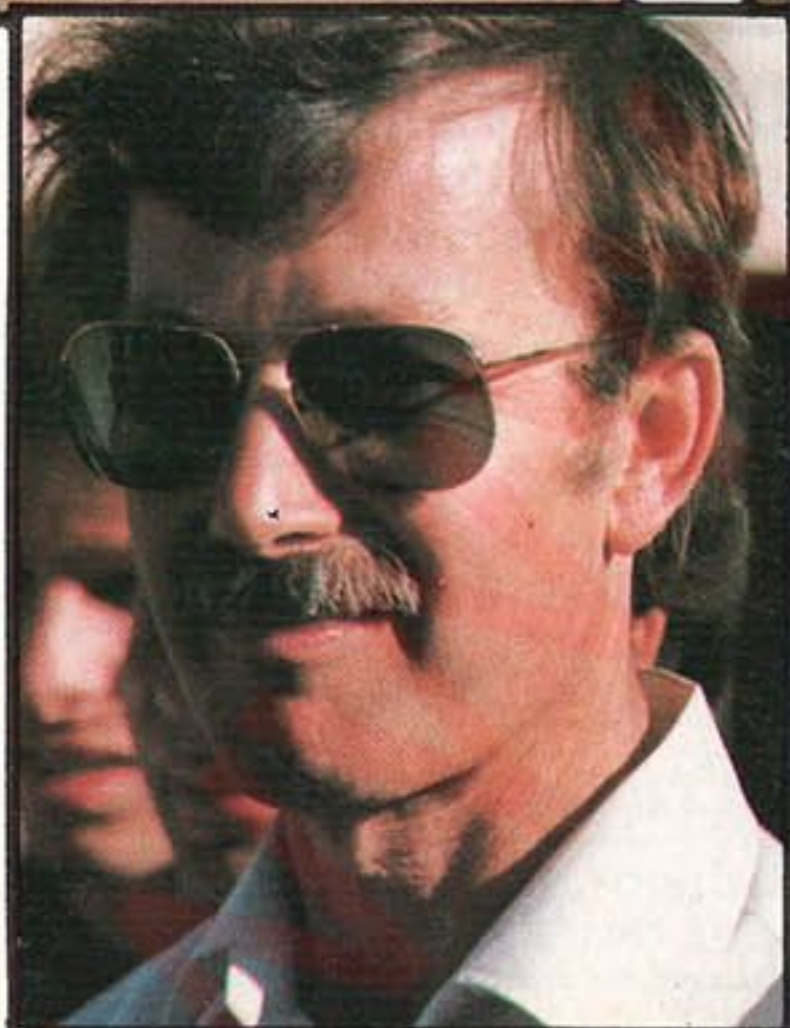

# MICHAELS MODELS

646 HIGH ROAD, NORTH FINCHLEY, LONDON N12 0NL. TEL: 01-445-6531

Mail Order a Pleasure

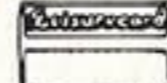
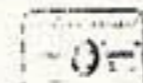

Postage Kits £2.50 Deals £3.25

Up to £500 Instant Credit Available to Shop Calling Customers Subject to Status (30.6% APR)

## MARUI NINJA



Kit £99.95 Deal £159.95

## MARUI GOLDEN EAGLE



Kit £47.50 Deal £119.95

## TAMIYA BIGWIG 7.2V 8.4V



Kit £149.95 Deal 7.2V 229.95 8.4V £237.95

## MARUI HUNTER



Kit £54.95 Deal £127.50

## TAMIYA BOOMERANG



Kit £92.50 Deal £159.95

## MARUI BIG BEAR DATSUN



Kit £54.95 Deal £127.50

	Kit	Deal		Kit	Deal
Tamiya Grasshopper .....	47.50	117.50			
Tamiya Falcon .....	64.95	137.50			
Tamiya Blackfoot .....	81.50	142.50			
Marui Samurai .....	84.95	149.95	Tamiya Monster Beetle .....	94.50	159.95
Tamiya Hornet .....	54.95	129.95	Tamiya Lunchbox .....		POA

## MD MOTILE MODEL DEVELOPMENT

2 LINKSIDE, NELSON, LANCS BB9 9LJ  
0282 691665

### ★ UK TYRE MANUFACTURERS ★

TYRES FOR FLIERS ★ TYRES FOR FLIERS ★ TYRES FOR FLIERS

#### 1/8 IC STOCKCAR

New Grey	Per pair
8001 .....	£4.50
8004 .....	£3.99
8005 .....	£3.99
Exec .....	£3.99
Soft .....	£3.99
MRC T9 Wets .....	£12.65

#### 1/10 OFF ROAD FOAM SLICKS

For Carpet & Tarmac  
Soft Med. Firm Rears  
£4.28 per pair

#### 1/12 MINI STOCK

Soft Med. Firm Rears £2.00  
Soft Med Firm Fronts £1.60  
per pair

MD TRACTION AT A FRACTION ★ MD TRACTION AT A FRACTION

#### KITS AND ENGINES

New Mardave Mini Stock .	£39.95	Mardave Stockmaster .....	£54.00
Mardave Meteor .....	£77.00	1/8th I.C. Stockcar Kit	
1/10th Off Road		Mardave Marauder .....	£49.50
Irvine 20 ABC Engine .	£45.50	1/8th I.C. Off Road	
Cipolla SE Buggy .....	£71.95	Associated 250 Clubman	
		Racer 1/8 I.C. Circuit .....	£69.50
		Associated RC300 Diff.	£50.00

#### I.C. STOCK TUNE UP AND SPARES

Bushed Radius Arms per pr .....	£3.00
Aluminium Drive Pulley	
40T, 36T, 32T .....	ea. £7.50
Crystal Extension .....	£3.45
PB Slide Carb for Irvine .....	£15.94
Sprung Chromed Car Stands .....	pr. £7.50
Drive Belts .....	£1.45
5 for .....	£6.00
Chromed Chassis .....	£21.70
Ball Joints, Pack 4 .....	£2.00
Bodies, various styles .....	£3.00
Air Filters from .....	£1.20
Blue Fuel Tube, 1/2 metre .....	£0.60

MANY MORE IN STOCK

STANDARD SPARES AVAILABLE FOR  
METEOR, STOCKMASTER  
MARAUDER, MINI & ASSOCIATER 250

0282 691665  
Orders over £10 post free in U.K.  
Orders under £10 50p p&p  
All kits, engines, chassis £1.50

Bodies £1.00  
MAIL ORDER

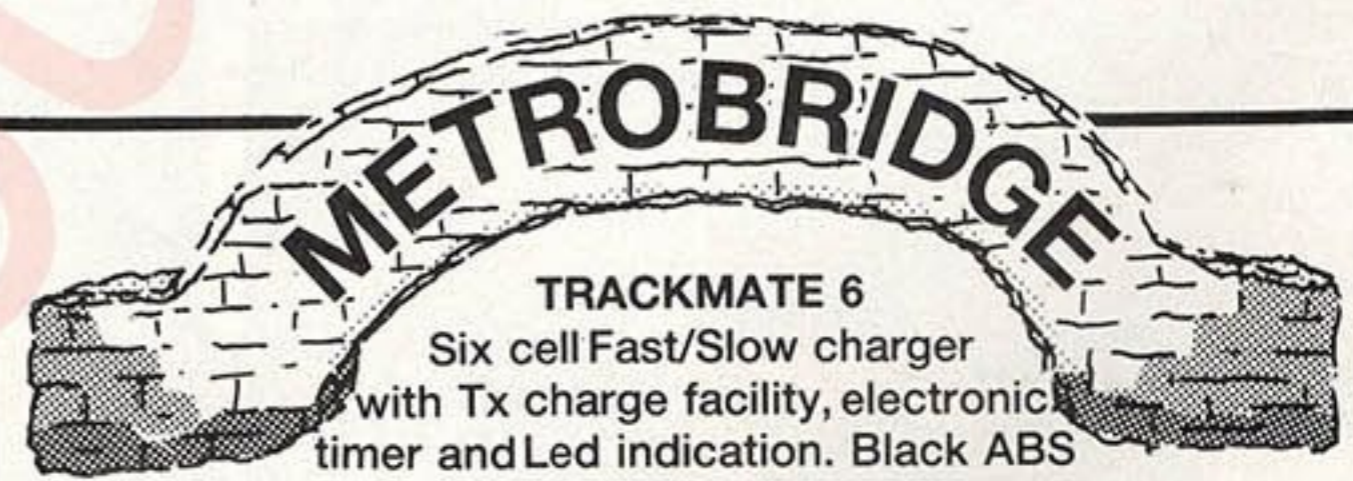

### TRACKMATE 6

Six cell Fast/Slow charger  
with Tx charge facility, electronic  
timer and Led indication. Black ABS  
casing £12.95 inc. VAT

TRACKMATE 6 PLUS, 4, 6 or 7 cell Fast/Slow charger  
with Tx charge facility, 0-6A ammeter for Fast rate indication and  
Led Slow indication. Black ABS casing £18.50 inc. VAT

TRACKMASTER PLUS, a full-feature Fast/Slow charger/discharger  
with electronic timer and current control. Die cast alloy casing  
£25.00 inc. VAT

Send SAE or phone for details:

Metrobridge Ltd., PO Box 687, Colchester CO3 5YR.  
Tel. (0206) 561714

## BRIMOD ENGINEERING DEVELOPMENTS

Universal Joint/Drive Shaft for the Mini Mustang and  
Boomerang etc. (no plastic, and a reconditioning service  
available).

10 x 14 / 10 x 20 / 10 x 30 Suspension Units  
Send for application sheet

If you didn't see us at the Modelex Show  
Get in touch with those below

PENN MODELS — WOLVERHAMPTON

GALAXY MODELS — NORWICH

PITSTOP MODELS — LONDON

WONDERLAND MODELS — EDINBURGH

ABBEY MODELS — NORTHERN IRELAND

45 Rooker Avenue, Parkfields, Wolverhampton,  
West Midlands, WV2 2DT



RADIO ACTIVE MODEL & LEISURE CENTRE WHERE THE CUSTOMER IS NO.1. RADIO ACTIVE MODEL & LEISURE CENTRE WHERE THE CUSTOMER IS NO.1. RADIO ACTIVE MODEL & LEISURE CENTRE WHERE THE CUSTOMER IS NO.1. RADIO ACTIVE MODEL & LEISURE CENTRE WHERE THE CUSTOMER IS NO.1.

# RADIOACTIVE

MODEL & LEISURE CENTRE

Specialists in Radio Controlled Models, Hobby and Leisure Activities

54 ST MARY'S LANE,  
UPMINSTER,  
ESSEX.  
RM14 2QT  
Tel: 04022 50272

## BUMPERS & STEEL PINIONS

### BUMPERS:

RA1 Boomerang-Bigwig	£3.95
RA2 Hornet — Grasshopper	£3.95
RA3 Bumper Blank	£3.95
RA4 Ninja	£3.95
RA5 C.A.T.	£2.50
RA6 Falcon	£4.95

Guaranteed virtually unbreakable through impact or we will supply replacement FREE. Order by part number to suit your car.  
Steel Motor Pinions — 9 sizes  
11t — 19t £1.90 each.  
Post free on all items  
Trade enquiries welcome

**NEW PINION CASE** Black plastic with clear lid. Holds 9 pinions (11–19t). Pinions fit snugly in base to enable you to use as gauge. Saves counting teeth **ONLY £2.95**

**SPECIAL OFFER! PINION CASE** complete with 9 pinions, (11–19t) plus socket wrench for **ONLY £16.95**

STOCKISTS of TAMIYA — KYOSHO — SCHUMACHER — YANKEE — MARDAVE — PB —

ALL KITS, SPARES & DEALS Plus accessories by PARMA — SRM — ASHBOURNE & many more too numerous to mention.

Phone for "DEAL" prices.

**FUTABA ATTACK COMBO £23.95**

**128 SERVO's only £13.95**

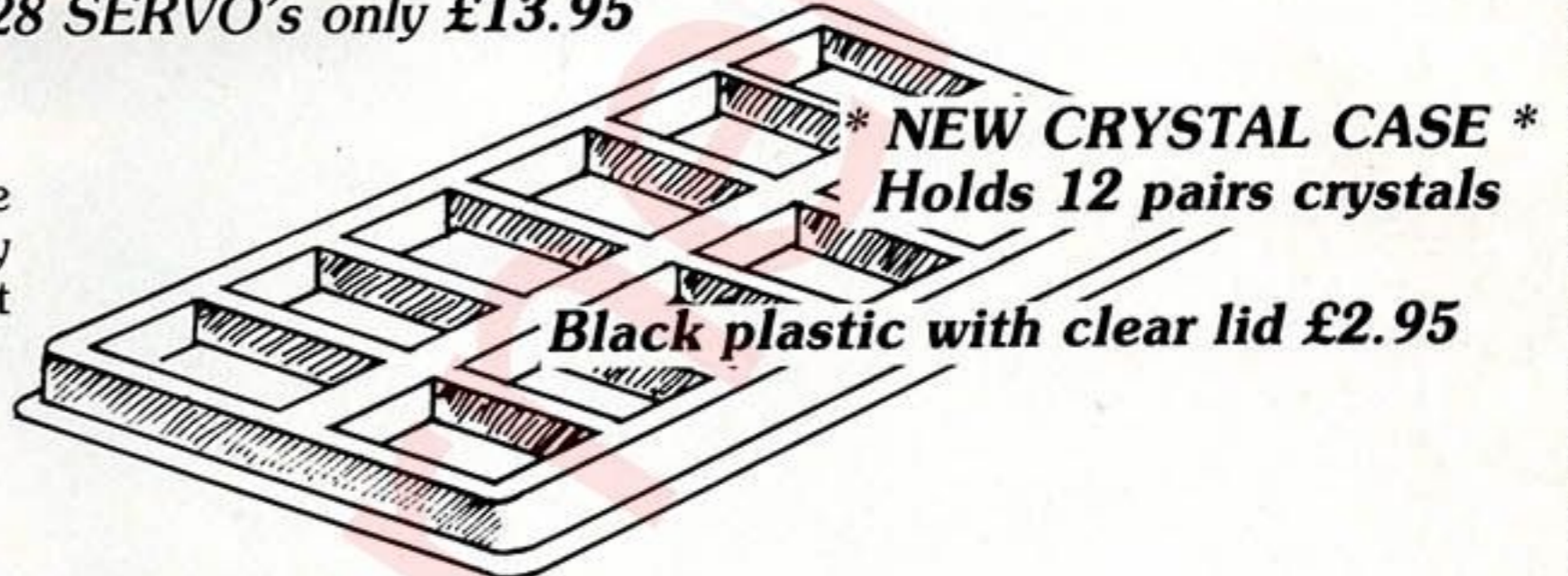

**\* NEW CRYSTAL CASE \***  
Holds 12 pairs crystals

Black plastic with clear lid **£2.95**

**FAST EFFICIENT "METERED" MAIL ORDER — WORLD WIDE**

## POWER TO THE MODELLERS WITH BATTERIES FROM

# JIM DAVIS

(PART OF THE HARRY BROOKS ORGANISATION)

## NICADS & SEALED LEAD-ACID ALL AT "THE BEST PRICES IN THE BUSINESS"

AA Nicads (HP7) 80p ea.

or 4 for £3

C size Nicads (U11) £1.89 ea.

D size Nicads (U2) £1.99 ea.

PP 3 size Nicads (9 volt)

£4.95 ea.

Special D size Nicads 4Ah

£3.95 ea

Special C size Nicads 2Ah

£2.95 ea.

Rx Packs (welded) 4.8v

£4.95 ea

Tx Packs (welded) 9.6v

£9.50 ea

### Sealed Lead-Acid

2v 8Ah £5.95 ea.

6v 8Ah £10.95 ea

6v 10Ah £12.95 ea

12v 6.5Ah £14.95 ea

12v 8Ah £19.95 ea

**FOR IMMEDIATE DELIVERY JUST "RING JIM" ALL CREDIT CARDS OK**

**TAMIYA STYLE PACKS** 7.2v Racing £14.95. 7.2v (Hump) £14.95. 6v £13.95. 8.4v £17.95

**JUST IN** Computer matched Sanyo SCR's with graph read-outs. Special intro-price £25 per set. Satisfaction guaranteed.

"Yes" we stock all makes of Nicads: Saft, Marathon, Sanyo etc.

WHEN JIM DAVIS & HARRY BROOKS "GET TOGETHER", IT'S GOT TO BE GOOD!

**JIM DAVIS SUPER MODELS, UNIT 4, THE PARKWAY, HENEAGE STREET, BIRMINGHAM B7 4LY.**

TEL: 021-359 0828



24 Hour Answering Service

01-868 7352

01-965 2122

31 BROADHURST GARDENS, EASTCOTE, RUISLIP, MIDDLESEX HA4 9JQ

### SERVICES:

COMMUTATOR — SKIM	£1.50
MODIFIED MOTOR — STRIP, CLEAN & SKIM	£4.00
STANDARD MOTOR — STRIP, CLEAN, SKIM & REASSEMBLE WITH SCREWS	£6.50

### TYRES:

GLUEING, TRUEING & SILICONING SERVICE ON YOUR OWN OR NEW HUBS & SLEEVES

INDOOR (FOR SILICONING) — ARMAFLEX, SUPER SOFT NEOPRENE, MEDIUM SOFT NEOPRENE

INDOOR (CARPET) — 03, 05, 06, 05/06, 07, 09

INDOOR (NON-TREATMENT) — 03, 05/06, 06, 09

OUTDOOR (ASPHALT) — 05, 07, 09

### SPARES:

KIMBOROUGH SERVO-SAVERS — DIFFERENTIAL GEARS

MCGREGOR RADIO EQUIPMENT

YOKOMO MOTORS & SPARES

SANYO BATTERIES

MR COOL MOTOR ADDITIVE — MOTOR OIL —

HEAT SHRINK — TRACK RODS — SERVO TAPE ETC.

### ACCESSORIES

TRAC TITE Tyre Conditioner 125ml	£2.95
TRU TYRES Motor Holder	45p
TRU TYRES Crystal Holder	95p
SARIK TOJ Bodies	Clear £5.60; Painted £8.60

### CARS:

Tru-Tyres 'Tornado' 1/12th Scale Car (Beam)	£71.85
Tru-Tyres 'Typhoon' 1/12th Scale Car (Beam)	£100.97
(with wishbones)	£107.07
Typhoon Conversion Kit (Beam)	£60.90
Typhoon Conversion Kit (with wishbones)	£67.00
Flat-beam Conversion kit for Demon car	£16.88
Tru-Tyres Differential	£13.50
Beam to Wishbone Conversion	£10.00

TRADE ENQUIRIES WELCOME

Prices not quoted available on request

**"A PRETTY, PUNY,  
WIMPY MOTOR DID  
JOEL JOHNSON THE**



**BUT A  
BETTER**

**TWO STRAIGHT 1/10th**

**JOEL JOHNSON,  
1987 2WD WORLD CHAMPION  
AND 12 TIME NATIONAL  
U.S. CHAMPION**

"For more consistent wins  
than any other motor I use  
Trinity Monster Horsepower."

**SISSY, LITTLE  
DON'T WIN  
THE WORLD CHAMPS ...**



**TRINITY DID!"**

**I.F.M.A.R. WORLD TITLES**

**Look for Trinty's perfect  
matched batteries and  
other exciting products.**

**AVAILABLE MOTORS**

- RC# 2000 — "Trinty Stock Motor"
- RC# 2002 — "Custom Sprint Motor"
- RC# 2003 — "Enduro Motor"
- RC# 2004 — "Pure Gold"
- RC# 2005 — "Oval Motor"
- RC# 2007 — "Drag Motor"

**Look for Trinty's new RC#2009 Ultima-TE  
"Silver Dot" World Championship winning  
motor and the following new Ultima parts**  
RC#8028 Graphite Plate w/kick up front end  
RC#8025 Graphite Front Shock Towers  
RC#8026 Graphite Rear Shock Towers

**TRINITY**

**1901 E. Linden Avenue #8, Linden,  
New Jersey 07036 Phone: 201 862 1705  
Telex: 4971468 TRINCORP  
Fax: 201 862 6875**

# WONDERLAND MODELS

97 LOTHIAN ROAD, EDINBURGH. Tel:031-229-6428  
Hours: 9.30 - 6 Mon-Fri 9-5.30 Sat.

<b>PB MINI-MUSTANG</b>	
2WD Single Speed	£139.99
4WD Single Speed	£159.50
4WD Twin Speed	£179.99
SRM One Way Drive Shafts	£21.95
SRM Ballraced Belt Tensioner	£5.99
Brimod Universal Joint D/Shafts	£30.00
Brimod Shocks	pr. £22.50
Brimod Shock Mounts	ea. £3.30
All PB Spares in Stock	

Associated R.C.10 Kit £100.00  
Body £9.99 Motor £12.00 Bumper £3.99  
Bearing Set £40.00 Tyres from £2.99  
All associated spares in stock

<b>BATTERIES</b>	
NEW MIH Pushed Yellow Cells	£29.99
NEW SCR Pushed Cells	£35.00
Tamiya 6v	£18.99
Sanyo Yellow Cells	£17.99
or 3 for	£40.00
Sanyo Yellow Cells 1.3AH	£18.99
Sanyo Red Cells	£19.99
Sanyo Spec. Select Red Cells	£24.99
or 3 for	60.00

Ultima	£95.00
Striker	£59.99
Monster Beetle	£99.99
Blackfoot	£89.99
Falcon	£69.99
Grasshopper	£49.99
Hornet	£59.99
Bigwig	£155.00
The New Hot Shot II	£114.99
The New Lunch Box	£69.99

Phone for our best Deal Price. We will match advertised prices

Boomerang Strengthened D/Shafts	pr £4.99
One Way Drive Shafts Front	£21.95
Front Suspension Brace	£1.95
Widen Track for Fox Wheels, set 4	£5.99
Hot Shot Wheel Mounts, for 4	£8.50
Universal Parma Body Mount set	£4.99
All Parma Bodies stocked from	£9.99
Parma Battery Plugs	pr £1.75

Long Wheelbase Kit	£25.00
Schumacher Cat	£175.00
Peak Charger PCI	£33.00
Spiked Tyres Soft	pr £6.00
Spiked Tyres Hard	pr £6.00
Also fits Tamiya Hotshot Wheels	

Salute	£179.99
Kyosho Optima	£119.99
Turbo Optima	£189.99
Option House Motor Guard	£5.95
Brimod Shocks Fr. & Rear	pr. £22.50
Brimod Shock Mount Kit	£2.99
Option House Shocks	pr. £22.95
Option House Drive Shafts	pr. £19.95
Celebration Chassis	£25.95

<b>MOTORS</b>	
SRM Scorchor	£12.00
Demon 27T	£12.00
Demon 19T	£12.00
Demon 22T Double	£12.00
Kyosho Spirit 600	£12.00
Parma Yokomo	£12.00
Parma Sprint Mod	£40.00
Parma S/Sprint Mod	£40.00
Parma Oval Rac. Mod	£40.00
Kyosho Le Mans 480T	£25.00
Associated Motor Brushes	£1.99
Twister Mod. 19 x 2 & 17 x 3	£40.00

Demon 20T Double Mod	£23.00
Demon 22T Double Mod	£23.00
Demon 16T Triple Mod	£25.00
Demon 19T Quad Mod	£25.00
Demon Power King	£40.00
Technipower	£34.99
Technitone	£34.99
Technigold	£39.99
Motor Springs	£1.25
Capacitors	£0.25
Brushes Hard + Standard	£1.99
Cut Down reedys	£3.25
Pinions 8T to 19T	ea. £1.95

Hot Shot	Boomerang	Fox	Hornet	Bigwig
1/32 Motorised Car Kits				
Only £4.99 each				

<b>RADIOS</b>	
Acoms Technidrive	£49.99
Acoms Techniplus BEC	£55.00
Futaba Attack & BEC	£55.00
Crystals	pr £4.25
All Split Crystals in Stock £4.50	

<b>TYRES</b>	
Mardave Blocks, 5 x 4, 3 x 2	pr. £3.60
Cat Front & Rear Spikes	pr £6.00
Tamiya Pin Spiked	pr £4.50
Tamiya Oval Blocks	pr £4.50
Tamiya Colour Tyres Red, Yellow, & White	
Pin spiked & Oval Block	
Fronts	£4.99
Rears	£6.99
Hornet Rears Spiked	pr £6.50
RC10 Rears Spiked	pr £6.50
Hot Shot Dynamite Front	pr £6.50
Hot Shot Dynamite Rear	pr £6.50

Liquid Thread Lock	tube £1.50
Molybdenum Grease	tube £2.70
Switch Lubricant	tube £2.50
Nicad Heatshrink	£1.25
Wires Heatshrink	£1.00
Velcro	£1.75

<b>BODY SETS</b>	
Blackfoot	£25.99
M/Beetle	£25.99
Hornet	£14.99
Grasshopper	£12.99
Porsche 959	£24.99
Boomerang	£13.50
Falcon	£14.99
Fox	£15.50
Brat	£17.99

<b>ELECTRONIC SPEED CONTROLLERS</b>	
Laser Comfet fwd & rvse	£65.00
Laser Bug fwd & rvse	£49.99
Lectricar 5 Fet Forward & Reverse	£60.00

MAIL ORDER £2 ON RADIOS AND KITS, £3.50 on DEALS, £1 MIN. ON SPARES  
**SAME DAY DESPATCH**

PRICES CORRECT AT TIME OF GOING TO PRESS, BUT PRICES MAY CHANGE WITHOUT NOTICE.

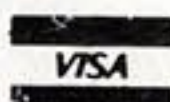

SPECIALIST MAIL ORDER  
SUPPLIERS OF CAR KITS  
SPARES & ACCESSORIES

21, Whitburn Street, Bridgnorth,  
Shropshire WV16 4QN, England.  
Tel: (07462) 2291. Telex: 336596 BCL UK G

RADIO CONTROL PRODUCTS

## RCP THE CAT SPECIALISTS

We stock a comprehensive range of spares for the CAT. Hundreds of items in stock including all the latest modification and tune up parts.

## RCP for MOTORS

We have over 200 motors in stock - both standard and modified - all the big names:-

DEMON	—	TRINITY
M.G.	—	MIKE REEDY
SCHUMACHER	—	SRM TWISTER
KYOSHO	—	PARMA.

Plus full range motor accessories, including steel pinions, springs, ballraces, cleaners, brushes (hard, soft, contoured, cut), etc.

## RCP for TUNE UP PARTS

Wide Selection of parts from all the big names:-

SRM	—	PARMA
TMS	—	BRIMOD
NODIS	—	KYOSHO

## RCP for ACCESSORIES & SPARES

You name it - we've got it. "The pick of the best".

For further details, send for your FREE RCP Catalogue and Price List Now.

We are specialists in the supply of 1/10th Buggy cars, spares and accessories for the experienced enthusiast or novice. Write or phone for our free comprehensive catalogue and price list.  
MAIL ORDER HOTLINE - TEL: BRIDGNORTH (07462) 2291 (24 hours).  
RCP offers a fast and efficient fully insured mail order service. Credit card orders same day despatch (subject to availability). Please allow 7 days for clearance of cheques.  
Expert enquires welcome. (VAT free).  
Opening Hours: Monday - Saturday 9am - 6pm

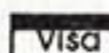
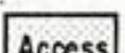
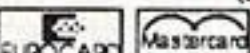

Postage/Packing/Insurance: £2.50 for kits/package deals  
-spares and accessories 75p per order (UK only). Export at cost.

Building & Repair Service Available.



Electra Kit £166.00  
Fully Ballraced  
£186.00



★★★★ NEW PARTS ★★★★★

Metal Drive Shaft Assemblies with U/J's fitted . £22.00 pair  
Motor Pinions 11T/12T

£3.20 each

Anti Roll Bar Kits ..... Front £5.75 Rear £6.30

Increase performance and running time by fitting belt driven centre differential  
price to be announced



Car Kits ... Boat Kits ...  
Chargers ... Lexan Bodies  
Decal Sheets ... Shock Absorbers

Now available direct from:

J & P Turner, Orchard Corner, St Pauls Cray,  
Orpington, Kent. Tel: 0689 32082 0634 67598

Dealer Enquiries Welcome

# Ralls Racing Models

Suppliers of competitive quality kits and accessories  
24 Military Road, Ramsgate, Kent. CT11 9LG.

NO SHOP AT THIS ADDRESS

Mail order. Most Credit cards.  
Tel: 0843 591036 daytime,  
0843 580832 evenings

- PB Mini Mustang Spares and accessories
- PB Mini Mustang 4WD. Single ..... £159.50
- 4WD. 2 speed ..... £179.97
- 03/12 2 speed box ..... £29.52
- 07/10 1 way drive shafts 2 ..... £17.50
- RRM pack, M2 x 12 posi pan hd. screws and nuts, needed to replace self tappers in PB centre spline, 5 each ..... £0.45
- RRM our own strong ally uprights, direct replacement for PB type F/R pr. .... £8.50
- New belt system and UJs when available
- Most screw packs, allen keys etc. stocked

**WE STOCK ALL 1/10 PB 4WD SPARES**

- Popular PB Spares
- 01/11 Chassis mldgs LH & RH ..... 7.49
- 02/10 Suspension mldgs ..... £1.44
- 02/13 or 14 Shocker packs each ..... £6.19
- 02/15 Shocker first aid packs ..... £2.07
- 03/11 Diff mldgs ..... £2.25
- 03/15 Bat.clmp.axle blk.s wh.dr.s ..... £1.95
- 03/30 Belt drive 4WD ..... £2.78
- 03/36 Motor plate lexan cover ..... £0.48
- 03/42,3,4, 56, 58, 60t counter gear ..... £1.01
- 03/74 Silc tube thrust pad ..... £0.25
- 04/10 Bumper & B/crank mldgs ..... £2.89
- 06/11 4WD. ballrace pack 14 Brg. .... £24.28

- Lexan undertray fits PB ..... £5.75
- SRM B/race belt tensioner ..... £5.95
- SRM G/steel S/S posts ..... £5.45
- SRM Polybone drive shafts ..... £3.95
- SRM PB to Cat C/gear adaptor ..... £3.95
- SRM PB to W/one wheel adaptor 4= ..... £5.95

- Yankee Electra fully B/raced ..... £186.00
- Steel drive shafts with UJs or, ..... £22.00
- Special pinions 11T & 12T ..... ea £3.20
- Schumacher
- 1/10 CAT kit ..... £175.00
- T146 XL chassis plate lower ..... £5.80
- T147 XL chassis plate upper ..... £3.99
- T152 XL belt ..... £3.35
- T526 Front diff ..... £16.95
- T529 lwb body ..... £7.97
- T530 lwb under tray ..... £7.62
- T642 XL conversion kit ..... 25.00
- Allow £1.00 p&p on XL kit, body or tray

**WHEELS & TYRES**

- PB F/R hub, also fits Hotshot pr. .... £1.49
- PB very soft pindot tyre F ..... £4.20
- PB very soft pindot tyre R ..... £4.70
- Dynamite TS-2211 Fr. PB H/shot ..... £6.50
- Dynamite TS-2212 Rr. PB H/shot ..... £6.50
- New Dynamite TC-1121 Fr. PB H/shot ..... £4.20
- New Dynamite TC-1122 Rr. PB H/shot ..... £4.70
- Tamiya Hotshot spike Fr. pr. .... £4.20
- Tamiya Hotshot spike Rr. pr. .... £4.70
- Cat. Orig. spike hard or soft Fr. pr. .... £5.80
- Cat. Orig. spike hard or soft Rr. pr. .... £6.30
- Dynamite TS-2213 Rr. Hornet ..... £6.50
- Optima to PB wheel adaptors ..... 2 = £4.25
- Optima to W-one wheel adaptors 4 = £5.95

**CAR BODIES**

- PB Scalpel ..... £7.94
- PB Stiletto ..... £7.94
- Demon Dart Optima, RC10 ..... £7.50
- Raceco 1/10 Optima PB ..... £8.60
- Lexan wing 1/10 ..... £2.50
- Associated wing and wire kit ..... £2.80
- 1/10 Body clips ..... 4 = £0.79
- 1/8 Body clips ..... 5 d £1.30
- 1/12 Body Associated TOJ ..... £7.50

Orders telephoned by 3pm and payment by Access & Visa despatched same day.  
Postal orders same day.  
Cheques please allow 7 days for clearance.  
Orders £10 and below allow 50p P & P, over £10 free.  
Nicads &/or bodies £1.00 P & P

- NICADS (28.7.87)A
- Sanyo Technicad SCR. Std. .... £19.95
- Technicad SCR.S/S ..... £24.95
- CS Computer matched SC ..... £24.95

**MOTORS**

- MG. BrownDot Std 27x1 ..... £12.00
- And after purchase, Zapp & brushes ..... £3.50
- SRM Scorchler Std 27 x 1 ..... £11.95
- Demon Std 27 x 1 ..... £12.00
- Demon Mod 21 x 2 ..... £25.00
- Demon Mod 20 x 2 ..... £23.00
- Parma Sprint 19 x 2 ..... £39.95
- MG Red dot plus 19 x 2 ..... £25.95
- Demon 18 x 4 ..... £25.00
- Intronics 17 x 2 ..... £40.00
- MG Red dot plus 17 x 2 ..... £25.95
- Demon Power King 17 x 3 ..... £40.00
- Demon 16 x 3 ..... £25.00
- SRM Stunner 1/12 35T ..... £13.50
- Intronics 1/12 35T ..... £13.50
- Demon 1/12 35T ..... £12.00
- Brushes std or hard ..... pr. £1.95
- Motor capacitors, each ..... £0.15
- Mr Cool comm drops ..... £2.10
- Revtech BCD comm drops ..... £2.95
- Reedy power spray ..... £2.95
- RS. Motor cleaner large can ..... £2.95
- Reedy motor cleaner v/large can ..... £4.25
- Foam motor boot (yellow) ..... £1.25
- Gauze M/boot. imperv. to sprays ..... £1.95
- Rubber Motor boot ..... £1.50
- Pinions steel 9T-20T ..... £1.85

**SPEED CONTROLLERS**

- (When available)
- Demon King 6 fets ..... £45.00
- Demon Pro King 8 fets ..... £60.00
- Demon 1/12 Big Devil ..... £50.00
- Laser comfet bug ..... £69.95
- PB speed controller

**CHARGERS**

- Laser Temp sensing pulse charger ..... £36.95
- Intronics thermal charger with digital thermometer ..... £44.95
- Schumacher new spec PC1 peak ch. .... £33.00
- MRP 112 12vx5-7 cell plus discharge analog. Trickle, timer, fused ..... £24.00
- MRP 105 12vx5-7 cells + trickle ..... £16.95
- MRP cord charger 6 or 7 cells ..... £5.00

**MISCELLANEOUS**

- Cyno glue in single drop dispenser for added safety. 2g bot. .... £2.25
- Loctite Lock'n'Seal, threadlock ..... £1.70
- Fibreglass comm cleaning pen ..... £3.40
- Fibreglass refills for above ..... £0.45
- Servo tape. 4 pieces 6" x 1" ..... £0.50
- 15A H/D single pin connectors inc. heatshrink 2 prs. .... £1.25
- H/current silc. wire. Red & Bl. 3ft ..... £1.50
- Parma 12v soldering iron ..... £10.45
- Parma nicad cooling fan ..... £7.85
- Super H/D T/rod ball joints, 4 ..... £5.00
- Kimbrough/Fut.Spl.servo saver ..... £2.40
- Shock oil with anti leak agent 10, 15, 20, 30w grade 2 oz bot. .... ea. £1.50
- M3 grub screws for pinions ..... 6 = £0.50
- Allen key for M3 grub screws ..... ea. £0.25
- 5" Cirscip pliers used on PB ..... £7.45
- Silicon based bearing oil ..... £2.95
- Motor oiler 1/2oz bot. oil & needle ..... £1.20
- Silicon grease tube ..... £1.30
- Ball type allen key with handle to fit motor fixing M3 cap screw, used on PB & Cat. allows 15 degrees of misalignment to get round shockers ..... £3.95
- Heat shrink 65mm for nicads 1/2mt. .... £0.70
- Heat shrink 80mm for S/controller ..... £0.90
- H/D steering rod end kit ..... £6.45
- Crystals, only solid colours ..... pr. £4.00
- Aerial tube ..... £0.50
- Chassis mtg. for aerial tube ..... £0.50
- Shock clamps. Fit Associated and Option House type shockers ..... £1.50
- M4 Nyloc nuts (wheel nuts) ..... 5 = £0.27
- RC10 Super H/D upper link ends and tie rod ends kit ..... £17.75

This list is growing daily, so give us a ring, we might now be stocking the items you require.

AND LOTS LOTS MORE

# nodis racing developments



28, Brunswins Close, Wickford, Essex. Tel: 0268 732581  
WORKS: 1-8 Yorse Yard, Essex Road, London N1 Tel: 01 226 2511

**NODIS TUNE UP PARTS**

**OPTIMA**

- Belt Driver Conversion Kits
- Slipper Clutches
- Fine Pitch Gears
- Compound Gears Various Ratios
- Layshaft Gears
- Final Drive Gears
- Fine Pitch Motor Pinions

**ASSOCIATED RC10**

- Four Wheel Drive Conversion Kits
- Fine Pitch Spur Gears
- Custom Built Gearboxes

**SCHUMACHER CAT**

- Precision made Differentials
- Precision made Integrator Units
- Machine Cut Differential Pulleys
- Fine Pitch Spur Gears
- Fine Pitch Motor Pinions

**MINI MUSTANG**

- Fine Pitch Spur Gears
- Fine Pitch Motor Pinions

**CORALLY**

- Fine Pitch Differential Gears
- Fine Pitch Long Boss Motor Pinions

All Gears are machine cut and made from Tufnol and Steel  
Gearbox design and development  
Differential design and manufacturing service available

TRADE SUPPLIED



**STRIKER  
FALCON  
PORSCHE  
MONSTER BEETLE  
LUNCHBOX**

**HORNET  
BLACKFOOT  
BOOMERANG  
BIGWIG  
HOTSHOT II**

PRICES ON APPLICATION

	Kit	Deal
MARUI NINJA	£88.95	£149.95
MARUI BIG BEAR	£49.95	£109.95
MARUI HUNTER	£49.95	£109.95

**MARDAVE METEOR DEAL WITH SANWA 2CH £122.95**

**CHALLENGER KANGAROO £99.95 inc. RADIO**

**61 SPON END, COVENTRY. Tel 0203 76409**

ORDERS BY TELEPHONE SAME DAY DESPATCH.  
PLEASE ADD POSTAGE £2.75 KIT, £3.75 DEALS  
BARCLAYCARD/ACCESS

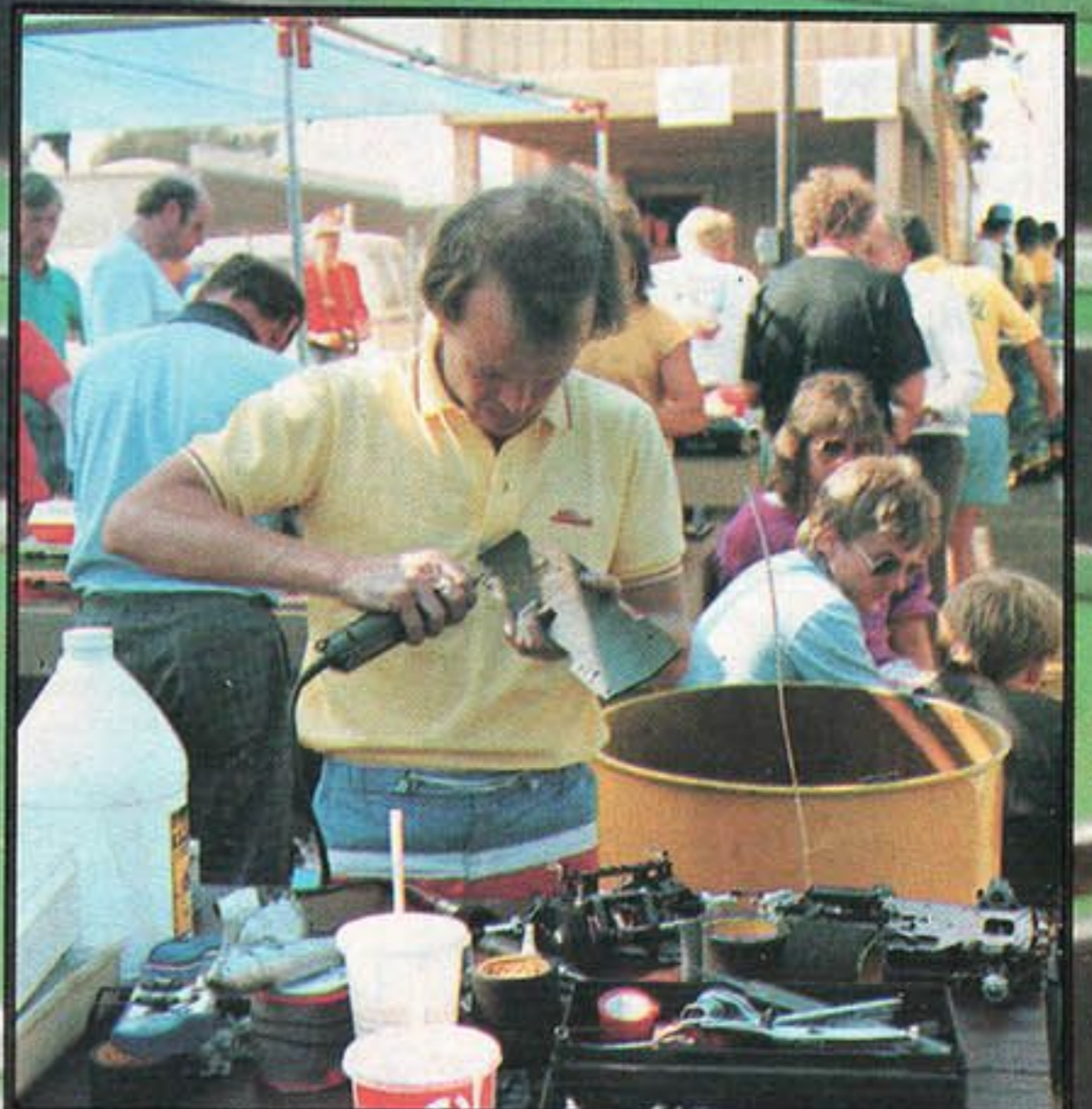
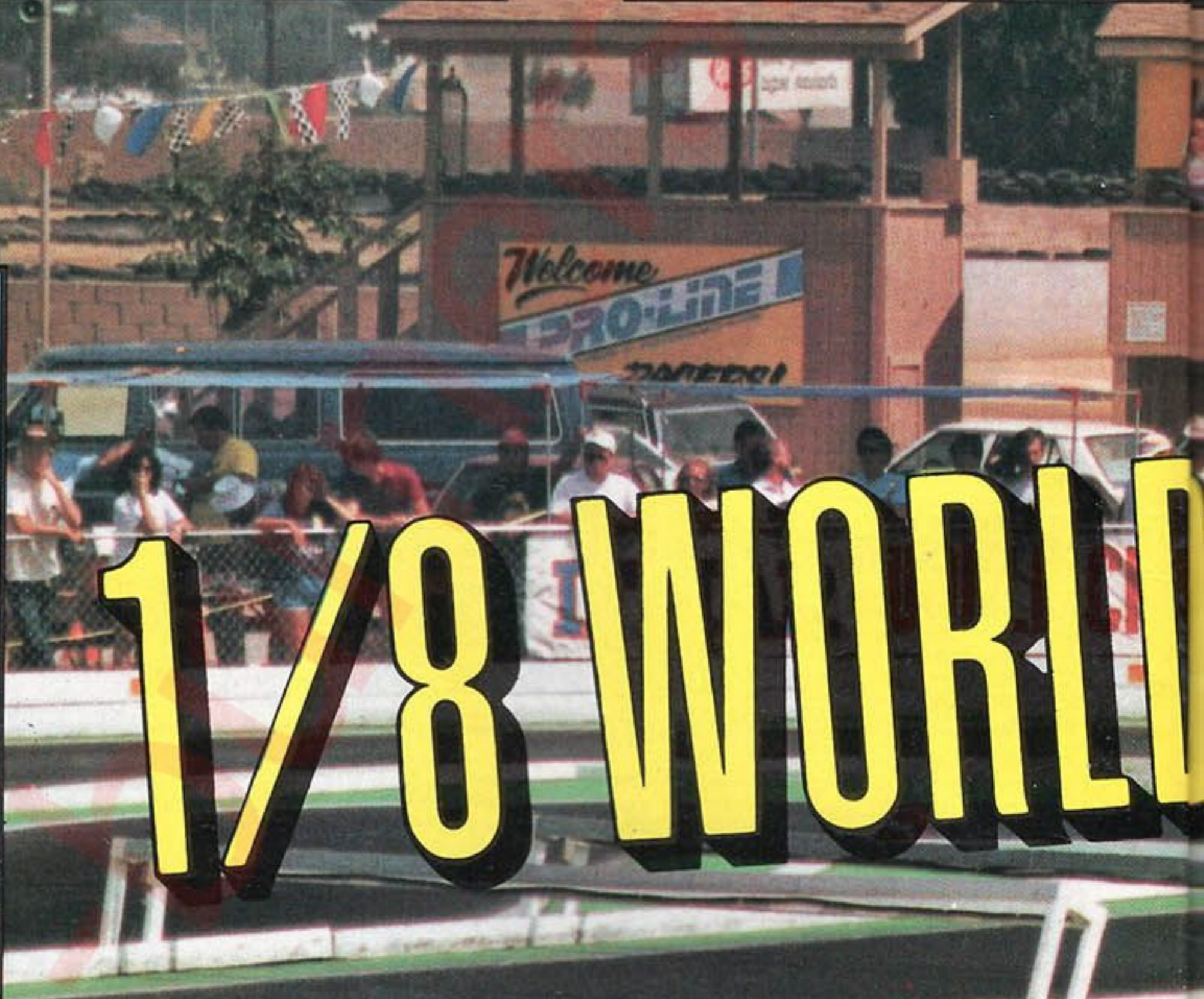
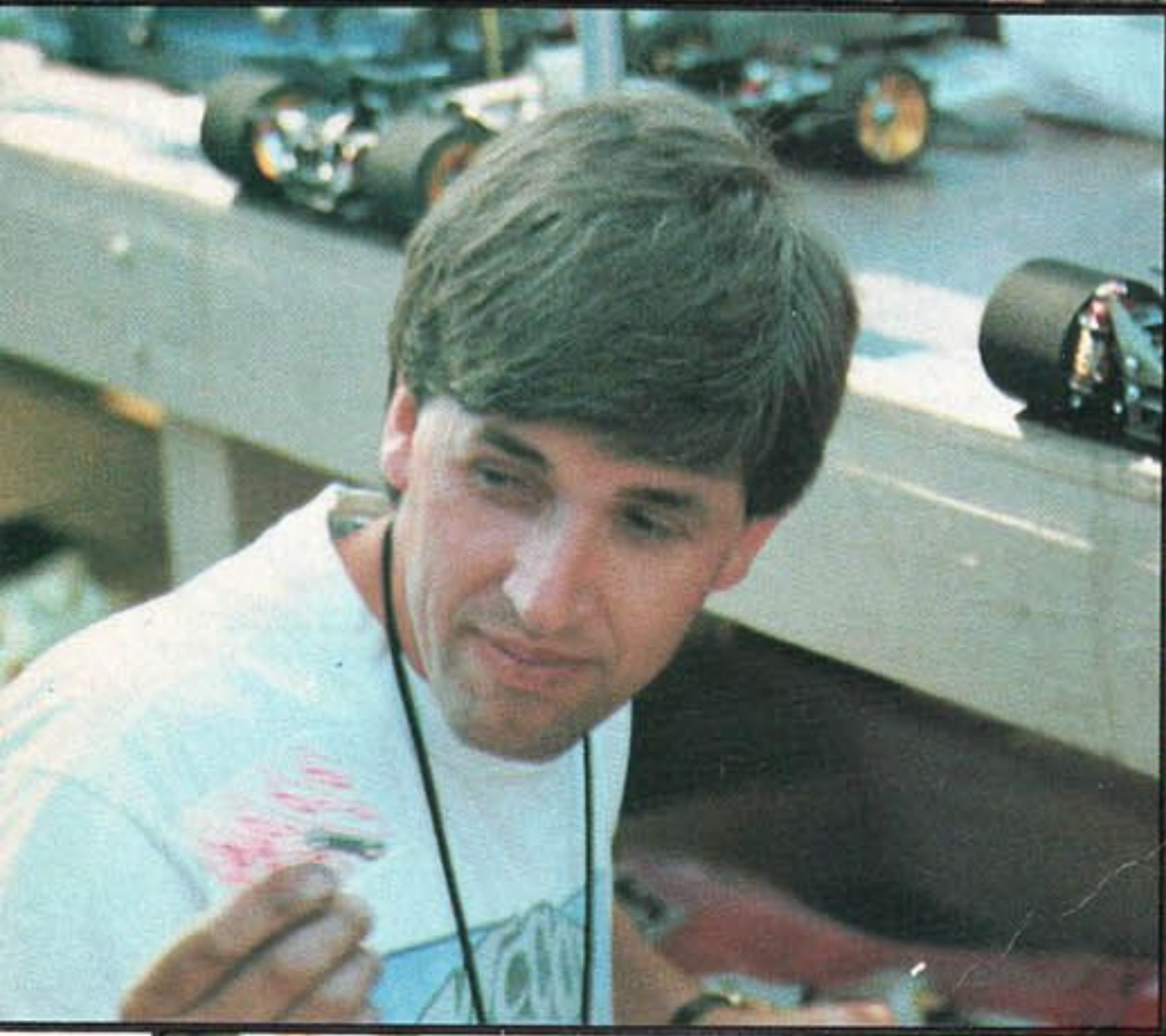
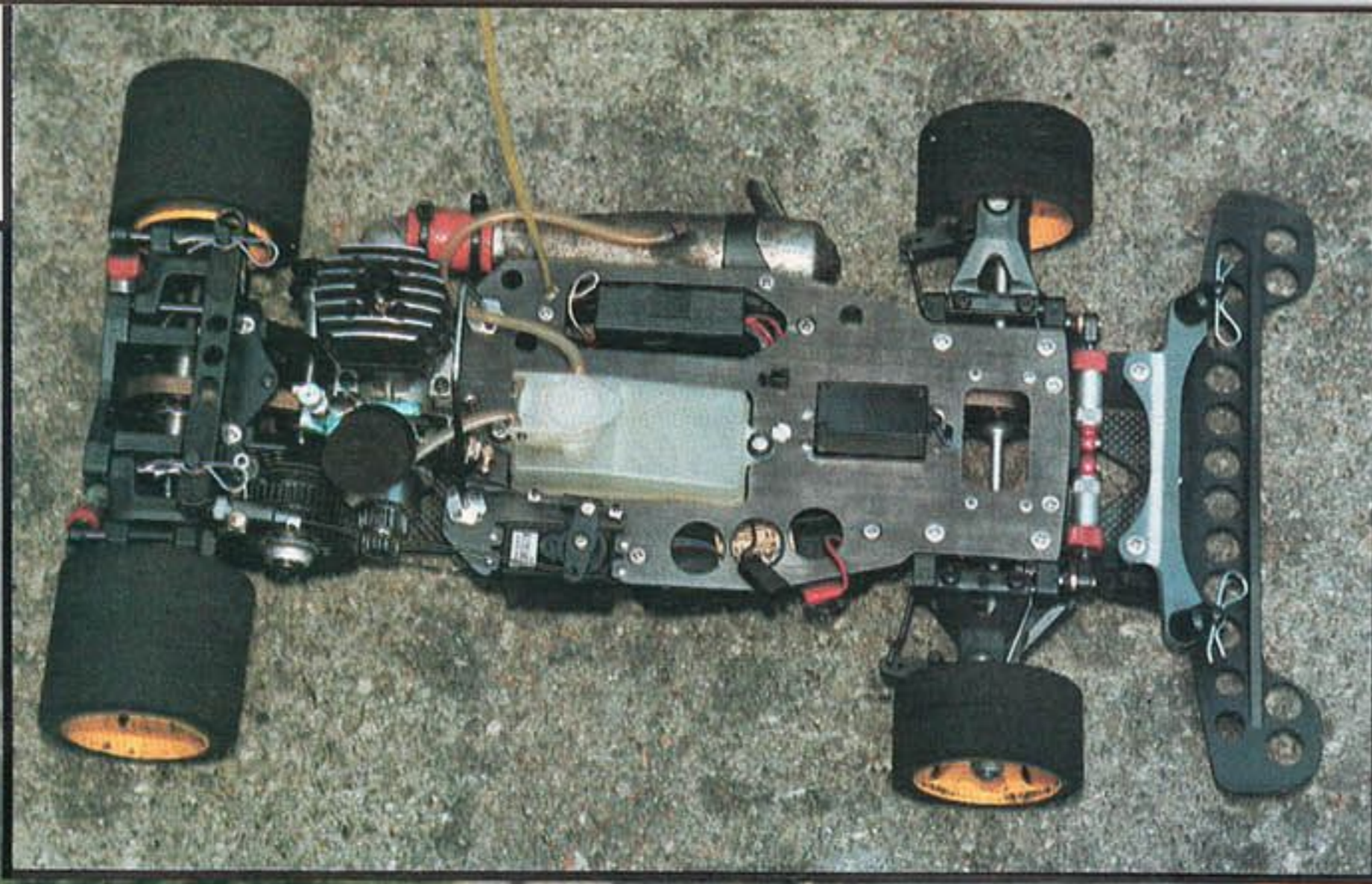



LAP 007  
DIF. 0  
DIF. 0  
TIMING 06

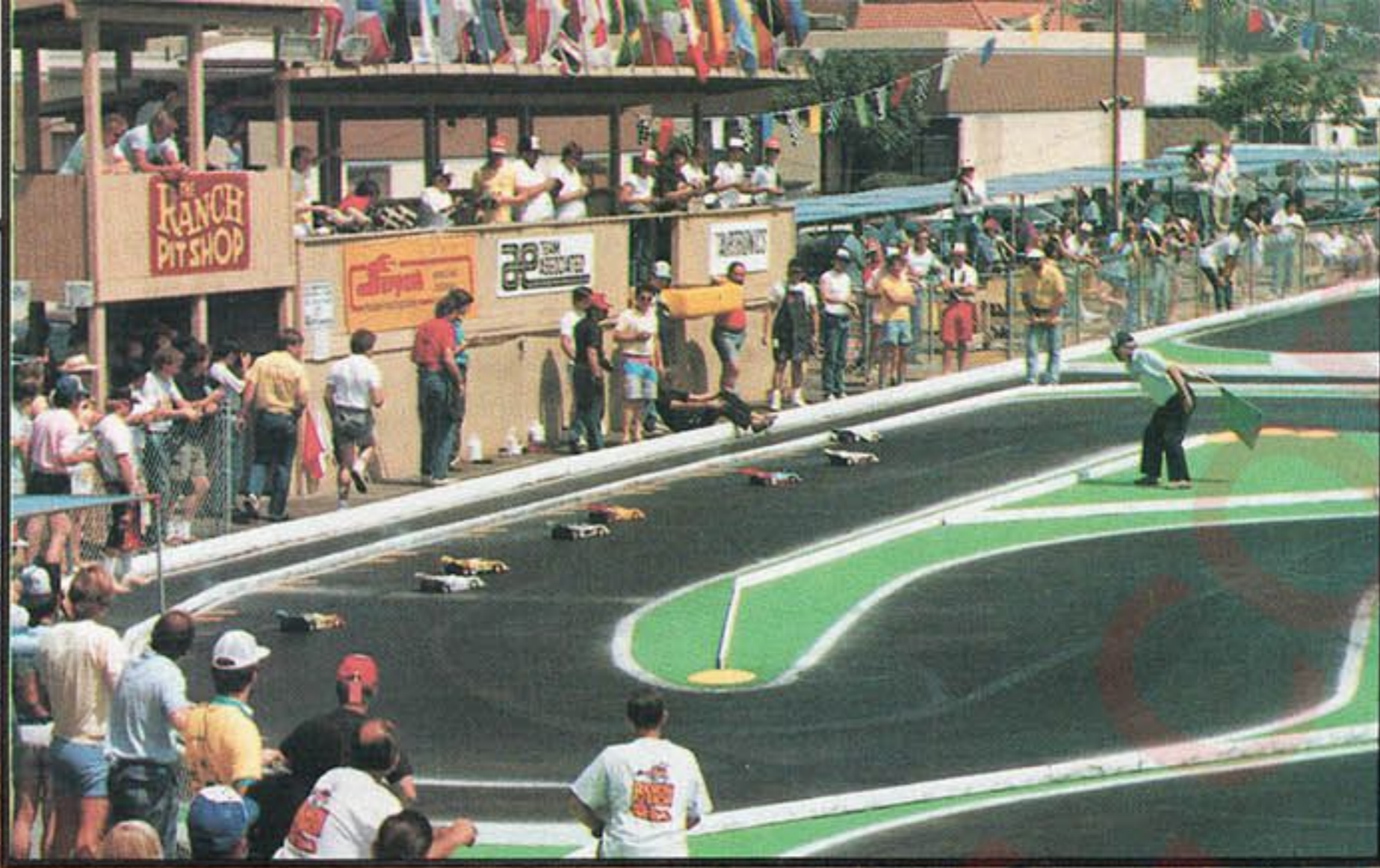

WELCOME RACERS!

CHAMPS

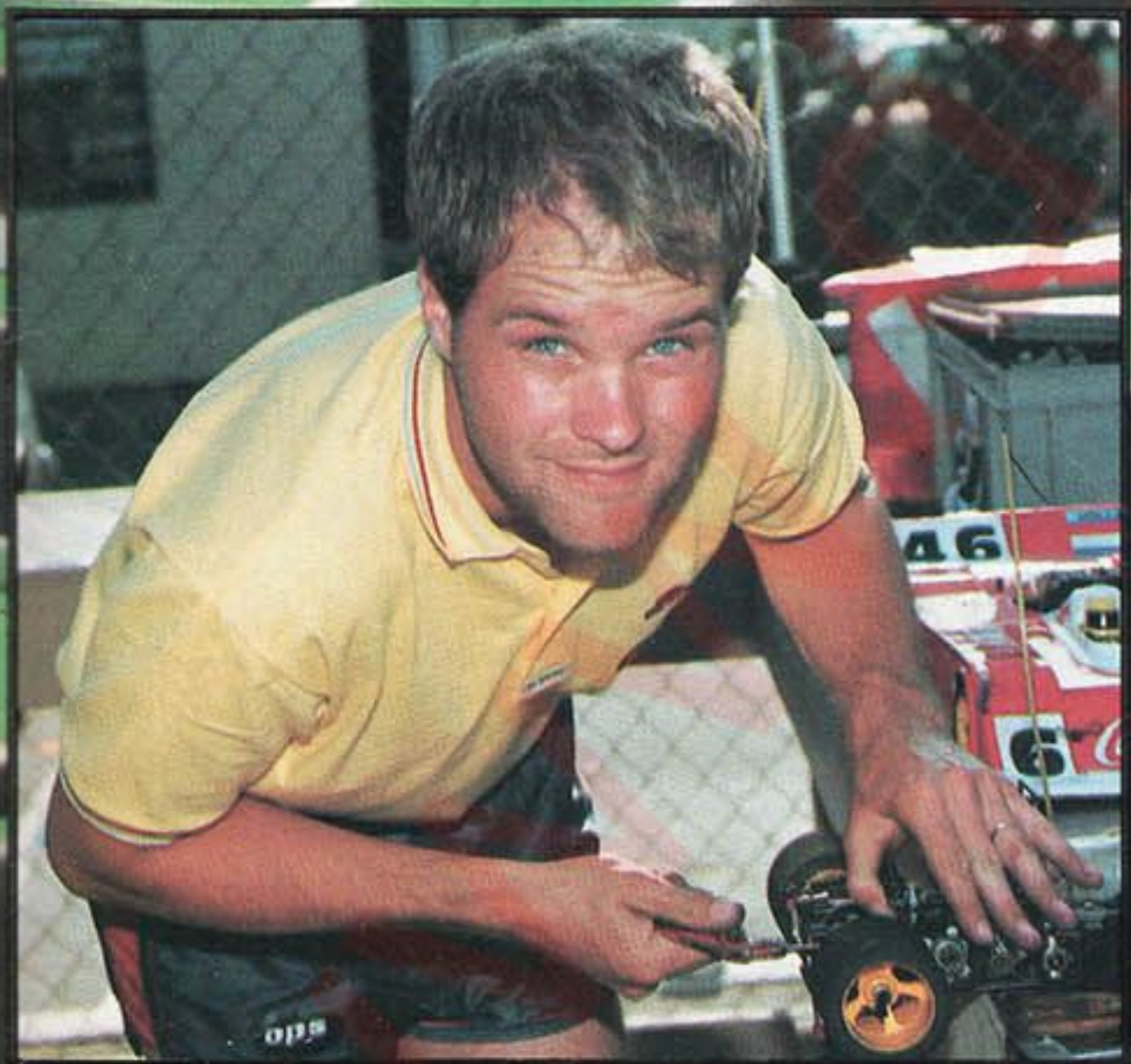

# GENE HUSTINGS reports from the 1/8 World Championships at Pamona.

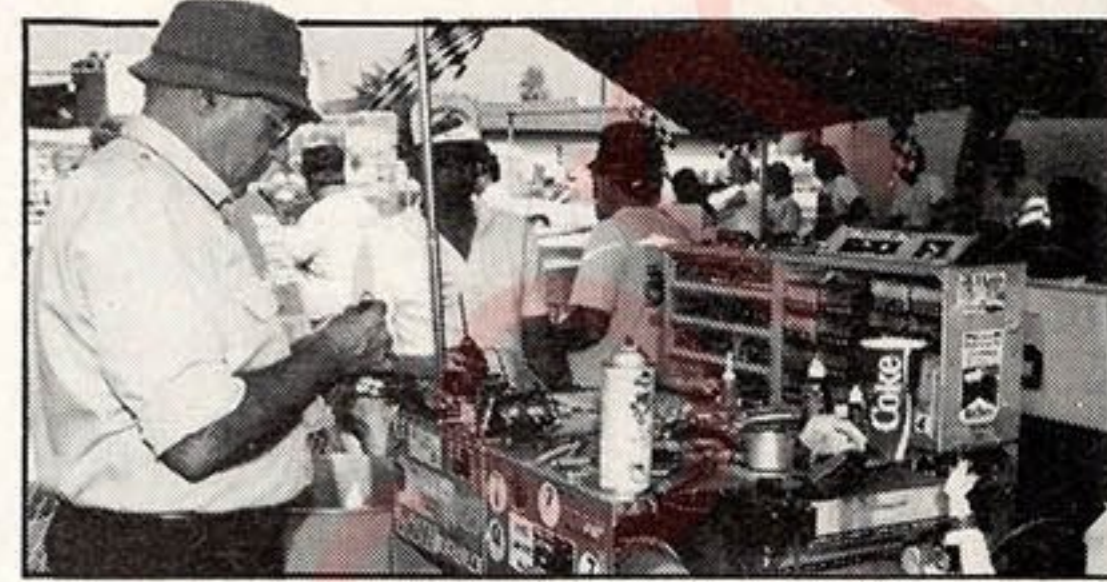

One Australian team member and his travelling box of tricks.

1. Gil Losi's car, finally set up and running perfectly.
2. All action in the pits and just look at the facilities available.
3. A section of the Pamona Raceway circuit.
4. The new 1/8 World Champion Re-Pete Fusco.
5. Trophy winners line up at the race banquet.
6. Rody Roem selects just the right part to rebuild his car with.
7. Gary Culver complete with drill threatens his car.
8. View of the circuit, look at the crowds!
9. Peter Bervoerts Mr Serpent himself in a pensive mood.

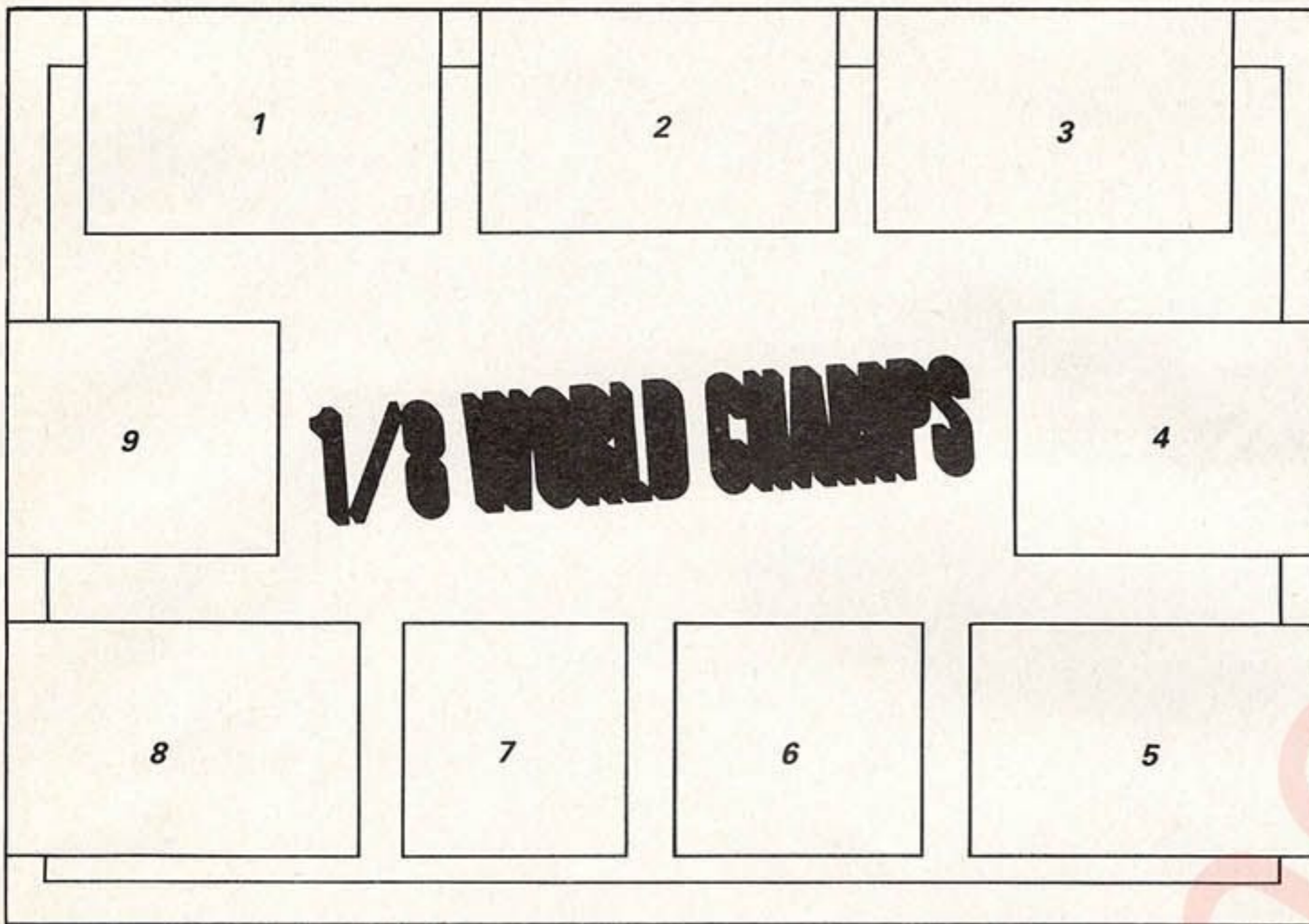

This year is the tenth anniversary of 1/8 scale World Championship racing time does fly, it only seems like yesterday that the first World Championship event was held right here on this track, then called Thorpe Raceway. Now the track is part of the Ranch Pit Stop and there have been a great many improvements made since the old days.

The 1987 1/8 World Championships would see 80 drivers competing from abroad and 40 drivers competing from the U.S.A. It seemed that the earliest drivers to arrive all came from Singapore, Ermes Tadiello, David Quek and Randy Swan arrived three weeks in advance and spent all that time practicing. Almost everyone else came with four days to spare. The Serpent team all arrived with lightweight cars, this caused a stir as only Roem, Ton, Berovoets and Hippe were supplied leaving Losi, Keyes Baehr and Bueler out in the cold. There was some explaining to do.

During practice it was impossible to pick favourites. Normally here in the U.S.A. four minute heats are used for qualifying, but for this race the qualifying heats were ten minutes long, which meant that you had to run five minutes plus on one tank of fuel. Now that, these days is getting hard to do, especially with 4wd cars, so during practice some cars were using carburettor restrictors.

There was a lot of motor testing taking place, the new S-Power being tried by the Serpent team, however they didn't race with it as they were still under contract with O.P.S. Mr Cesare Rossi was at the trackside complete with Piero Muio of O.P.S and Albert Picco of Picco motors. Our team, Associated were running 50/50 Mondial O.P.S. and Novarossi.

In all drivers from twenty one countries were taking part in the qualifying events, there were two rounds each day giving each driver six chances to do his best. At the start of qualifying traction was good and most drivers could not believe how long tyres were lasting. All qualifying heats were set up so that there was a mixture of nationalities in each heat. Finally the

weather a little cool, low 70° to 80°, at least 20° down on the norm.

### Wednesday

Wednesday was the first day of qualifying and the first driver to turn 35 laps was Ralph Burch Jr, he made a couple of mistakes so he knew he could go even faster. The next heat saw current World Champion Rody Roem turn an identical time of 35-10.16.8. On his next round Ralph ran out of fuel leaving Rody T.Q. F.T.D. honours. Barry Grossenbacher U.S.A. was third and Tony Neisinger U.S.A. fourth. Top four drivers all go through into the A Final.

### Thursday

The drivers rotas all swapped around now, that is drivers who ran in the morning yesterday run in the afternoon today. Thursday really saw times start to improve Burch timed 35-10.12.4 to take top spot and Gil Losi Jr turned 35-10.13.9 to take second. Gil had been struggling for a year to get the car just right, it seemed today he finally managed just that.

A new starting system was used in qualifying for the first time in the U.S.A., with each cars time starting when they start their first lap or as they cross the transponder line to be exact.

What this means is that as the countdown gets to three the cars may start and may continue to start until the first car away recrosses the line. This idea eliminates the first corner melee.

Losi and Roem knew exactly how to work this system to their best advantage, at the countdown Rody took off with an empty track in front of him, Gil waited until Rody was three quarters of a lap clear and then went, this allowed both of them to go very fast without getting in each others way. In the end Gil had just beaten Burch's time and turned 35-10.12.0 to take over top spot. Eventually qualifying finished and places looked like this.

### The Top 18 Qualifiers

Driver	Country	Time
1 Gil Losi Jr	USA	35-10.12.0
2 Ralph Burch Jr	USA	35-10.12.4
3 Rody Roem	Holland	35-10.15.8
4 Tony Neisinger	USA	35-11.18.2
5 Barry Grossenbacher	USA	34-10.05.2
6 Gary Kyes	USA	34-10.07.1
7 Dana Smeltzer	USA	34-10.09.2
8 Jakob Bueler	Switzerland	34-10.10.3
9 Butch Kloeber	USA	34-10.11.5
10 Repete Fusco	USA	34-10.11.7
11 Gary Culver	England	34-10.13.8
12 Domenico Calce	Italy	34-10.14.8
13 Juegen Baehr	West Germany	34-10.15.1
14 Curtis Husting	USA	34-10.17.3
15 Michele Baruzzi	Italy	34-10.17.5
16 Sinichi Yamaguchi	Japan	34-10.17.7
17 Stewart Grant	Australia	33-10.01.6
18 Ron Rossetti	USA	33-10.01.7

### First Semi Main

Driver	Country	Laps	Car	Motor
1 Barry Grossenbacher	USA	100	Associated	Novarossi
2 Butch Kloeber	USA	96	Associated	Paris-Mondial
3 Albert Grob	Switzerland	94	Serpent	OPS
4 Jurgen Baehr	West Germany	94	Serpent	Mondial
5 Stewart Grant	Australia	92	Serpent	Novarossi
6 Roger Sahli	Switzerland	90	SG	Rossi
7 Gary Culver	England	89	Serpent	Novarossi
8 Dana Smeltzer	USA	34	Associated	Novarossi
9 Michele Baruzzi	Italy	18	—	—
10 Michael Salven	West Germany	11	Serpent	Mondial



**First Semi Main**

The first semi saw Barry Grossenbacher jump into the lead with only Dana Smeltzer keeping in touch, Butch Kloeber was in third. After the second pit stop Dana came out of the pits and was hit, knocking his silencer off. Barry was still flying a clear two laps ahead of Kloeber, eventually Barry was four laps ahead and finished by turning 100 laps.

**Second Semi Main**

Gary Kyes went straight into the lead from his number one position on the grid with Curtis Husting right behind him and Repete Fusco in third. After the first few laps Repete passed Curtis with Ron Rossetti in hot pursuit, by this time Repete was flying and passed Kyes who clipped a dot and lost a pin from the rear end of his car. The race ended with Repete winning from Rossetti in second and Curtis in third.

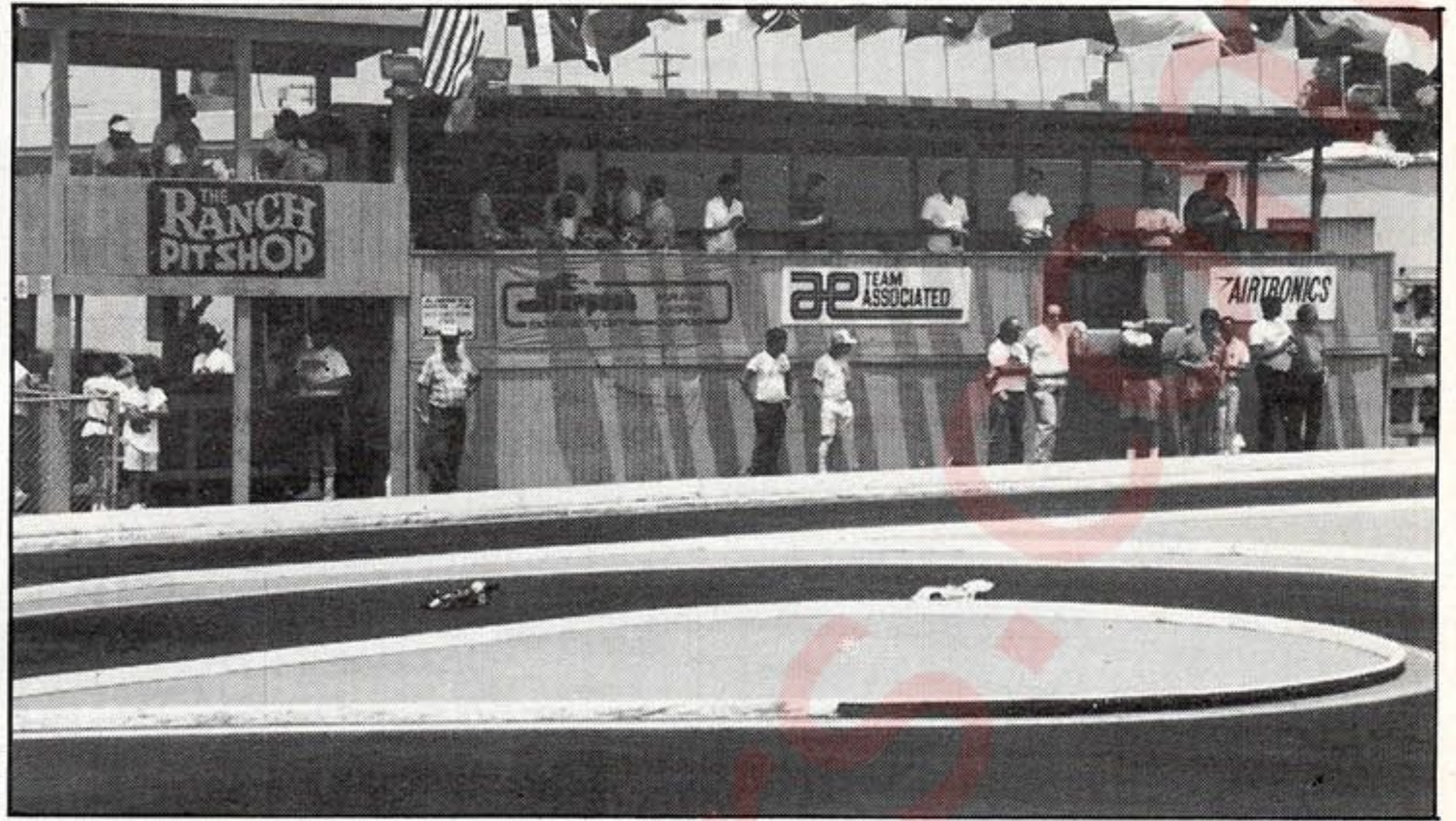

Above, the drivers rostrum what a great place Pamona raceway is, complete even with workshops housing metalwork machinery.

Driver	Country	Laps	Car	Motor
1 Repete Fusco	USA	98	Associated	O'Donnell Novarossi
2 Curtis Husting	USA	97	Associated	Paris-Mondial
3 Ron Rossetti	USA	97	Serpent	Paris-S
4 Kevin Mercandante	USA	97	Serpent	Paris-S
5 Hernan Matticoli	Argentina	94	Mantua	Picco
6 Domenico Calce	Italy	86	Serpent	Novarossi
7 Maurizio	Italy	85	Serpent	OPS
8 Gary Kyes	USA	83	Serpent	Paris Mondial
9 Jakob Buehler	Switzerland	80	Serpent	OPS
10 Sinichi Yamaguchi	Japan	6	Serpent	—

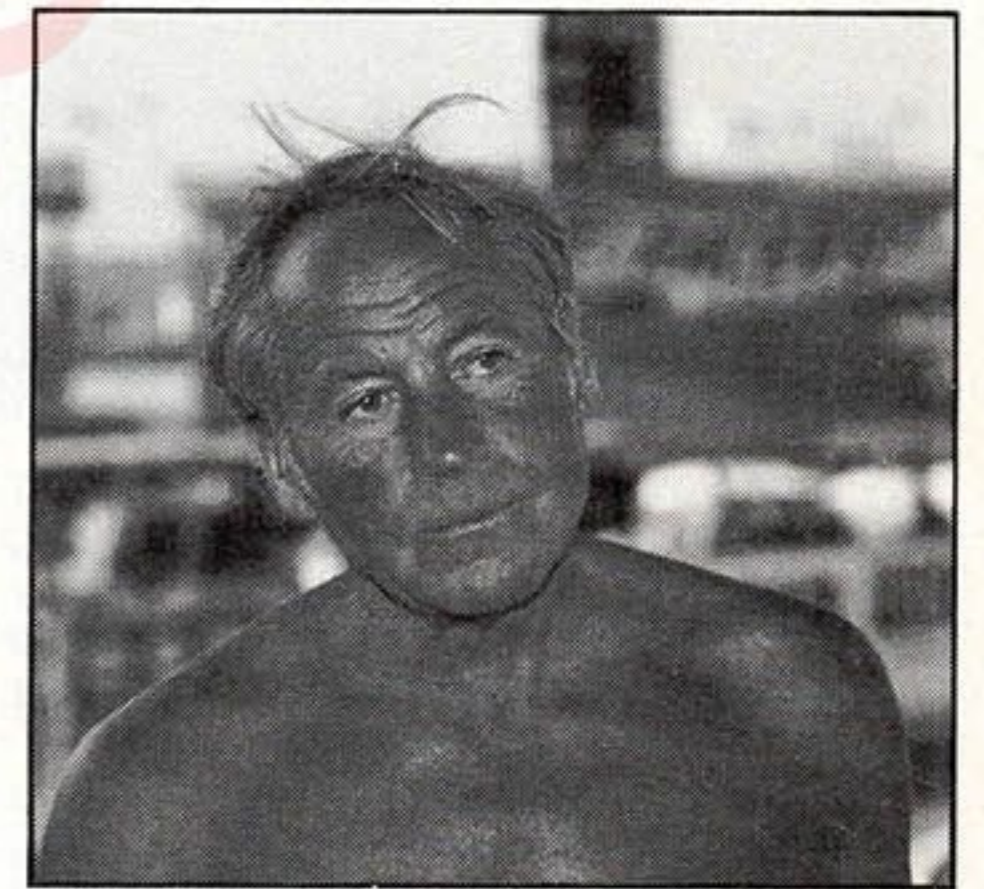

Ted Longshaw Mr Racing himself enjoying the meeting and the Californian sunshine.

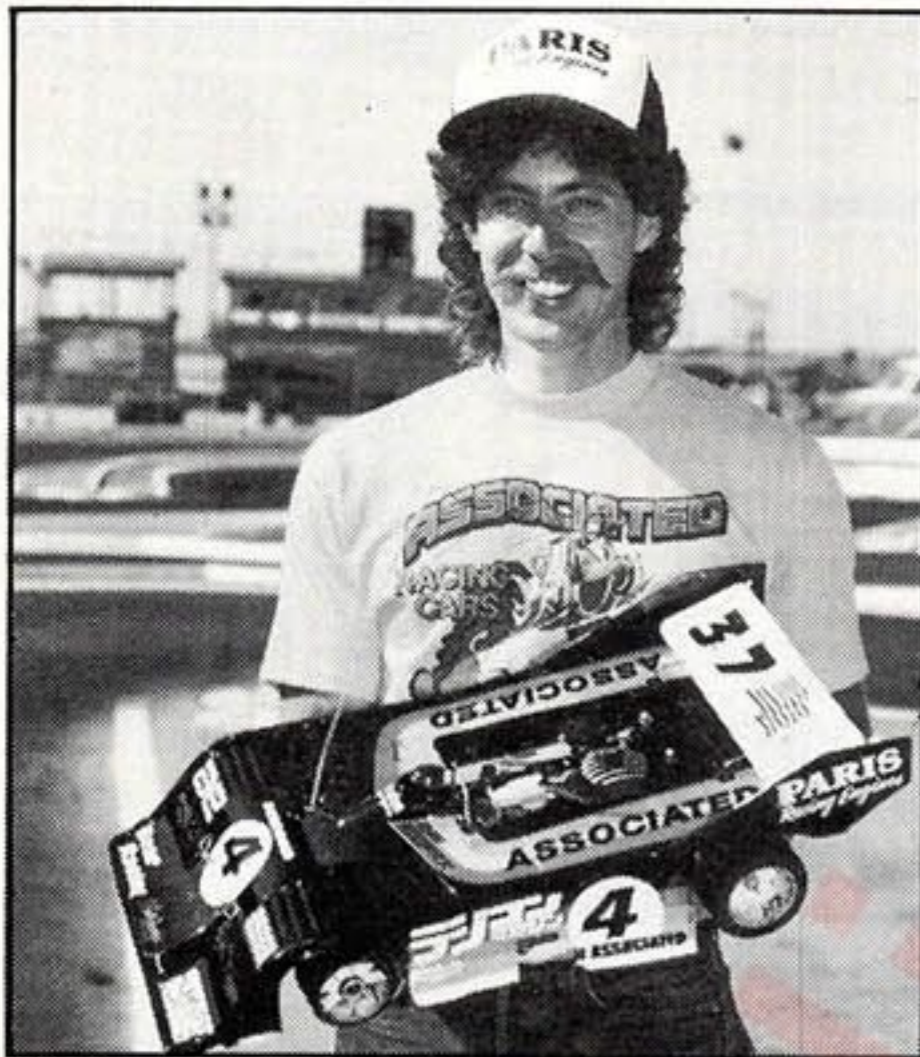

Above, Tony Neisinger and his Associated, below Kevin Mercandante holds his Serpent.



**Final**

Sunday was perfect, temperature was a steady 85° and the crowd was huge. The day started with a twenty minute practice session, finally the cars were called to the line for a Le Mans type start, the horn sounded and away they went. Gil Losi Jr took the lead followed by Ralph Butch Jr. Rody Roem, Barry Grossenbacher, Curtis Husting and Butch Kloeber.

Grossenbacher's car was the fastest on the track but it didn't seem to have any brakes, he came up on Burch too fast and hit his rear tyre causing a crash that only Grossenbacher drove cleanly away from.

Five minutes and time for the first pit stop, Losi and Burch pull in together and Burch's pit stop is much faster allowing him away first but he lost the car and spun into a wall, losing a wheel. So coming out of the pits it was Losi, Roem, Husting and Grossenbacher.

By this time Grossenbacher in fourth place ran out of fuel and pulled out of the pits again behind Roem catching him at the start of the long straight. Neck and neck they turned into a corner and touched, Roem's car appeared to be having some

steering problems after that tangle, a short while later Roem dropped out, his engine blown.

Gil was now in the lead by about a quarter of the track with Repete catching by about three seconds every pit stop, thanks to Steve O'Donnell's skill.

Losi started to run into problems now, first running out of fuel and his two speed locked in first gear for some time. By now the race order was Repete, Mercandante, Neisinger and Curtis with Losi challenging him for his fourth place. Time after time the two tangled for fourth place, the crowd loved it, but for Losi, all to no avail as that's how the race finished.

Driver	Country	Laps	Car	Motor
1 Repete Fusco	USA	195	Associated	O'Donnell Novarossi
2 Kevin Mercandante	USA	188	Serpent	Paris-S
3 Tony Neisinger	USA	181	Associated	Paris Mondial
4 Gil Losi Jr	USA	174	Serpent	Paris Mondial
5 Curtis Husting	USA	174	Associated	Paris Mondial
6 Rody Roem	Holland	153	Serpent	OPS
7 Ralph Burch Jr	USA	143	Associated	Paris Mondial
8 Barry Grossen	USA	116	Associated	Novarossi
9 Ron Rossetti	USA	102	Serpent	Paris-S
10 Butch Kloeber	USA	61	Associated	Paris Mondial



# Vanessa's LUNCH BOX

When you hear of people wishing that they could 'crush the opposition', they might now be in a position to actually do that with this 1/12 scale American Dodge Van, known affectionately as Vanessa's Lunch Box.

This outrageous machine runs on huge 115 millimetre diameter tyres, imagine that on a full scale model. With an overall height of 225 millimetres, the full size again twelve times taller, needs a fair sized ladder in order to enter the cab.

This style of customized vehicle does not lend itself to racing, but it certainly is an eye catcher at shows and offers immense pleasure when shown off to friends and family around the garden or paddock.

Tamiya are world renowned for their range of kits. No nonsense cars that are simple to build and run, good spares availability and pleasing modern designs.

The 'Lunch Box' is no exception to Tamiya's standards and thus deserves a closer look from ourselves.

The kit is based around a single,

**JOHN VARLEY** looks at the latest 1/12 car crusher from Tamiya.



**All electrics are kept neatly out of the way inside the bathtub chassis.**

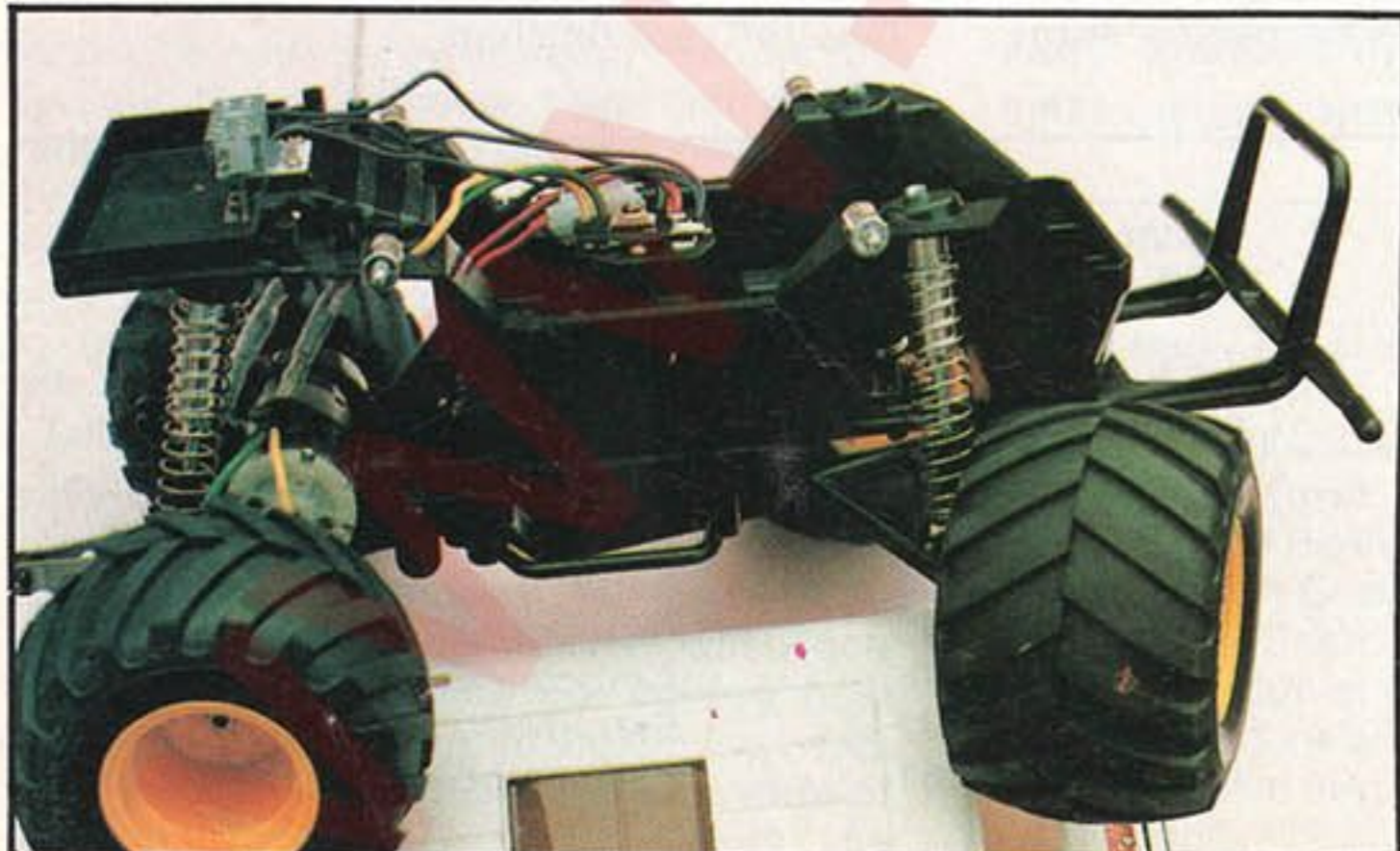

**Strong solid construction makes this car crusher a low maintenance vehicle that will give hours of fun.**

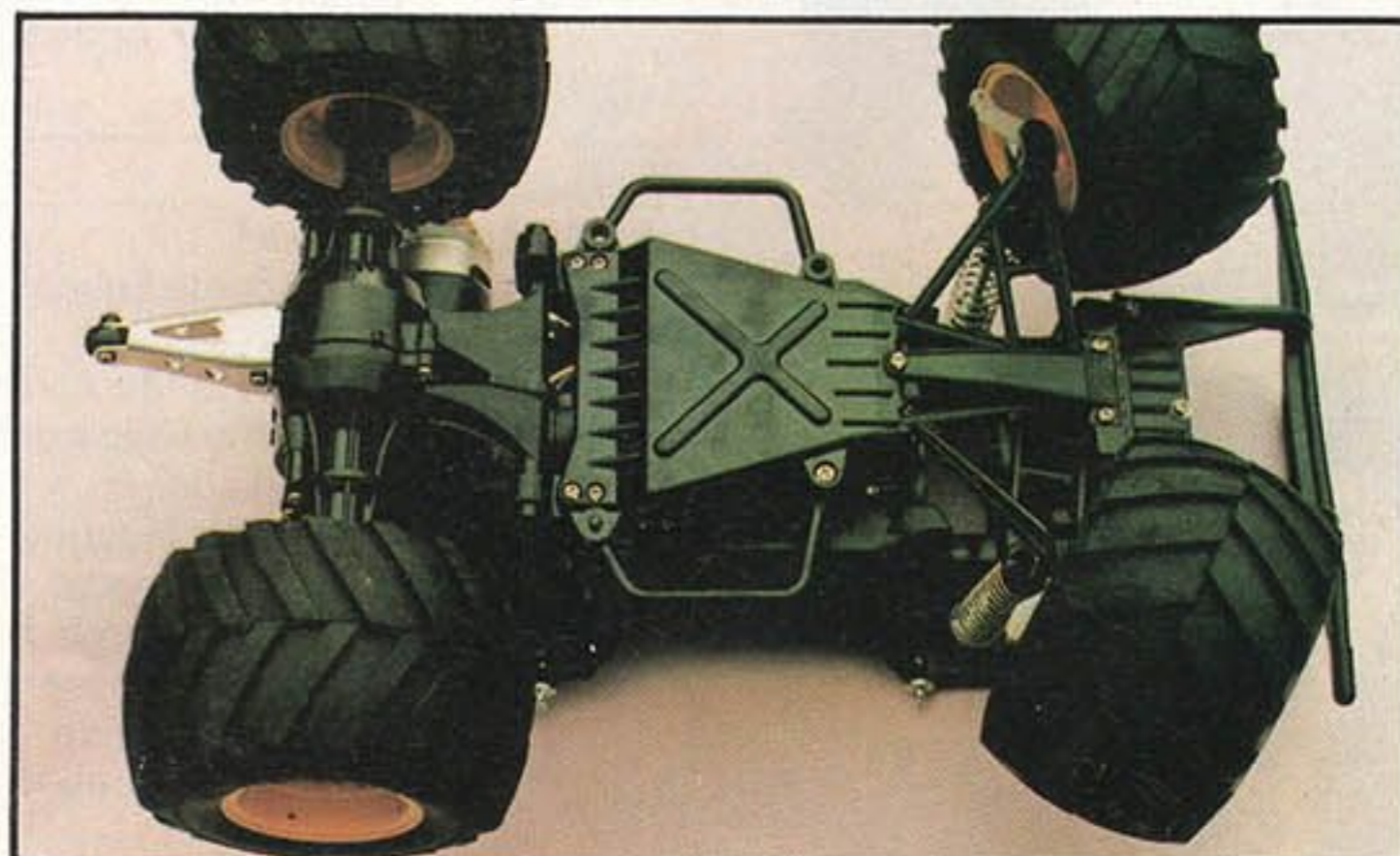

moulded, bathtub type chassis with all the necessary provisions for radio installation, kit speed controller and battery installation.

The rear wheel drive is through a moulded gearbox. Traditional straight cut spur gear with nylon bevel gear differential, housed in a centrally split gearbox moulding. The moulding incorporates nylon bushings, easily replaced at a later date with ballraced for the drive shafts to run in.

This rear drive assembly swings via moulded pivots, attached to each side of the main chassis moulding; with large chrome plated coil spring assemblies, that can be replaced with upgraded oil filled shock absorbers, sold as bolt on extras.

The front has independent suspension, with single swing arms, with identical coil spring assemblies as at the rear, offering the necessary ride height. Full ball jointed track rod assemblies are provided with a range of servo savers to suit all modern servos currently used.

Protection from frontal crashes comes via a reinforced special resin bumper, whilst at the rear the car is provided with a neat bracket and roller to retain it when doing those wheelies common to this style of kit.

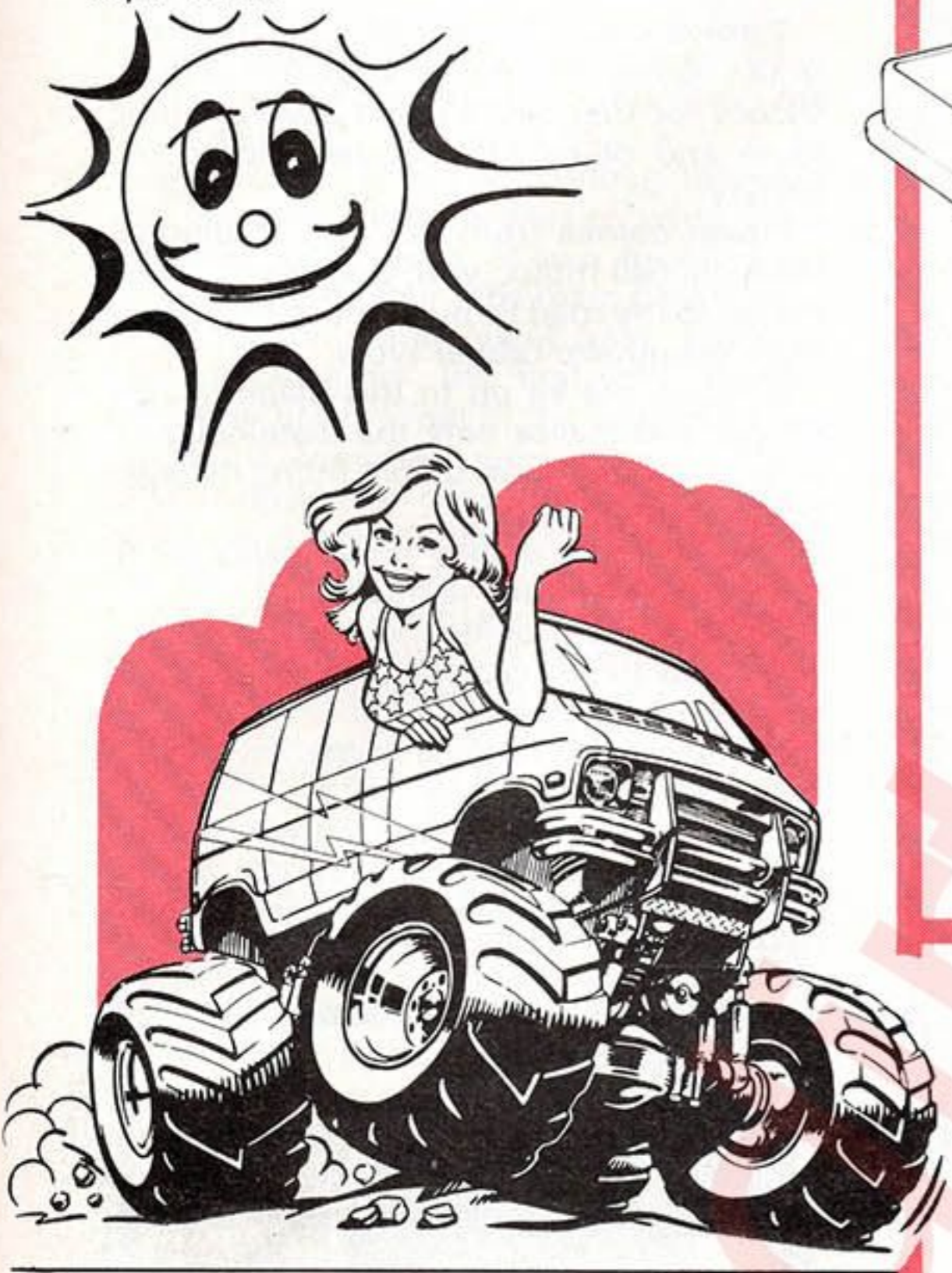
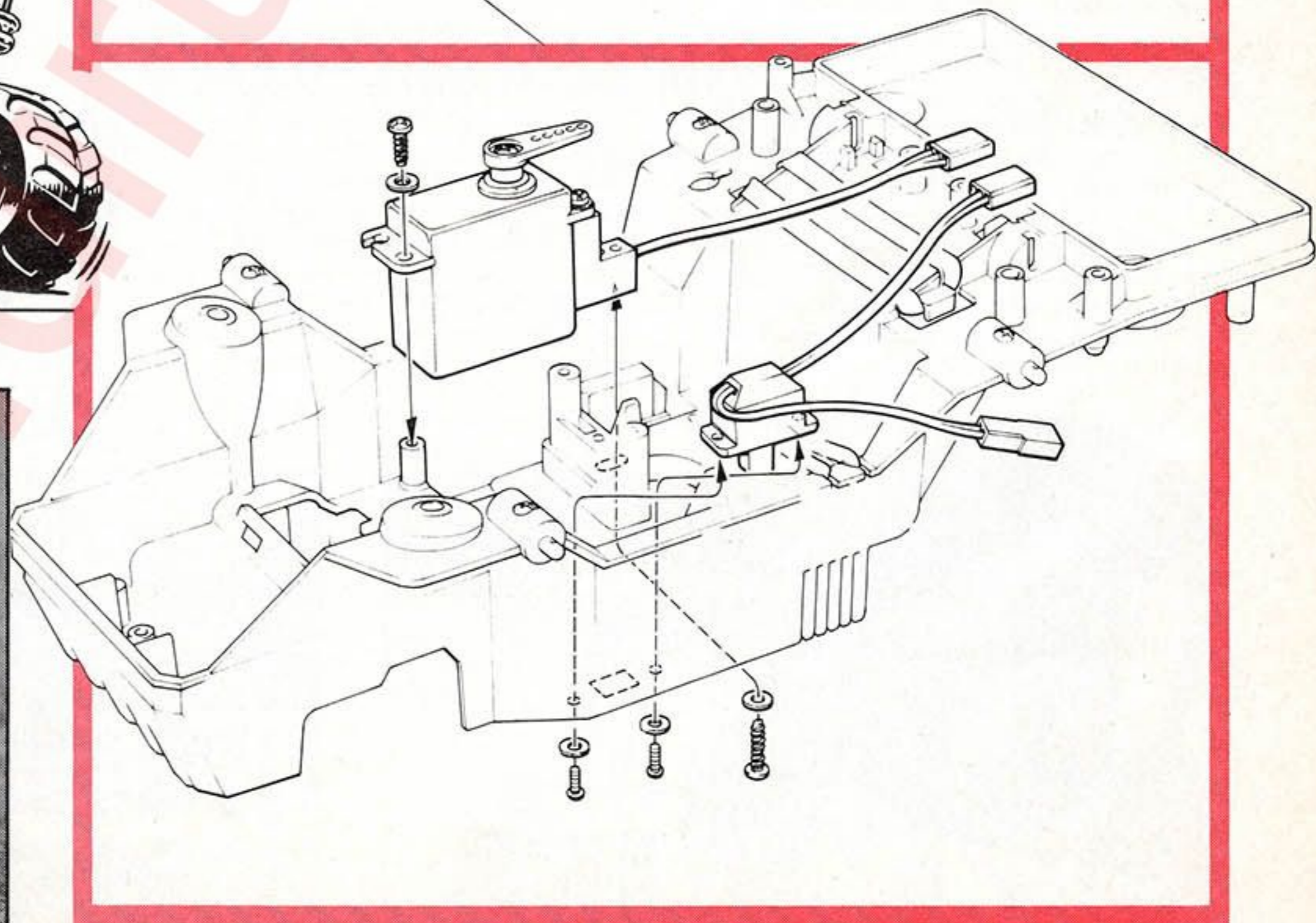
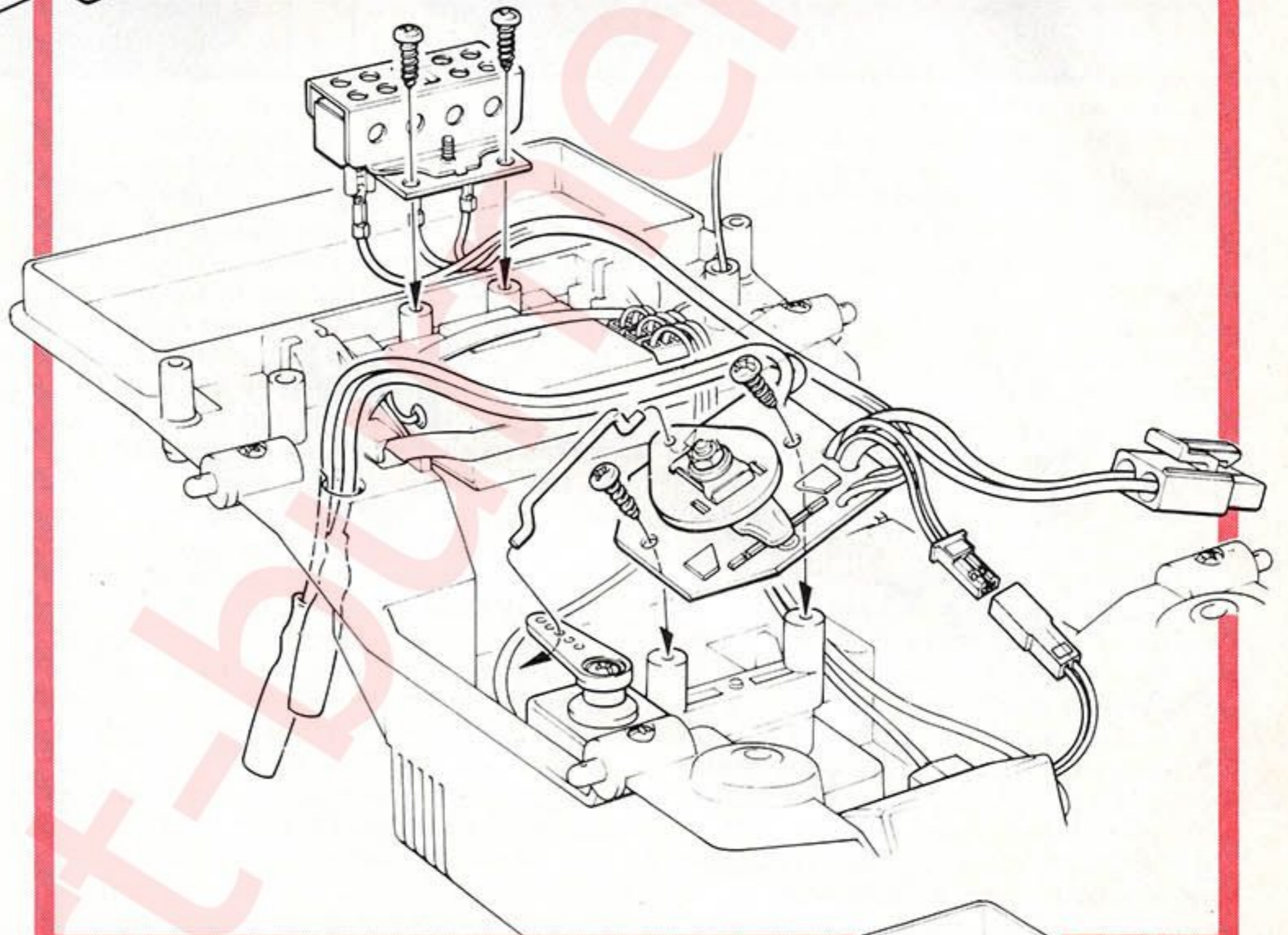
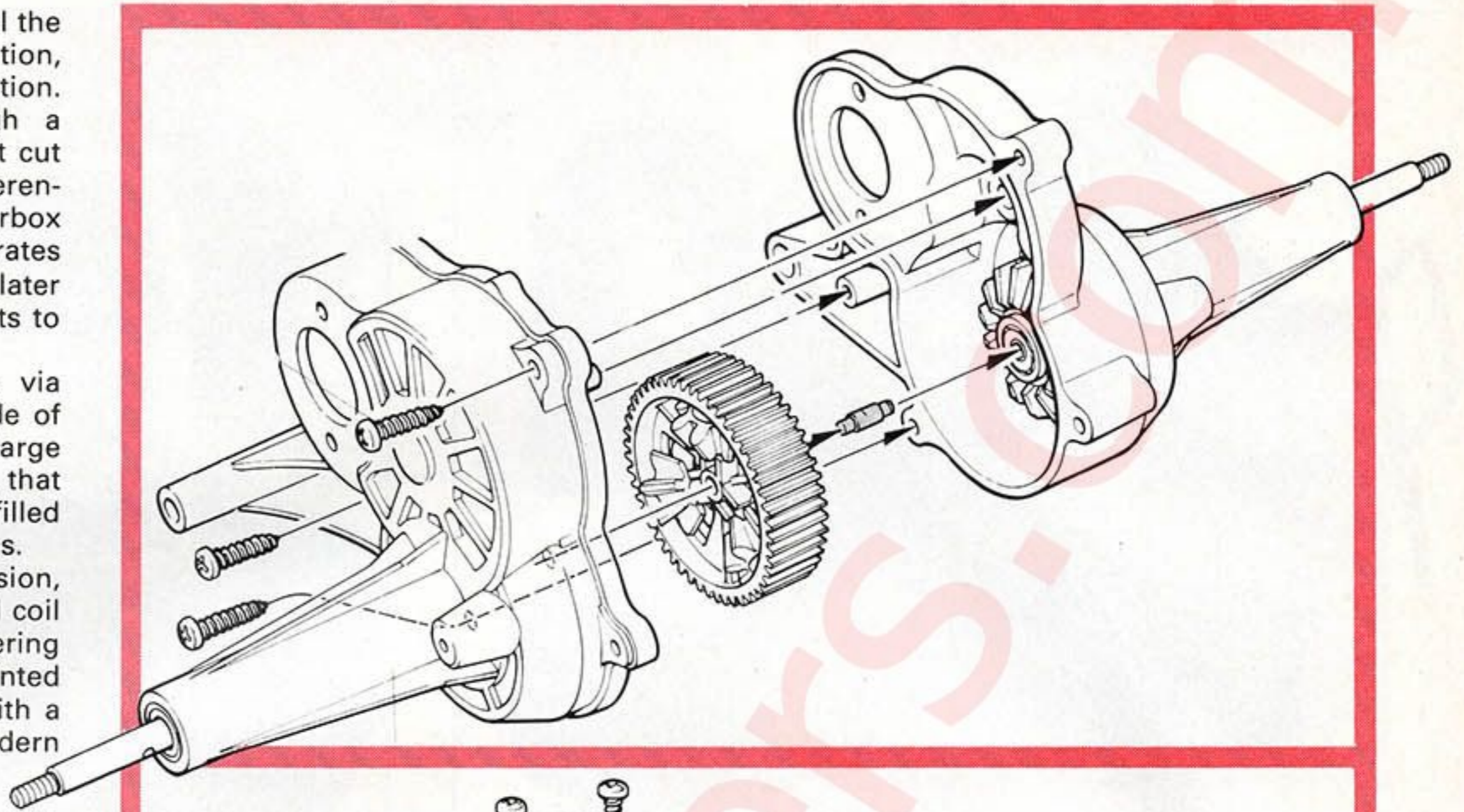

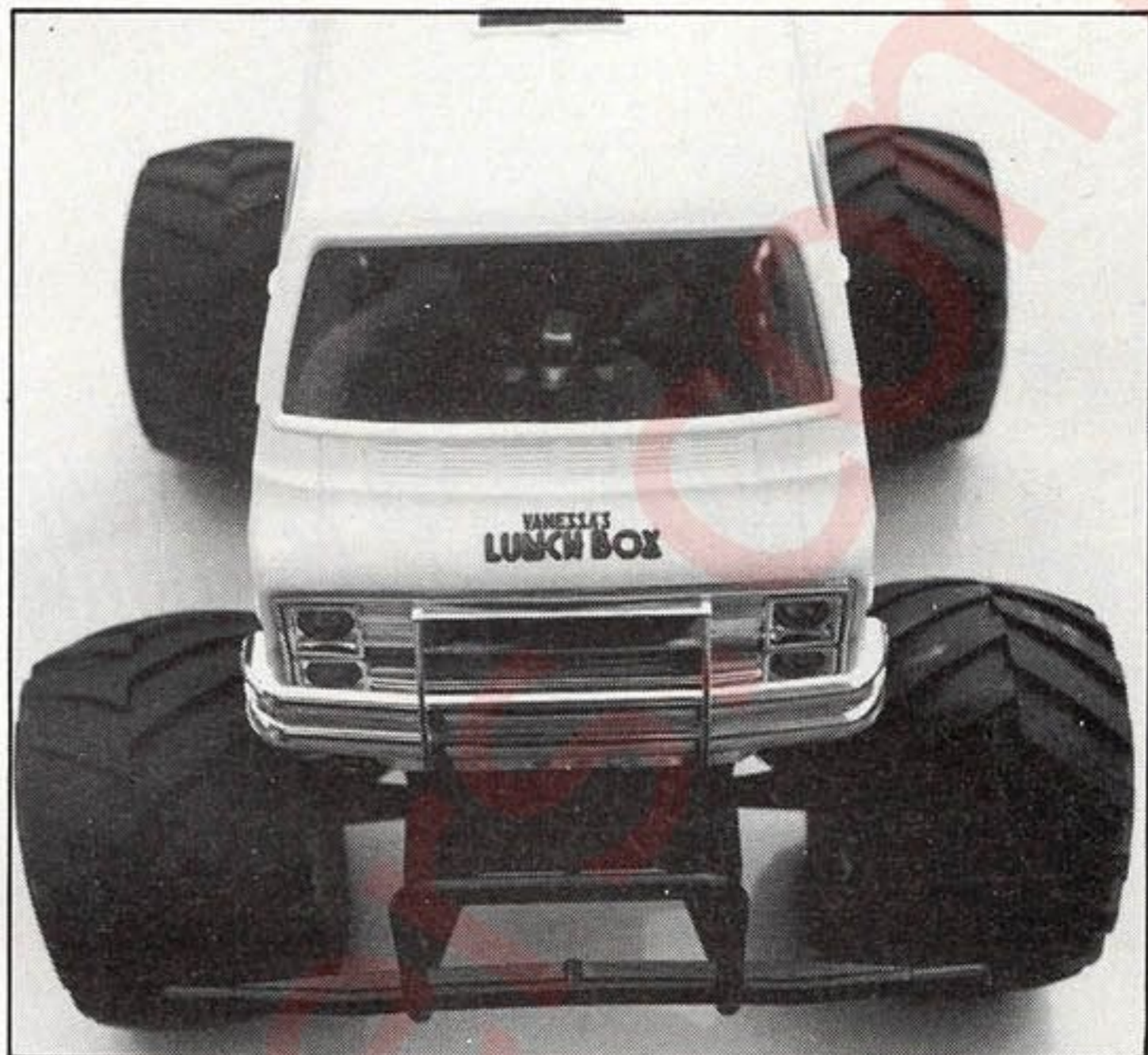
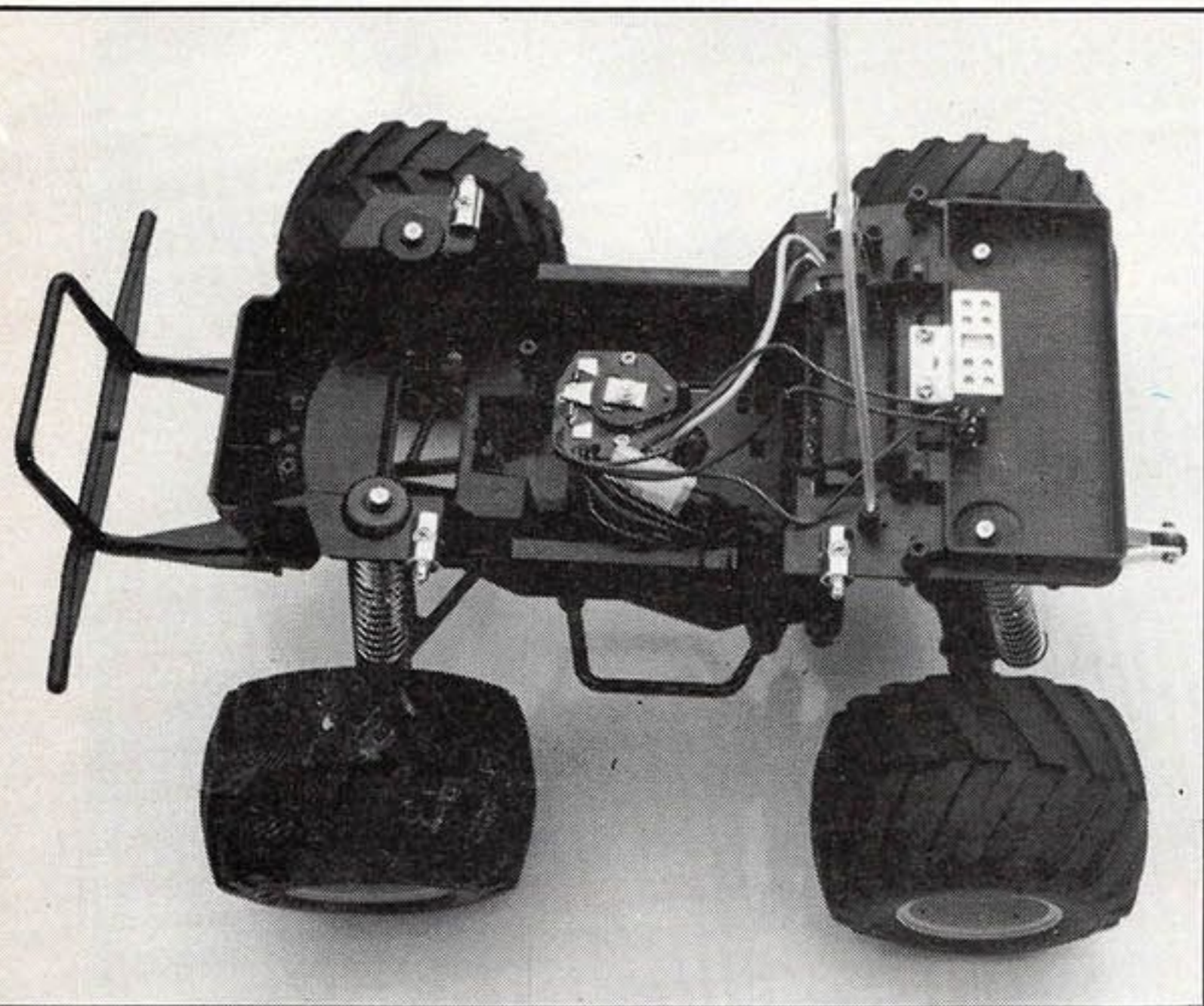

Tamiya's well known three speed controller comes with the kit, provided with resistors for first and second speed, wiring loom and plugs for receiver, motor and battery.

Power comes from the now traditional Mabuchi 540 motor, with that power transmitted to the road through those enormous semi pneumatic rubber tyres.

Building the kit up to this stage is very simple and leaves only the installation of your own radio gear, before fitting the high quality moulded body.

The 1/12 scale is only given away when the Dodge van body is fitted.

The body is moulded white and can be sprayed with any car cellulose spray to suit your own colour scheme, finished off with those excellent Tamiya decals portraying 'Vanessa's Lunch Box'.

To finish off the illusion, chrome plated grille, bumpers and side exhausts are fitted, along with tinted glass windows and roof skylight.

A traditional starter kit for youngsters, well made and easy to assemble, it offers hours of fun to run and satisfaction to build.

Very little can go wrong and therefore little to replace in the long term. With some original thought it could be made into a real eye catcher for shows and concours.

Available from all Tamiya stockists. Price approx £65.00.

# Bob Errington's PIT PATTER

Well, first thing to do this month is to congratulate Nigel Sayles who becomes the first Englishman to win the European Youth Championships. This event was held in Sweden, at the Staffanstorp circuit in mid July, in what could only be described as diabolical weather conditions. At one stage a fire engine had to be called to pump away the flood waters.

Nigel qualified his Nova Rossi powered S.G. Space in third position on what was a foreshortened series of two heats, there normally being four. The main final started in heavy rain and Nigel held a steady second place for the first few minutes whilst he got the feel of the conditions. As his M.R.C. tyres were working well, he was able to close in on the leader and pass him, to take and hold the lead for what seemed like an eternity with the rain blowing into the face of the rostrum. However, 25 minutes passed and Nigel, who was now a full lap up on second place, duly collected the winners accolades. So in a language he will understand:- "Now then — Well dun son!"

Meanwhile back in England we were enjoying a typical summers day at Wrexham in North Wales, i.e. it was absolutely pouring with rain. Now this year we thought we had the weather beat by scheduling the Wrexham meeting for early August, and then, only a short time before, swapping the date with Aldershot albeit for reasons outside our control, only to find the weather had sussed this move and stored all the rain up just to make sure.

Many people today are prepared to run in such extreme conditions, especially

when they know that a set of M.R.C.'s fabulous wet weather tyres will give them superb grip in the wet. Mind you the damp, and or drying track does present different problems! Radio receivers are usually well packed with silicone grease, but don't tell the manufacturers agent! And some really ingenious air filters are now to be seen growing out of the carburettor. All in all it means that one can have good even races on equal terms. The big drawback though is the amount of work that has to be done afterwards to get all the rust out of the bearings and the grit from the suspension pivots etc., not to mention the ingress of water into the motor itself. Frank Chung from London was actually seen washing his car down in a large puddle after a days wet weather racing — presumably to wash the water out?

Thirty one brave souls faced the conditions on the Saturday with many more electing to wait for it to dry out, ha! ha! P.B's seem to go well in the wet at Wrexham and it was Shaun Jackson who took the F.T.D. with 19 laps in five minutes six seconds just two seconds ahead of Neal Woodheads Serpent and Chris White's new prototype PB X6 (the same as Paul Pagdins seen in last months issue) and dad, Mike Jackson, just missed the open with his P.B. by a few seconds.

The formula open final didn't last long for Steve White though, as he retired with just one lap on the counter, so too did Neal Woodhead, also with one lap. Colin Straus was next out at quarter distance and then just before the halfway mark Chris White also retired after having led early on. This left Steve Fletcher from the Wrexham club

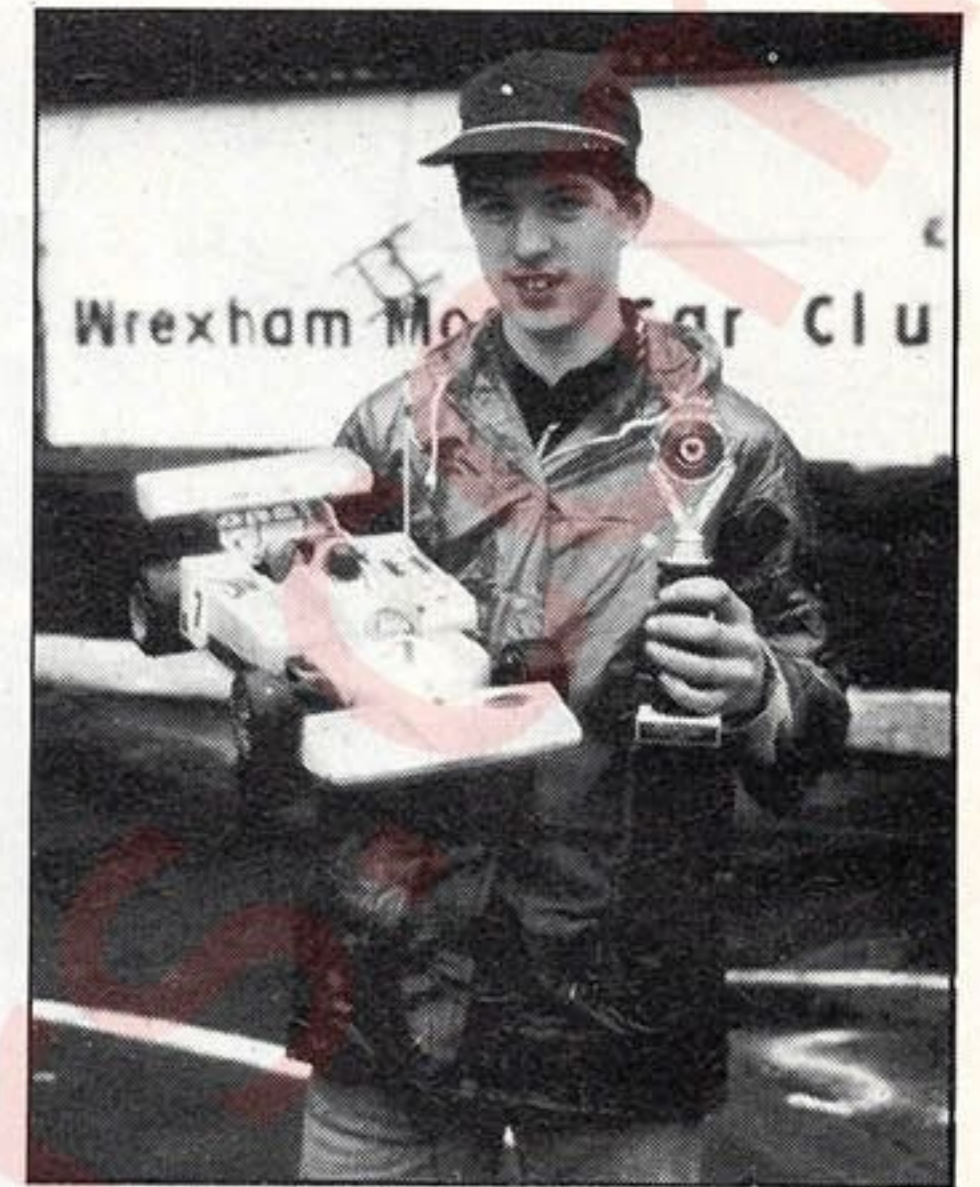

Steve Fletcher, Formula winner at Wrexham.

and Dave Dixon battling for most of the remainder of the race, in fact it was only these two who actually finished the thirty minutes, Steve Fletcher coming out the clear winner with his Nova Rossi powered Serpent ahead of Dave Dixon's S.G. and third place John Pryce. F.T.D. man Shaun Jackson finished fourth. Still, it may be Steve Fletcher's one and only open victory, but there are a lot of people who have never achieved this, and he was certainly enjoying the moment.

Sunday, and here there was a complete change in the weather, oh no! Sorry that was Monday, Sunday was no different to Saturday. Gary Culver made an appearance and showed us the size of tyres that you had to have to start a heat. The picture shown here, has a front and rear as used in America, between a normal sized pair. Note also the new Serpent lightweight hubs. Gary tells the story that he was given a new Nova Rossi motor in America that was the fastest thing he had ever had by far — and none of Gary's motors have ever been slow now have they, only to find that in the race heats he was lapped, not once, but twice! I think this really does sum up the World Champs of late. With no weight limit and extremely high traction, it is all about lots and lots of horses pulling less and less weight which all adds up to ... well draw your own conclusions, perhaps I'm getting cynical, or am I?

Anyway, back to reality at Wrexham in the rain. Gary did try to run his lightweight car in the damp only to find that it was five whole laps off F.T.D. yes five laps.

This time it was Chris White who took the

The sports finalists at Wet Wrexham.



The PB trio: Mike Jackson (left), Chris White (centre) and Shaun Jackson.

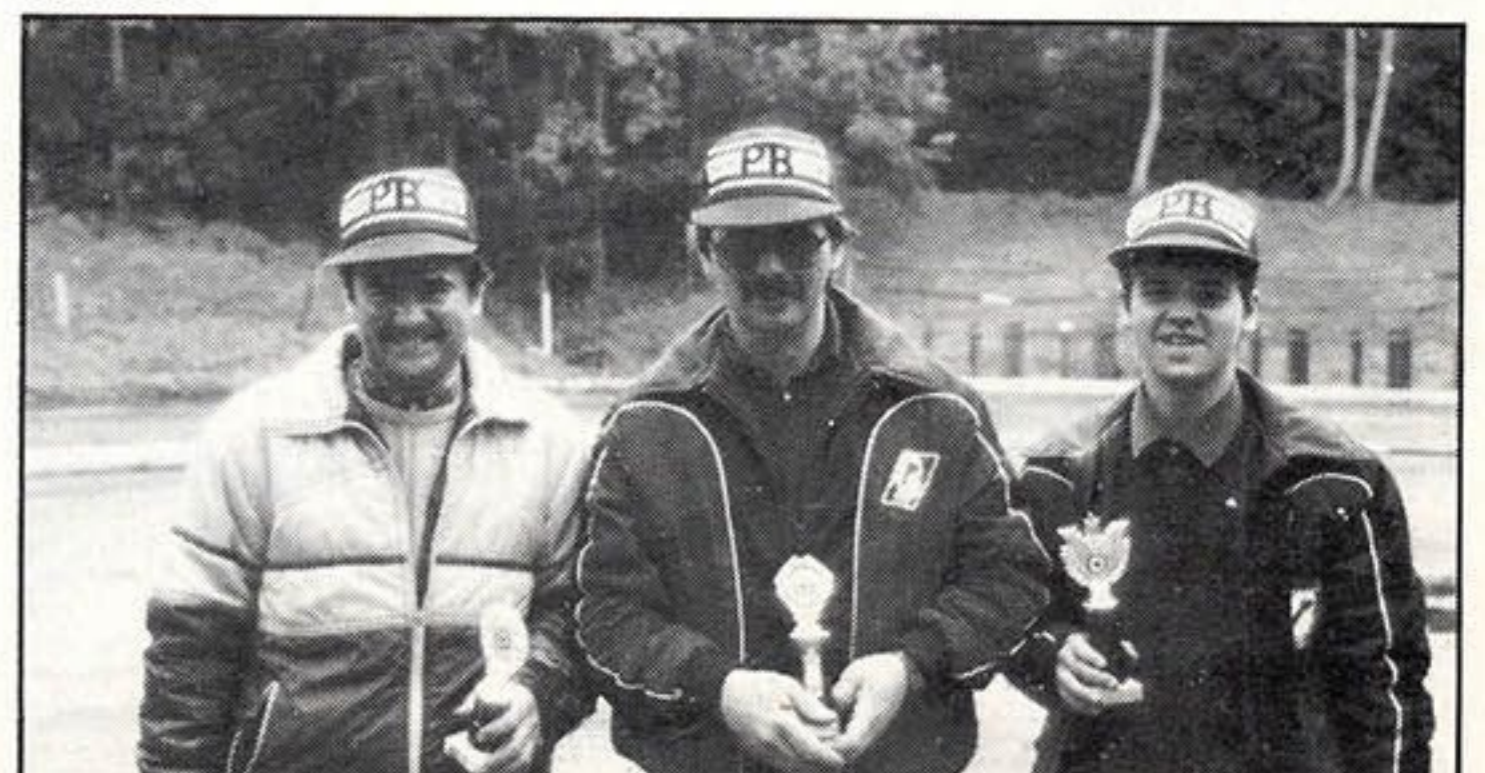

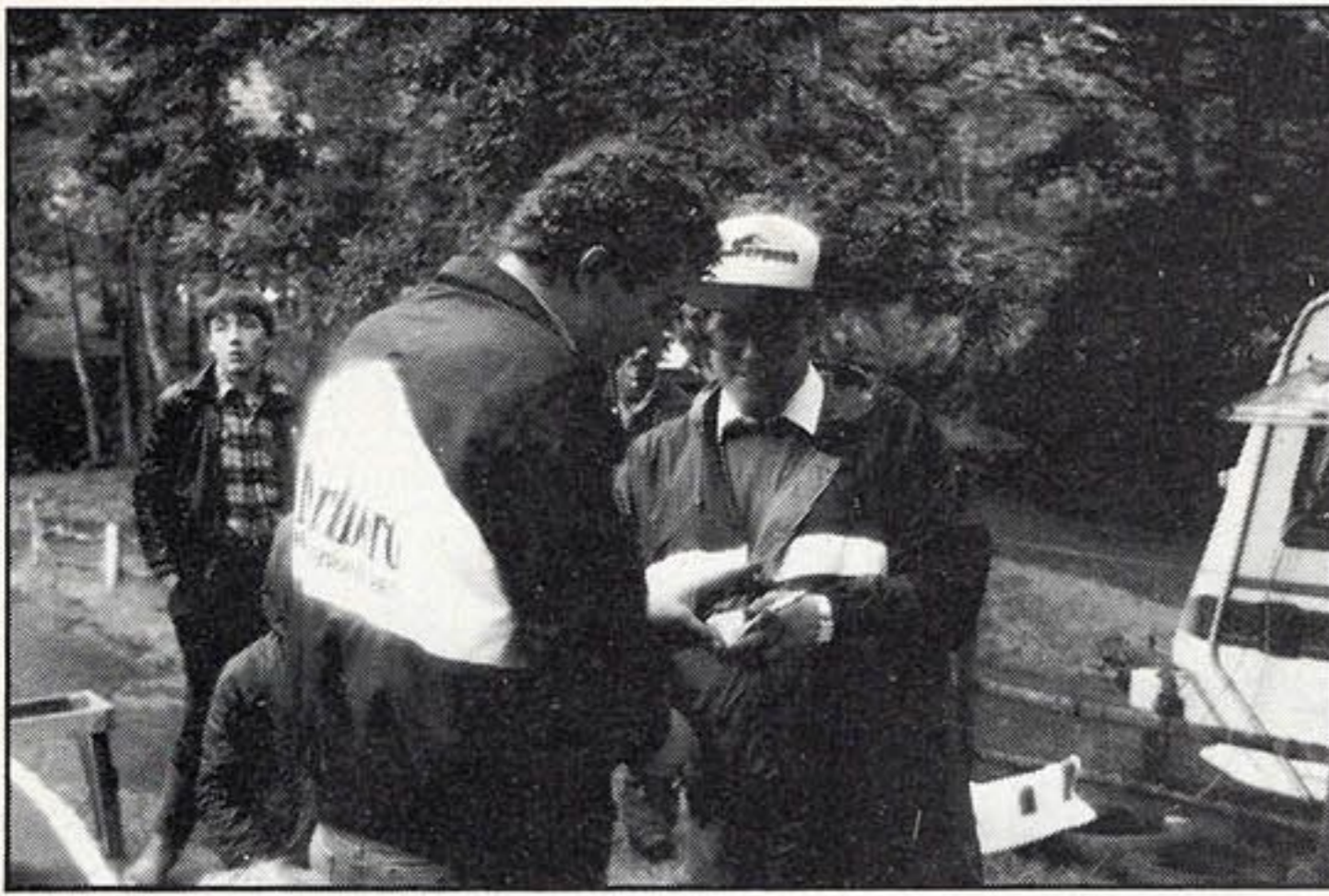

Ian Anderson receives his first ever open trophy from Jeff Vale.



Wet through, isn't it!

F.T.D. with 20 laps in five minutes seven seconds and he was over a lap ahead of brother Steve in second spot. Steve Fletcher qualified for the Open yet again in fourth spot and Ian Anderson from the London club made his first open after qualifying seventh.

The final itself was a bit disappointing as Chris White pulled out very early leaving it on a plate to brother Steve who then proceeded to drive smoothly enough to keep ahead of a hard charging Colin Straus, who eventually had to settle for second spot ahead of the impressive Steve Fletcher in third and Frank Chung in fourth. Local drivers Lee Hughes and Harry Barnes took fifth and sixth and Ian Anderson finished seventh.

Steve Fletcher must surely be pleased with his weekends work and the P.B. trio of Chris White, Mike and Shaun Jackson also did their fair share of cleaning up with the trophies.

This months — What's On.

September 6 — Mendip Sports Club round

September 6 — Southampton Sports Club round

September 13 — East Midlands Round 10 — Lilford.

September 19/20 — BRCA Round 11 — Halifax

September 20 — Mendip Formula Club round

September 20 — Southampton Saloon Club round

September 20 — London Club round 7.

September 26/27 BRCA Round 12 — Mendip.

October 4 — East Midlands Round 11 — Tibshelf.

October 4 — Mendip Saloon Club round.

October 4 — Southampton Sports Club round

October 4 — London Club round 8.

October 11 — Mendip four hour team race.

I've included the team race because it really is a good fun event, even if the Wombwell club do seem to win it lately. If you are thinking of entering a team you really could with six people. Four to drive, one to marshal and one to organise and do the fuel stops. Then make early contact with the Mendip club because places are always short and the race is limited to ten

teams. Racing usually commences at 12 noon on the Sunday with practice available from Saturday onwards.

Two weeks later saw the next round at Aldershot and a much depleted entry it was, what with people away at the Dutch Grand Prix and many others either en route to, or preparing for the Formula European Championships on the following weekend in Denmark. This does pose the question on leaving the weekend before a championship free? Anyway with most of the top names missing the event was not fast but all enjoyed it nevertheless. Colin Straus took the F.T.D. in formula from a hard chasing James Haydon to lead an all Serpent final. Unfortunately no finals results yet to hand.

Sunday was sports day and this time James Haydon took F.T.D. with 20 laps in 5 mins 306 secs. from Nigel Sayles, in between trips to and from Scandinavia and Mike Hooper third. Murray Collins took eighth qualifying spot to give him his first open final.

James Haydon had a four lap victory in the final over Steve Hart from Southampton and Nigel Sayles third. Chris



A village of umbrellas at Wrexham.

Start of the final.

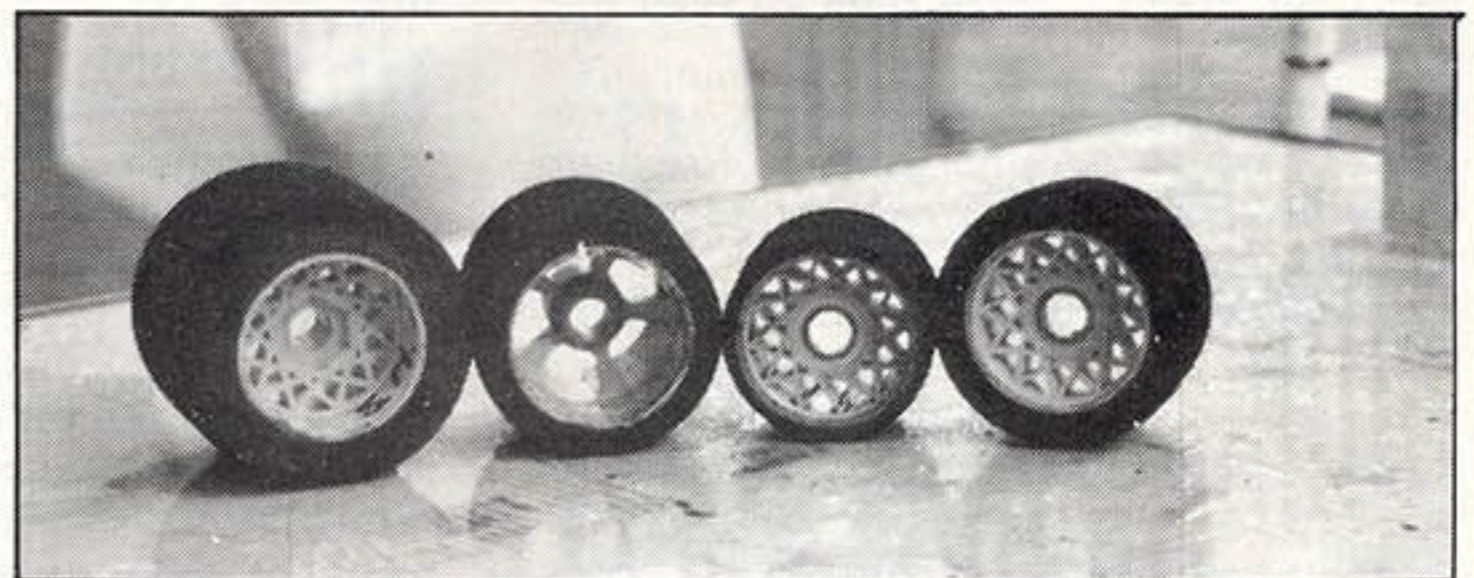
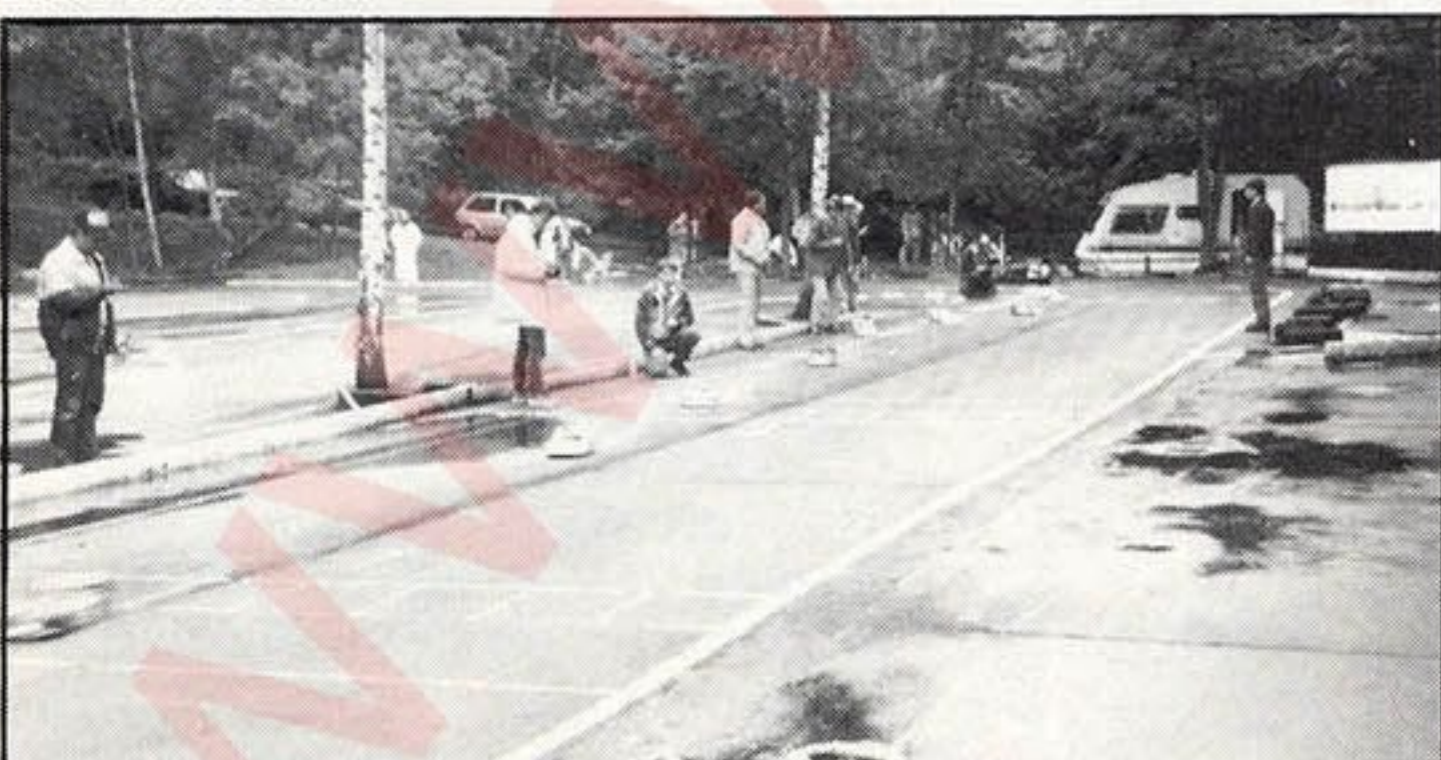

Gary Culvers' tyres as used in the USA.

The hairpin caused many, many problems.

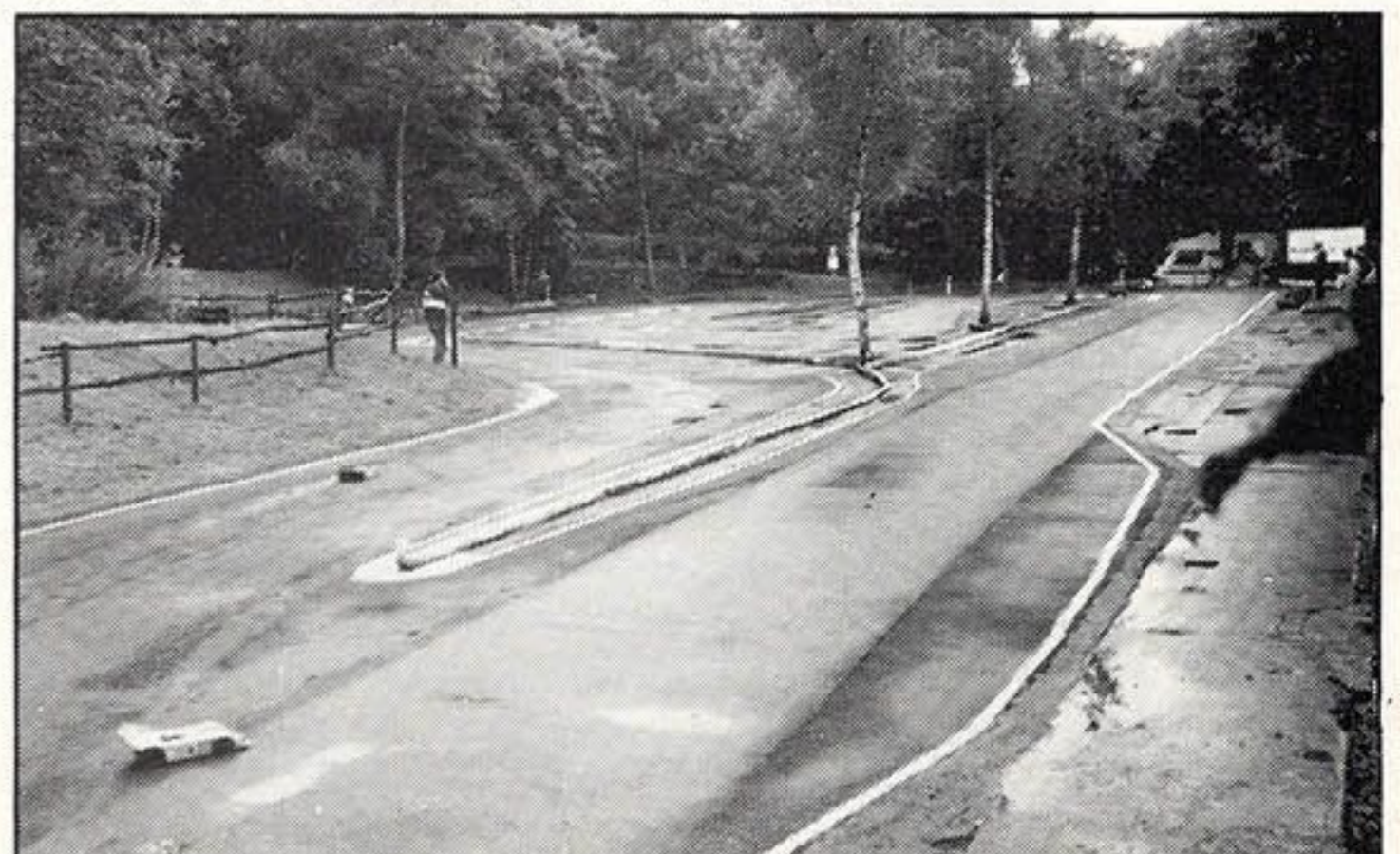

White placed fourth, Roly Leonard fifth, Mike Jackson sixth, Mike Hooper seventh and Murray Collins eighth — but at least he was there.

Finally this month, here are the present lap records for Halifax and Mendip:-

Halifax, Formula: Phil Hague 1985, Serpent 16 laps 5 mins. 5 secs.

Sports: Gary Culver 1986, Serpent 17 laps 5 mins. 0 secs.

Mendip, Formula: Gary Culver 1987, Serpent 20 laps 5 mins. 1 sec.

Sports: Bob Errington 1987, SG Space 21 laps 5 mins. 4 secs.

Next issue — full report on the European Champs.

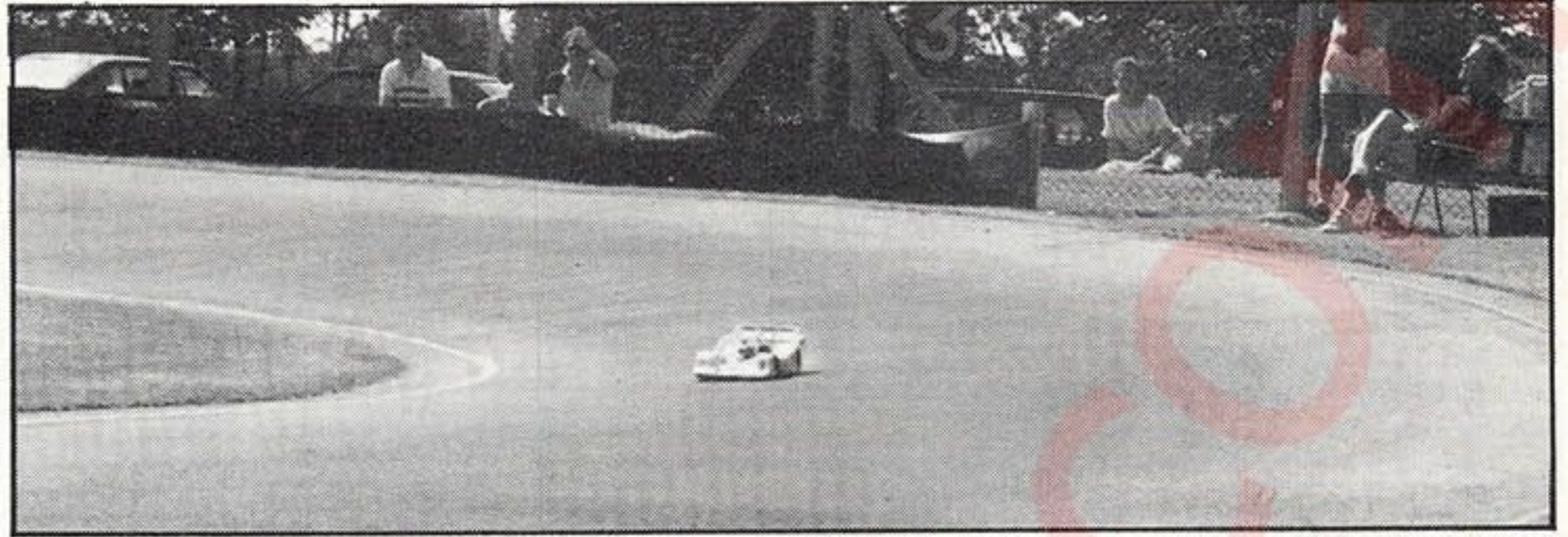

Sunny old Tibshelf. Ah dry, warm, comfortable old Tibshelf.

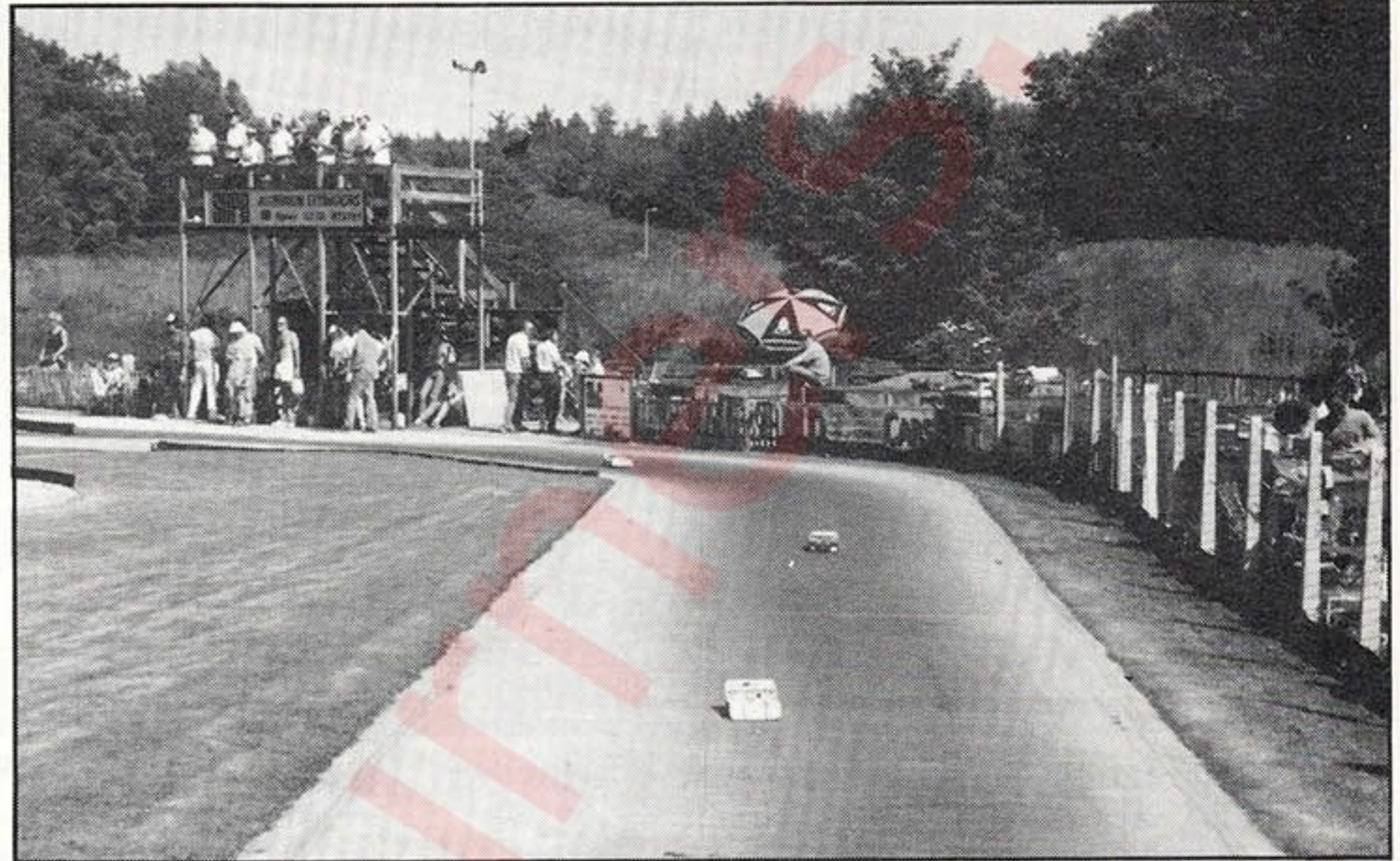

*Radio Race Car  
Sets the pace  
again and again*

# DIARY DATES

## Motor Service at the Tamiya Championships

For anyone wanting to see the Motor Service in action then make sure you pay a visit to the 1987 Tamiya Championship Finals in October.

The finals are being held at the Three Counties Showground in Malvern, Worcestershire on the weekend of October 3/4.

Helger Racing will be present with their complete service to not only help out the competitors but also to service motors brought in by spectators. On the day the Helger Racing technicians will offer you a free inspection and Dynamometer test to tell you exactly what your motor needs from the list of services.

So make it a date to see the best Tamiya drivers in the country racing and get your motors serviced at the same time.

See you there!

## Get the Best from Your Motor

Following on from the success of their Motor Service at the Parma sponsored World Championships, Helger Racing are now able to offer you a fully professional rebuilding service through their extensive dealer network in the UK.

The full range of services are as follows (but note not all are possible on standard motors).

- Magnet Zapp (Std/Mod) = £1.50
- Strip/clean/reassemble/Zapp = £5.50
- Commutator True (Mod) = £1.50
- New brushes (Yokomo/Kyosho) = £3.00
- New brushes (Tamiya) = £5.00
- New springs = £1.70
- New armature (incl. reassembly) = £18.00
- New bearings (Mod) = £2.50 each

All the above represents excellent value for money by allowing you to get the maximum use from your motors. The ser-

vice is available for any make of motor — standard, modified and 360 size and not just PARMA motors.

## W.L.R.C.

The West London Racing Centre will be holding its first race meeting on September 20. The W.L.R.C. is a purpose built centre for radio controlled races and will hold regular meetings throughout the year on and off road.

W.L.R.C. is situated in Gulliver Close, Northolt, south east corner of "the target" junction of the A40 and A312.

Further details from Adrian Jacob 0895 36745.

## Kidderminster Annual Championship

Kidderminster model car club are holding the second 1/10 annual championship on 4 October at the CMC Leisure Centre, Stourport Road, Kidderminster.

Open practice begins at 8.30 and racing starts at 10.00 standard motors only.

For further details write to Vic Dawson, 60 Aster Avenue, Franche, Kidderminster, Worcs, DY11 5DT. Tel: 0562 754155.

## Stockton Buggy Club

Stockton buggy club are holding a 1/10 open competition on Sunday September 20 to B.R.C.A. standard rules. An indoor meeting will be held on Sunday November 8 at the Stokesley Leisure Centre, also to B.R.C.A. standard rules.

Full details of the above are available from P. Watt, 97 Cedarwood Glade, Stainton, Middlesborough, Cleveland TS8 9DL.

# Windsor Model Shop

MAIL ORDER SPECIALISTS (0753) 856321

45 Albany Road, Windsor (off St. Leonard's Road)

## CARS 1/10th ELECTRIC

TAMIYA	
Grasshopper	£49.50
Hornet	£55.00
Falcon	£69.00
Boomerang	£99.00
Big Wig	£160.00
Porsche 959 4 x 4	£149.00
Optima 4 x 4	£118.00
Mini Mustang 4WD S/S	P.O.A.
Mini Mustang 4WD 2 Speed	P.O.A.
Tamtech Porsche/Lancia complete	£155.00
Mini Stock 1/2	£39.95
Blackfoot	£87.00
Turbo Optima	£199.00
Rocky 4WD	£99.00
NEW Monster Beetle	£93.00
NEW Salute 4WD	£174.00
NEW Striker	£64.00
Meteor Competition	£57.00
Meteor Standard	£59.95
Schumacher Cat 4WD	£175.00

## NICADS

Pencells	£1.10
Sub C Saft	£2.20
Saft 7.2 Tamiya	£18.25
Saft 7.2 Flat	£17.50
Sanyo 7.2 Flat Selected	£19.50
Sanyo Reds SCR	£19.50
Receiver Packs Flat only	£4.40
Sanyo Receiver Packs, Dumpy 450mAh	
4 cell packs	£7.95
5 cell packs	£8.95

## ENGINES

Irvine 20 ABC	£48.50
OPS Rear Exhaust	£122.10
OPS Side Exhaust PRO	£125.50
CMB 86	£78.95
Rossi .21	£99.50
Mondial Rear Exhaust	£99.50
New Cippola Rear Exhaust	£70.00
Cippola Side Exhaust	£59.95
OPS Gold Plugs (10)	£29.95
McGregor Glo-Clips	£5.25
MacGregor Plug Spanner	£2.75

## RADIO

Futaba Attack	£56.00
Futaba 2LGX	£119.50
Futaba Magnum Junior	£89.95
JR Beat 2	£55.95
JR Beat 2 Prof	£89.95
Alpina Steering Wheel	99.95

## CARS 1/8th I.C.

Mardave Marauder Off Road	£49.50
Mardave Stockcar MK3	£49.50
S.G. Tiger 2WD	£142.50
Siccom Magnum Propulsion 4x2	£231.59
Siccom Magnum 4x4 2-diff	£299.00
Siccom Magnum 4x4 3-diff	£339.00

## ELECTRIC MOTORS

Kyosho Le Mans 480T	£25.00
Kyosho Le Mans 480S	£25.00
Kyosho Le Mans 240S	£25.00
Mabuchi Endurance	£24.00
Mabuchi Sprint	£24.00
Mabuchi 540S	£5.95
Mabuchi 380S	£4.25
Demon 25 turn	£12.00
Demon 27 turn	£11.95
Lazer Buggys/Controller	£42.00
Magnum 360L	£17.20
Ripmax Spirit 600	£11.95
Parma Porsche 28T	£11.95
Parma Pink 28T ADV	£11.95
Raceprep Scorcher	£11.95
Yoko O5 Stock	£11.95
Parma Yokomo Armatures	£17.64

## CHARGERS

MFA 5-6-7-8 Cell fast Charger	£16.95
MFA Field Charger (Pencells)	£15.95
MFA Mains Transformer	£15.95
Jester 5.6 cell Fast Charger	£15.95
Jester Pencell Charger up to 16	£10.65
MFA Fast Mains Charger	£32.50
Jester Hercules Peak	£24.95
Schumacher Peak	£29.95

## TYRES 1/10th OFF ROAD

Tamiya Frog	pair £6.99
MRC	pair £7.40
Hotshot Spike — Front	pair £4.20
Rear	pair £4.70

Parma, PB, Dynamite Tyres in Stock

## BODIES

Rough Rider 1/10th Lexan	£7.95
Beetle 1/10th Lexan	£9.95
Grasshopper 1/10th Lexan	£9.95
Corvette 1/8th Lexan	£9.95
1/10 Parma Stinger	£9.95
1/10 Parma Subaru	£9.95
1/10 Freuer RS200	£10.50
1/8 Parma RS200	£9.95
Frog Jumper	£9.95
Desert Dog (Optima)	£9.95
Sly One (Fox)	£9.95
Mono-Chenowth	£9.95
Yokomo Chenowth	£9.95
Metro 6R4	£10.95
1/10 Lancia Rally	£9.95
1/10 Eagle (like Ninja)	£9.95
1/2 Beetle (Big Bear etc)	£9.95

## SERVOS

Futaba 134 (Brick)	£45.00
Futaba S128 Std	£17.00
Futaba 131S 5kg Servo	£48.00
JR 4001 4.2kg Servo	£38.95
JR 505 Std Servo	£16.95

## SPECIALS

7.2v Connectors Battery End	66p pair
7.2v Connectors Charge End	66p pair
6v Connectors Battery End	pair 66p
6v Connectors Charge End	pair 66p
Flexan Spray	£2.45
Humbrol Lexan Paint Tin	£1.65
Tamiya Lexan Paint	£1.85
Frog Diff	£11.50
Frog Shocks	pair £9.99
H/Duty Kydex Bumper R/Rider	£2.95
H/Duty Kydex Bumper Frog	£3.25
H/Duty Kydex Bumper Scorpion	£3.45
H/Duty Kydex Bumper Boomerang	£3.95
Also Lexan Bumper to fit most cars	
Ball Races Tamiya	£1.75
Tamiya Small Bearing	£1.95
Ball Races Scorpion	£1.95
Optima Ballraces — large	£2.25
small	£1.95
Heat Sink 540 Motors	£4.95
Heat Sink 380 Motors	£4.50
Heat Sink Hotshot	£2.98
Pinion Gear Frog 10T-20T Ally	£1.45
Pinion Gear Frog 10T-20T Steel	£1.95
Frog Lightweight Drive Shafts	pair £2.99
Parma Servo Savers, Off Road	£4.25
Delta Aerials	£1.99
Steel UJ Tamiya/IC Cars	£11.50
Kimrough Servo Saver Large	£4.30
Kimrough Servo Saver Small	£2.58
Parma Motor Cover	£1.45
Parma 4mm Wing nuts	£1.65
TMS rear guard Optima	£4.75
SRM Roller Bearings	£21.95
Boomerang Steel Ball Pins (4)	£3.25
Schumacher ni-cad Clamps	pair £1.50
Parma Front Brace (Hotshot)	£2.45
Tamiya Boomerang Shocks	
long/short	pair £11.99
MRM Buggy Caddy	£19.95

# THE SICCOM MAGNUM 4 x 4

## NEWS FLASH

Magnum Wins Again

1st, 2nd & 3rd

## BRITISH GRAND PRIX

MAGNUM 4x4 2-diff.	£299.00
MAGNUM 4x4 3-diff.	£339.00
NEW MAGNUM 4x2 propulsion	£231.59

Looks exactly like Magnum 4x4 and can be converted to full 4x4 3 diff. spec. for only £107.41 making the total conversion cost no more than the price of a new Magnum 4x4 3 diff. kit. Why waste your money on inferior models when you can buy and race the very best two wheel drive car now and upgrade to 4 wheel drive when funds permit!

TRADE ENQUIRIES WELCOME



Open Mon-Sat 9 am-6pm. Half day Wednesday



1/12 BODY SHELLS LIGHTWEIGHT/STANDARD SERPENT SPARES 1/8 BODY SHELLS MODEL RAILWAY 4MM SCALE

## Sarik-Vacform

SIMPLEX IND. EST., HIGH STREET, OLDLAND, BRISTOL BS15 6TA, ENGLAND  
TEL. 0272 326537/693235

As one of the largest manufacturers of bodyshells in the UK, you can be sure of competitive bodies at competitive prices — shells that the top drivers use. Most of the 1986 1/8 National Meetings were won using shells manufactured by us.

Latest design now available — Can Am Spyder SP/GT. This one has been developed with the help of top drivers like Gary Culver and Rody Roem. Should not need to use rear wing so you are quicker through the air — and quicker to the finish line!

Send SAE for lists/brochure or ring.

1/10 and 1/12 as always — in stock.

DRIVE A WINNER USE SARIK

STANDARD SERPENT SPARES 1/8 BODY SHELLS MODEL RAILWAY 4MM SCALE

## NEW BUGGY TRANSPORTER

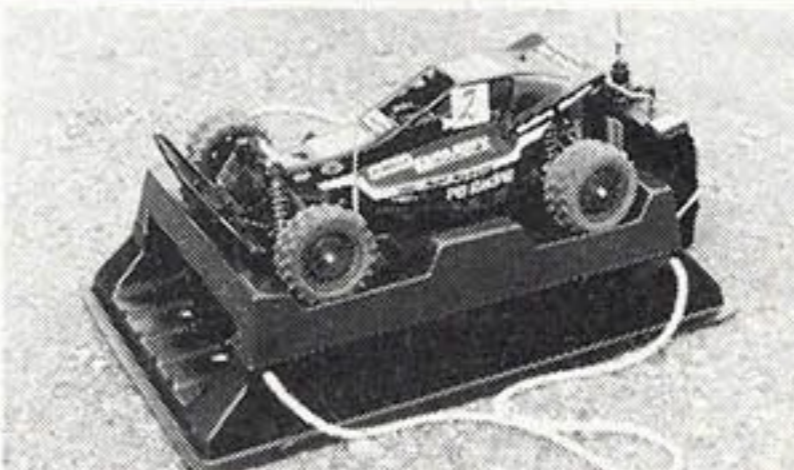

### FEATURES

- Will carry all 1/10 BRCA Legal Buggies
- Large 15 x 8 positive lock drawer
- Transmitter carrier built on end
- Top has built in tray for nuts & bolts etc.
- Moulded in lightweight hi-impact styrene
- Available in Bright Red, Yellow, Blue and White

£18.50 + £1.25 post & packing

Carry your Buggy, Transmitter & Tools in great style

FROM: M.R.M. PLASTICS, BEETONS YARD, SHOTTISHAM, WOODBRIDGE, SUFFOLK IP12 3KT

TEL: 0394 411968 Factory No. TEL: 0473 626449 After Hours No.

BARCLAYCARD

ACCESS





# PEELERS

— Custom Decals — ©

Ten exciting new designs in an A4 size now available, with a further six designs following shortly

*Look for the Window Stickers for your Local Stockist*



No 6, 26/28 Market Place, Blandford, Dorset, DT11 7EB.

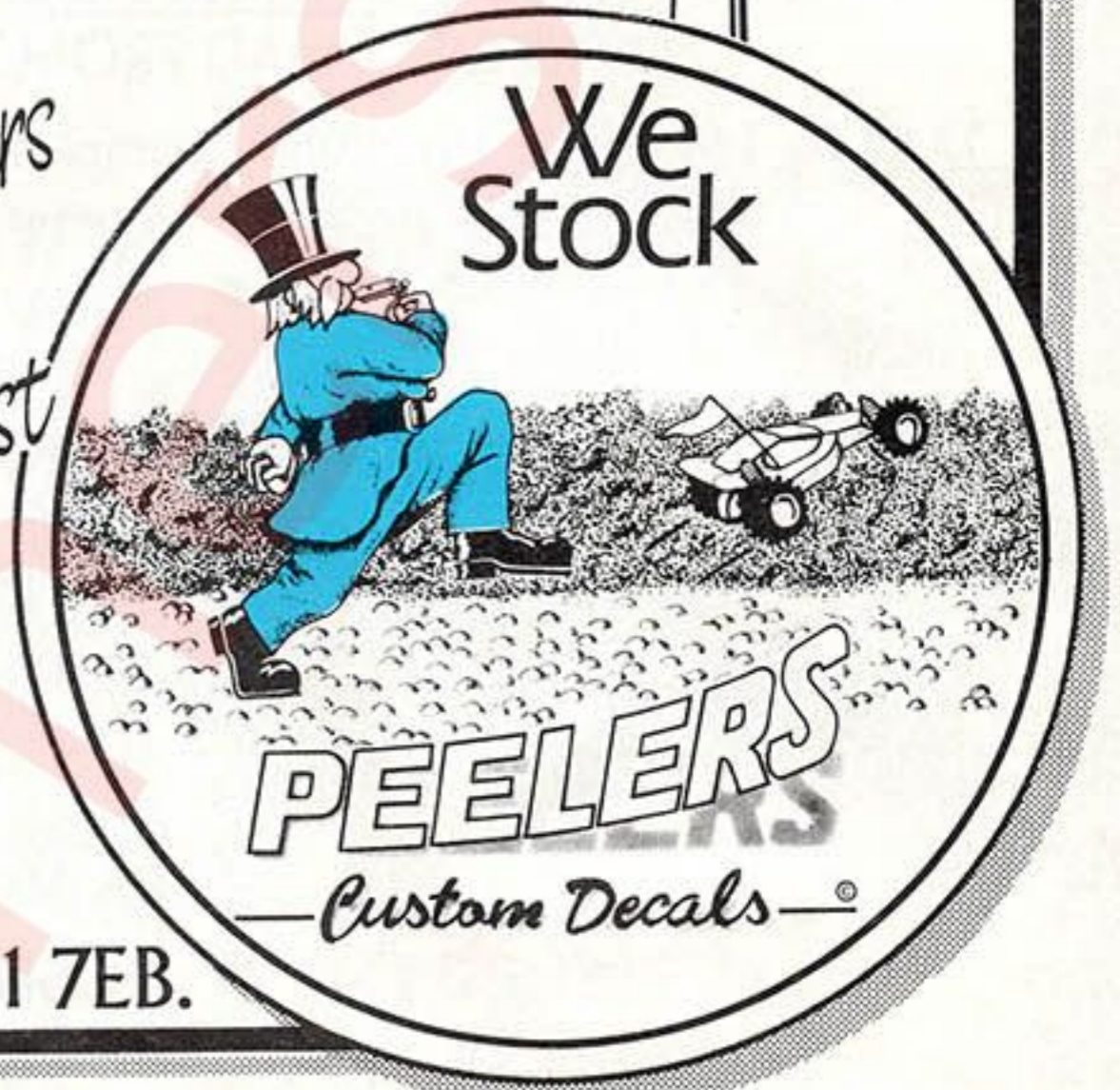

## FREE TO ENTER COMPETITION

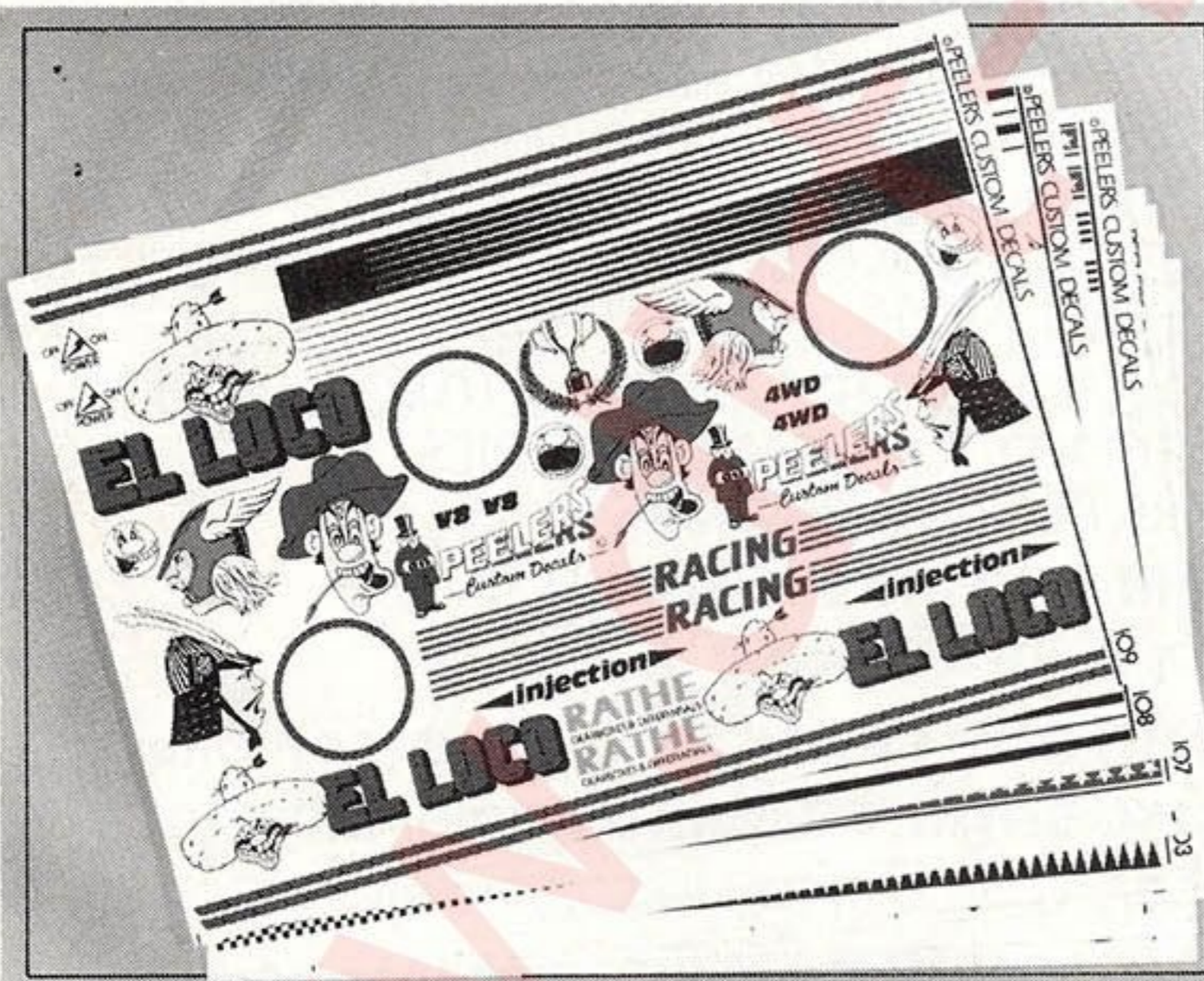

Thirty sheets of Peeler super decals to be won in the Radio Race Car design and decorate competition.

All you have to do to win is draw, paint or illustrate your dream bodyshell, complete with custom trim, i.e. decals, concours paint job etc. and you could be one of three lucky winners each receiving ten sheets of Peeler stickers. Each sheet is different portraying a separate style and the quality of each is first class.

Closing date for entries will be Friday, October 23rd 1987 and winners will be notified by post.

This competition is not open to members of staff of Traplet Publications or their relatives. The judges decision is final and no correspondence will be entered into.

Send your entries with this coupon to Traplet Publications Limited, Masefield House, Wells Road, Malvern, Worcestershire, WR14 4PA, England.

Name .....

Address .....

Post Code .....

# TED LONGSHAW

## MODEL CARS

### THE R/C CAR RACING SUPPLIERS

IF YOU RACE MODEL CARS YOU MUST HAVE A COPY OF OUR **NEW** CATALOGUE.

**FREE! JUST SEND S.A.E.**

WE CAN SUPPLY **SAME DAY DESPATCH**. KITS & SPARES FOR 1:12, 1:10, & 1:8 CIRCUIT & OFF-ROAD FROM ALL THE FOLLOWING MANUFACTURERS:-

D.W.A. 1/4 Scale absolutely complete, only needs radio gear, off road or circuit **£795** inc. V.A.T.

#### P.B. RACING

**NEW MUSTANG**, 1:8 SCALE 3 VERSIONS. SEND FOR DETAIL  
**NEW** U.J. DRIVE SHAFTS FOR MINI MUSTANG SOLID TYPE  
 £14.57 PR WITH ONE WAY BEARING £27.97  
**NEW** 2-SPEED PINIONS WITH 4T SPACING  
**NEW** ELECTRONIC SPEED CONTROL WITH REVERSE £59.80  
 (INCLUDES 6 FETs)

#### RADIOS (CAR)

DRY WITH 505 SERVOS £129.95, NICAD £169.50. WITH NEW  
 4031 DOUBLE BALL RACED SERVOS & NICADS &  
 CHARGER £228.50. PLUS ALL **FUTABA** SERVOS & CAR  
 RADIOS. SEND FOR LIST

#### ASSOCIATED

**RC500 4WD**, **RC250** CLUBMAN, PLUS ALL SPARES ETC.  
**RC12L**, **R.C.10**, PLUS SPARES, SHOCKERS ETC. LIST.

#### DEMON

ALL DEMON PRODUCTS, MOTORS ETC. ARE EX-STOCK

#### "JAP"

**30°, 35°, 40°** FRONT TYRES HUNDREDS **IN STOCK**

#### S.R.M.

ALL S.R.M. MODIFIED PARTS FOR 1:10 IN STOCK

#### M.G.

PINIONS, RED DOT, BROWN DOT, ETC. MOTORS IN STOCK

#### INTRONICS

HEAT SENSOR CHARGER INC. D.V.C. SPEED CONTROLS

#### DELTA

ANTENNA, FUEL BOTTLES, ETC.

#### SCHUMACHER

**CAT** KITS, INC. **NEW L.W.B.** SPARES, TYRES ETC.  
 MOTORS, NICADS. XL CONVERSION KITS

#### SANYO

MAIN STOCKISTS ALL TYPES NICADS

#### BOLINK

SPEED CONTROLS, 1:10 ROAD CARS ETC. 1:10 ROAD BODIES

#### HOBBYNOX

FULL RANGE OF COLOURS FOR LEXAN BODIES

#### KIMBOROUGH

GEARS, S/SAVERS, BEARING BRACKETS

#### DYNAMITE

**NEW NEWSOFT 1:10 TYRES** PLUS FULL RANGE  
 EXISTING TYRES, MOTOR END COVERS ETC.

We also have **Electronic Speed Controls**, **Tyres** from all major manufacturers, **Air Filters**, Stock Car Tyres, **3.5cc Engines** from all major manufacturers. **Chargers** from M.F.A., Schumacher, C.S., Digital, Intronics, etc. etc.

Starter Boxes, Starter Motors & Wheels. **NEW Body for M/Mustang**

**Mardave** Kits, Spares, Tyres, **Mini Stocks NEW**

TRADE SUPPLIED WITH MOST ITEMS (GENUINE OUTLETS ONLY NEED APPLY)

**TEL ORDERS:- 0689 55313**

LETTERS:- P.O. BOX 89, ORPINGTON, KENT

# AERO NAUTICAL MODELS

39 PARKWAY, CAMDEN TOWN, LONDON, NW1-7PN



**Tel: 01-485-1818**

9.15-5.30 Tues., Wed., Thur., Fri.  
9.15-5.00 Sat. Closed all day Monday

DUE TO MOVING SOME CAT SPARES HAVE BEEN IN SHORT SUPPLY. OUR APOLOGIES FOR DELAY WHICH IS OUT OF OUR CONTROL



## CAT 'XL'

Leads the field with a pedigree that shows! BRITISH INTERNATIONAL 1st, 3rd, 4th, 5th, 6th, 7th, 8th, 9th FRENCH INTERNATIONAL 1st, 3rd, 4th, 7th, 10th AUSTRIAN INTERNATIONAL 1st, 3rd, 4th, 5th, 6th, 8th, 9th AUSTRIAN EURO CHAMPS. 1st, 2nd, 3rd, 5th, 6th, 7th, 9th

The above results show that the 'CAT' has become the premier buggy for 1987. Whether Club or International racing CAT 'XL' Kit Conversion, T 642 inc. 2 pce chassis, body & undertray, XL Belt £25.00 + £1.50 p&p

Cat 'XL' Complete Kit, less R/C, Motor, electrical parts. £175.00 + £3.50 p&p

## THE CAT

Spares, any qty. 50p p&p except body & undertray £1.50 p&p

### CAT SPARES

Qty.	86p
A188 Tension Band	5
A510 B.R. 1/8 x 1/4 NF	2
A530 B.R. 8-16-5 NF	4
A532 B.R. 8-12 F	2
A533 B.R. 8-16-5 NF SS	4
A541 One Way Clutch	2
C058 Battery Clamps	2
T006 Pivot Bkt. pr	2
T012 R Wheels	2
T013 F Wheels	2
T045 Pivot Ball	4
T052 F Hub Carrier	2
T055 F Transmission Housing	2
T058 Arm Front Suspension	2
T062 Piston Rod 16mm	2
T063 Piston Rod 32mm	2
T070 Rear Trans. House Inner	1
T071 Rear Trans. House Outer	1
T074 Chassis Lower	1
T075 Chassis Upper	1
T084 Rear Axle	1
T085 Diff. Shaft	1
T086 Front Axle	1
T102 Rod End Ball	4
T103 Bumper	1
T104 Rear Hub Carrier	2
T105 F/G Rear Susp. Bkt	1
T106 F/G Rear Shock Bkt	1
T116 F/G Track Rod	1
T123 Gear 55TH	1
T124 Gear 58TH	1
T125 Gear 60TH	1
T128 Belt Long	1
T129 Belt Short	2
T132 Front Springs	2
T133 Rear Springs	2
T508 Body Moulding Sheet	1
T509 Undertray Sheet	1
Tyres Soft	4
Tyres Hard	4
T511 Shock Set	4
T513 Screw Bag	£9.65
T514 Ball Race Set	£25.94
T516 Joints Bag	£8.28
T517 Bearing House Moulding	£1.97
T518 Bkt Moulding	£1.93
T526 Front Diff	£16.75
T612 Hub Moulding	£2.66
T613 Spr. Stops & Spacers	£1.86
T614 Shock Seals	£7.69
T616 Wishbone Set 4	£2.50
T617 Pulley Mouldings 50-51T	£2.35
T618 Pulley Mouldings 21T & Cage	£1.86
T620 Screw Bag A	£2.14
T621 Screw Bag B	£3.75
T622 Screw Bag C	£3.79
T623 Ali Side Plates	£4.59
T624 Rear Susp. Pivots	£2.00
T625 Rear Anti Roll Bar	86p
T626 Front Anti Roll Bar	£1.31
T627 Servo Saver	£2.25
T628 Front Shocks Parts	£5.69
T629 Rear Shocks Parts	£5.99

T630 Drive Shafts	£3.04
T631 U/J Bag	£5.52
T632 Diff/Int. Repair Kit	£2.86
T633 Front Shocks Comp.	£15.94
T634 Rear Shocks Comp.	£16.39
T635 Front Diff. Repair Kit	£1.38

### CAT TYRES (Pr)

T650 CAT Rear Tyres 4x20 Spike-Soft	pr £6.80
T651 CAT Rear Tyres 4x20 Spike-Hard	pr £6.80
T652 CAT Front Tyres 3x20 Spike-Soft	pr £5.80
T653 CAT Front Tyres 3x20 Spike-Hard	pr £5.80
T654 CAT Front Tyres 2x20 Stud Soft	pr £5.80
T655 CAT Front Tyres 2x20 Stud Hard	pr £5.80

### NEW ITEMS

(Subject to availability)	
T 153 Bumper 170mm wide	£2.50
T 531 Futura Body Std Chassis	£7.97
T 532 Futura Undertray	£7.62
T 646 Rear Susp. Mod Kit	£2.99
Increases Rear Track to 250mm	
T 146 XL Chassis Lower	£5.80
T 147 XL Chassis Upper	£3.95
T 529 XL Body	£7.97
T 530 XL Undertray	£7.62
T 152 XL Belt	£3.55
A 534 Set 14 black brg seals for	
A 530	£1.50
P.C.3 Peak Charger with Ammeter	£44.50
T 145 'Anti-Squat' rear F/G Plate	£1.10
T 643 Rear Susp Geometry Mod Kit inc. all plates & F/G Plate	£4.59

### NODIS 'CAT' GEARS

Std Pitch (32) 54-56-58-60TH	ea. £5.50
Fine Pitch (64) 96TH to - 122TH	ea. £5.50
Integrator Assembly with Ball Raced Centre Pulley	ea. £29.95
Diff Pulleys only	pr £8.95
Fine Pitch Pinions 20-42TH	ea. £3.65

### LASER

Comfet Bug 1/10 Forward Mosfet Control with reverse and brakes ..... £69.95 + 75p post

Comfet 1/10 Forward only Competition with Mosfet braking .. £64.95 + 75p post

Compact 1/10 or 1/12 Forward & Reverse Relay Operated Controller ..... £44.95 + 75p post

Bug Mk1 Forward & Reverse Ultra Strong Controller especially recommended for beginners .... £44.95 + 75p post

Pulse Charger with Thermal Sensor Gets top performance out of your SC or SCR's, as used by majority of top drivers ..... £36.95 + £1.00 post

Be sure to get Genuine 'Laser' products. They're copied but never equalled.

### KYOSHO ROCKY SPARES

1 Bumper	£2.50
2 Wheels pr	£3.95
3 Diff. Gear Set	£11.95
4 Front Gearbox	£3.50
5 Plastic Parts Set	£6.50
6 Suspension Arm Set	£3.95
7 Knuckle Arms	£5.95
8 Chassis Deck	£5.95
9 Chassis Frame	£5.95
10 Hub Set	£3.95
11 Ball Link Set	£8.75
12 Rear Gearbox	£11.95
13 Gear Set	£8.95
14 Chain Carrier	£2.95
18 Metal Bearings	£8.95
19 Chain	£5.50
21 Gearbox Joints	£2.95
22 Front Wheel Shafts	£4.50
23 Rear Wheel Shafts	£4.50
25 Gearbox Shaft Set	£6.95
26 Rear Damper Stay	£2.95
27 Screw Set	£6.95
28 Servo Saver	£1.95
29 Decal Sheet	£2.50
15 Tyres	pair £9.50
16 Damper Set	£18.95

### BALL RACE SETS P&P 50p

Optima	£19.95
Rocky	£22.50
Fox	£5.60
Hotshot	£23.99
Boomerang	£28.99
Hornet	£14.30
Grasshopper	£14.30
Falcon	£17.20
Ninja	£36.00

### KYOSHO ULTIMA SPARES

1 Gear Set	£4.95
2 Metal Set	£3.50
3 Gear Box	£1.95
4 Motor Plate	£1.95
5 Gear Shaft Set	£2.45
6 Shock Stay Set	£2.45
7 Susp. Shaft Set	£2.95
8 Front Shaft	£2.95
9 Tie Rods	£1.95
10 Collar Set	£1.75
11 Upright Set	£1.95
12 Bulkhead	£3.25

## KYOSHO ULTIMA



PARALLEL WISHBONES/ARMS FRONT AND REAR, AND THE TRADITIONALLY E KYOSHO COIL-SPRING/OIL-FILLED SHOCK ASSEMBLY COMBINATION IS CONTI

13 Susp Arm Set	£3.15
14 Servo Saver	£1.95
15 Radio Plate	£1.75
16 Body Accessories	£3.25
18 Body	£9.95
19 Body Decals	£1.95
26 Spec Shockstay	£24.95
27 Spec Chassis	£17.95
28 Motor Guard	£6.25
29 Stabilizer	£7.95

### OPTIMA

Spares, any qty. 50p p&p Except body, £1.50

### SPARES LIST

25 Optima Body	£13.00
26 Driver Doll	£3.75
43 Rear Damper Set	pair £11.65
01 Gear Box	£4.95
02 Chain	£4.95
03 Wheel Set	pack of 4 £4.95
04 King Pin	pack of 4 £2.45
05 Joint	pair £2.35
06 Swing Shaft	pair £5.00
07 Rear Plate Set	£6.65
08 Front Side Plate	pair £2.10
09 Shock Stay	£2.75
10 Bushing Set	P10 £2.35
11 Suspension shaft	pair £2.75
12 Radio Plate	£4.65
13 Suspension Arm Set	pair £2.75
14 Under Guard	£2.10
15 Front Bumper	£2.10
16 Knuckle Arm	£3.90
17 Front Shaft	pair £3.50
18 Rear Shaft	pair £3.50

### OPTION HOUSE

Subject to Availability!

Opt. Motor Guard	£5.50
Opt. Side Guard	£10.25
Light Carbon Fibre Sht	£29.95
Shocks Front	£22.95
Shocks Rear	£22.95
Low profile wheel	(pr) £4.95
L/P tyres general	£8.75
L/P tyres Hi Grip	£8.75
Universal Joint Swing Shaft Opt. Rocky	£19.50

### S.R.M. RACING PRODUCTS

#### OPTIMA ACCESSORIES

Tall Shock Mounts F.	£3.95
Tall Shock Mounts R.	£5.65
Skid Plate	£5.75
Hotshot Wheel Adap. '2'	£4.75
Fox Wheel Adap. '4'	£5.95
Poly Bones	Pr. £3.95
Roller Clutch	£21.95
Nerf Wings	£6.50
Radio Plate	£8.15



### NODIS OPTIMA BELT DRIVE CONVERSION

Set 'B' inc. two Pulley Drives for existing Gear Drives, Belt plus Drill Jig for Chassis Rails ..... £24.50  
Set 'A' inc. two Pulley Drives for existing Gear Drives, wide Belt and requires no mods to chassis ..... £28.95  
Both Subject to availability

### NODIS OPTIMA GEARS

Steel Final Pinion OT41	£3.95
Layshaft and Gear	£5.40
Compound Gear 38-39-40-41-42TH	ea. £6.95
Also available in Fine Pitch (64): Compound Gears 76-78-80-82-84T	
	ea. £6.95
Pinions 20-42T	ea £3.65

# HOVER BUG 540 SERIES

**NEW**

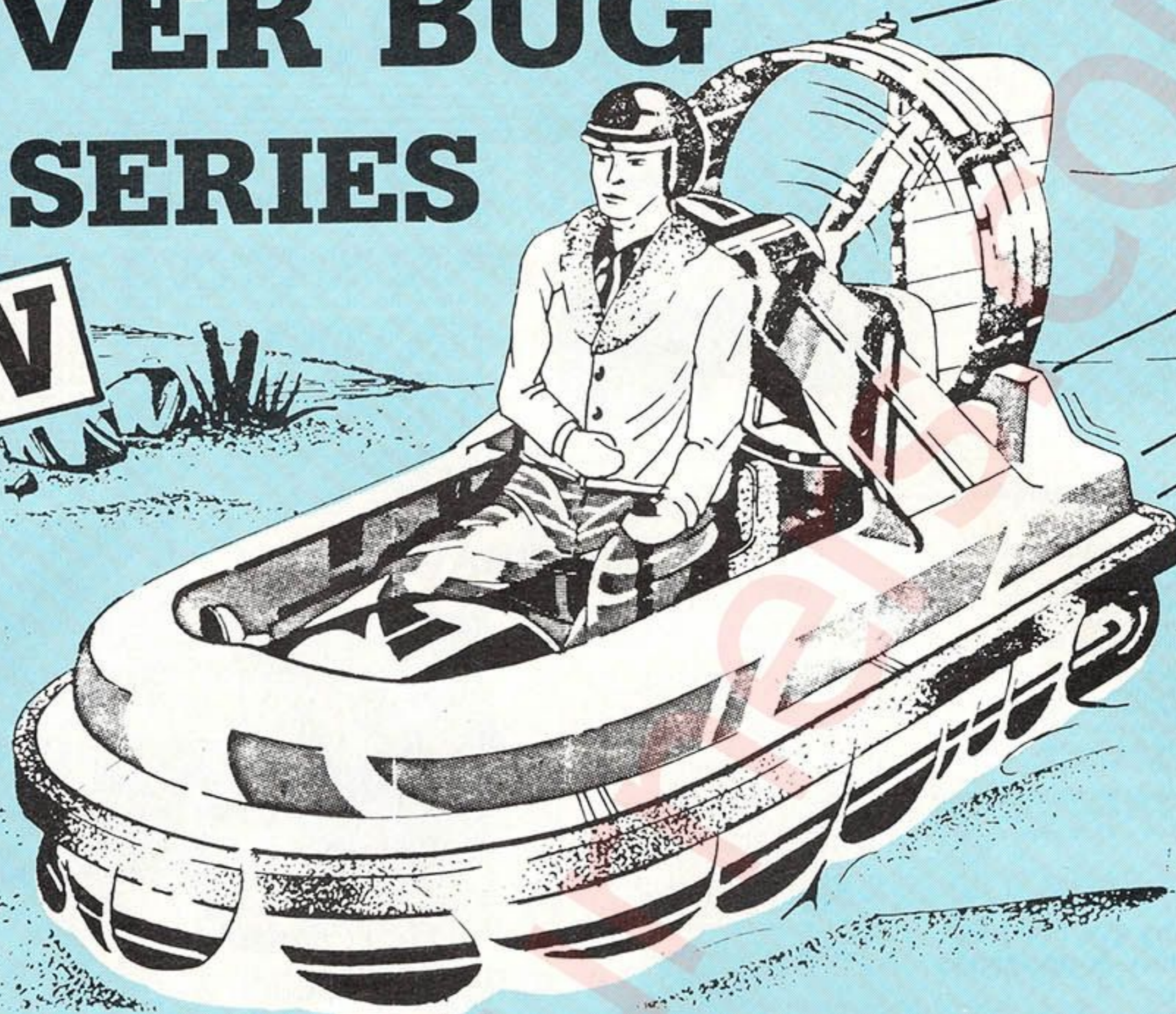

## ALL ELECTRIC HOVERCRAFT

- Two channel operation
- All Parts Ready Formed
- Easy construction
- Operates on a buggy type motor and battery pack
- 20" long, 10½" wide, 9" high
- A fun craft with a sparkling performance
- Trade enquiries welcome
- **PRICE £29.45 P&P £1.90**
- If you are finding it difficult to obtain one contact direct

**Sun Lane Engineering Co. Ltd.**

**SLEC House, 2 Stacey Close, Gravesend, Kent,  
DA12 5PD, England. Tel: Gravesend (0474) 67587**

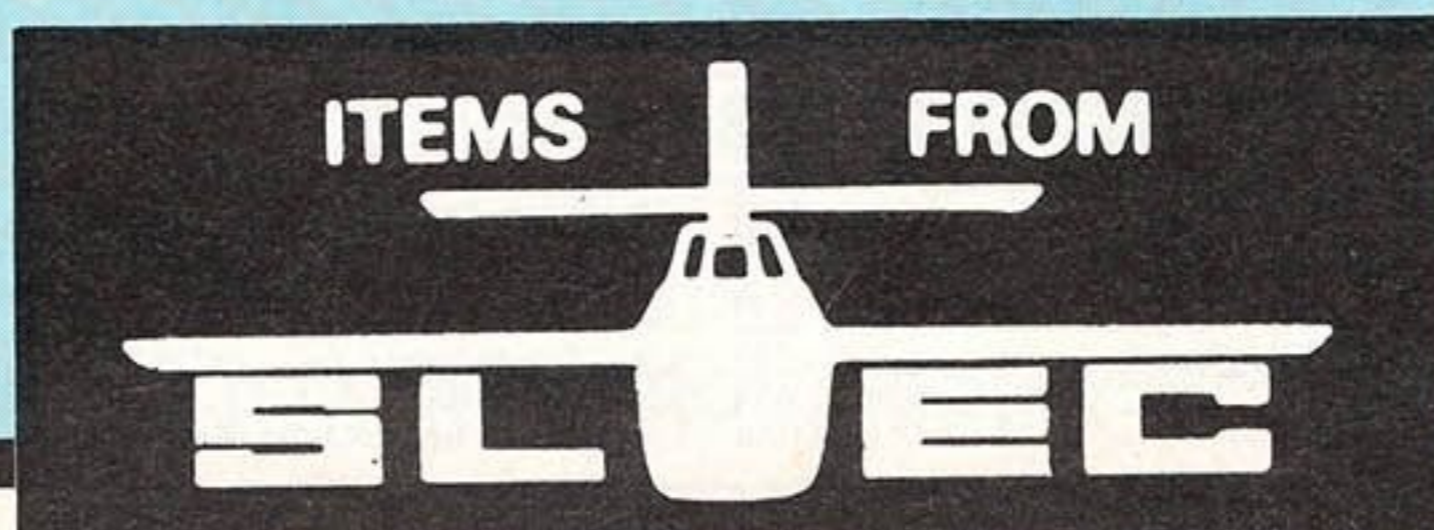

# HOWER BUG



Radio Race Car looks at the alternative way of going places using 7.2 volts and a 540 motor.

Until a short while ago, floating on air was only possible if you owned a magic carpet, that is until a young engineer discovered the flymo and elevated the whole principle into a form of transport. Or should that be the other way round? Oh well, the young engineer's name was Christopher Cockerell and for his pioneering work in the field of hovercraft, he was awarded a knighthood, he is now known as Sir Christopher Cockerell.

History lesson over, from that original one man vehicle evolved a series of hovercraft, the most well known must surely be the huge monster type that ferry people between England and France.

Hovercraft development in the modelling world has been fairly sparse over the years, one or two have been allowed to dip their toes in the lukewarm waters of the retail shelves, but it seems they ventured no further.

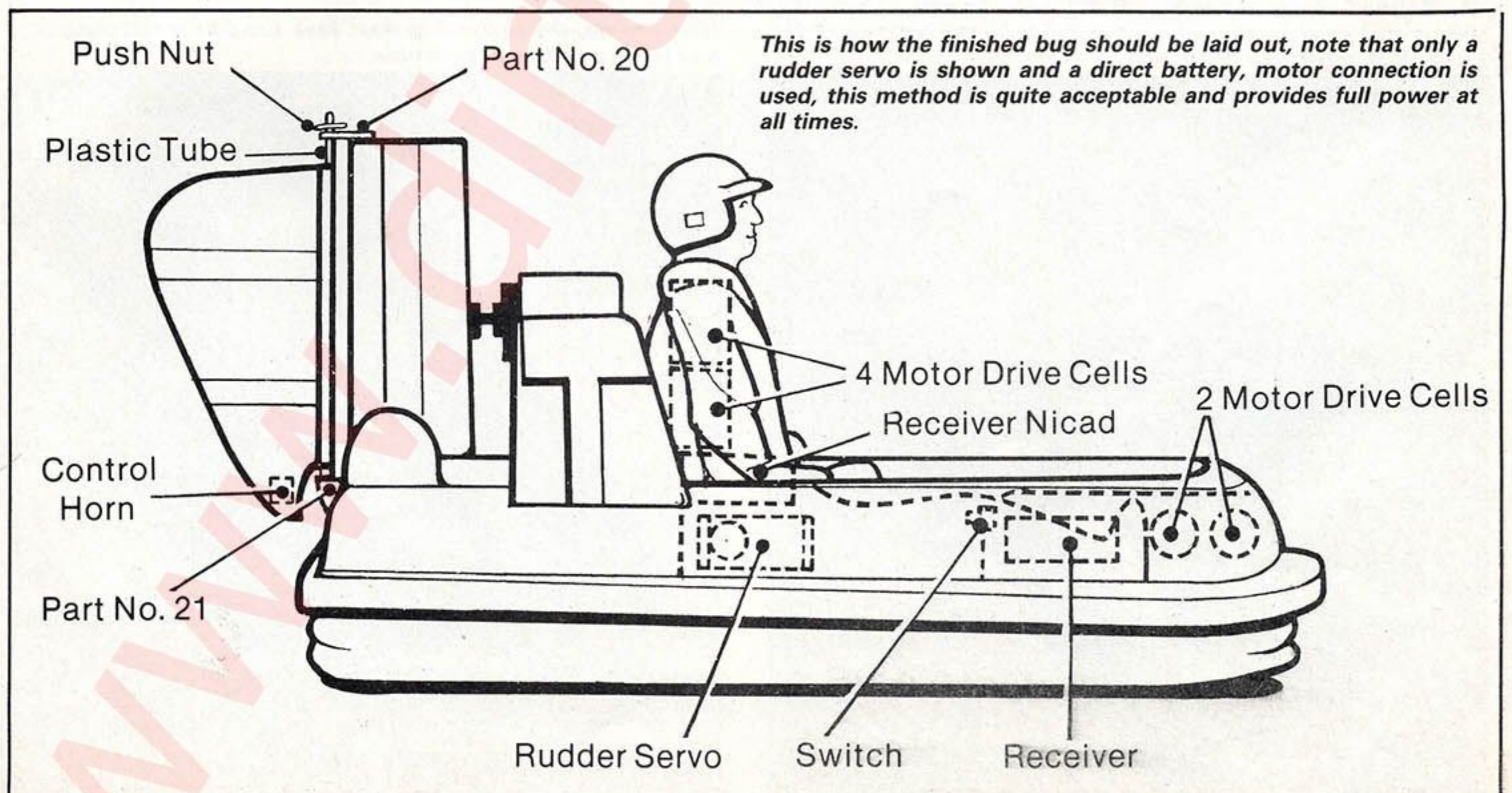
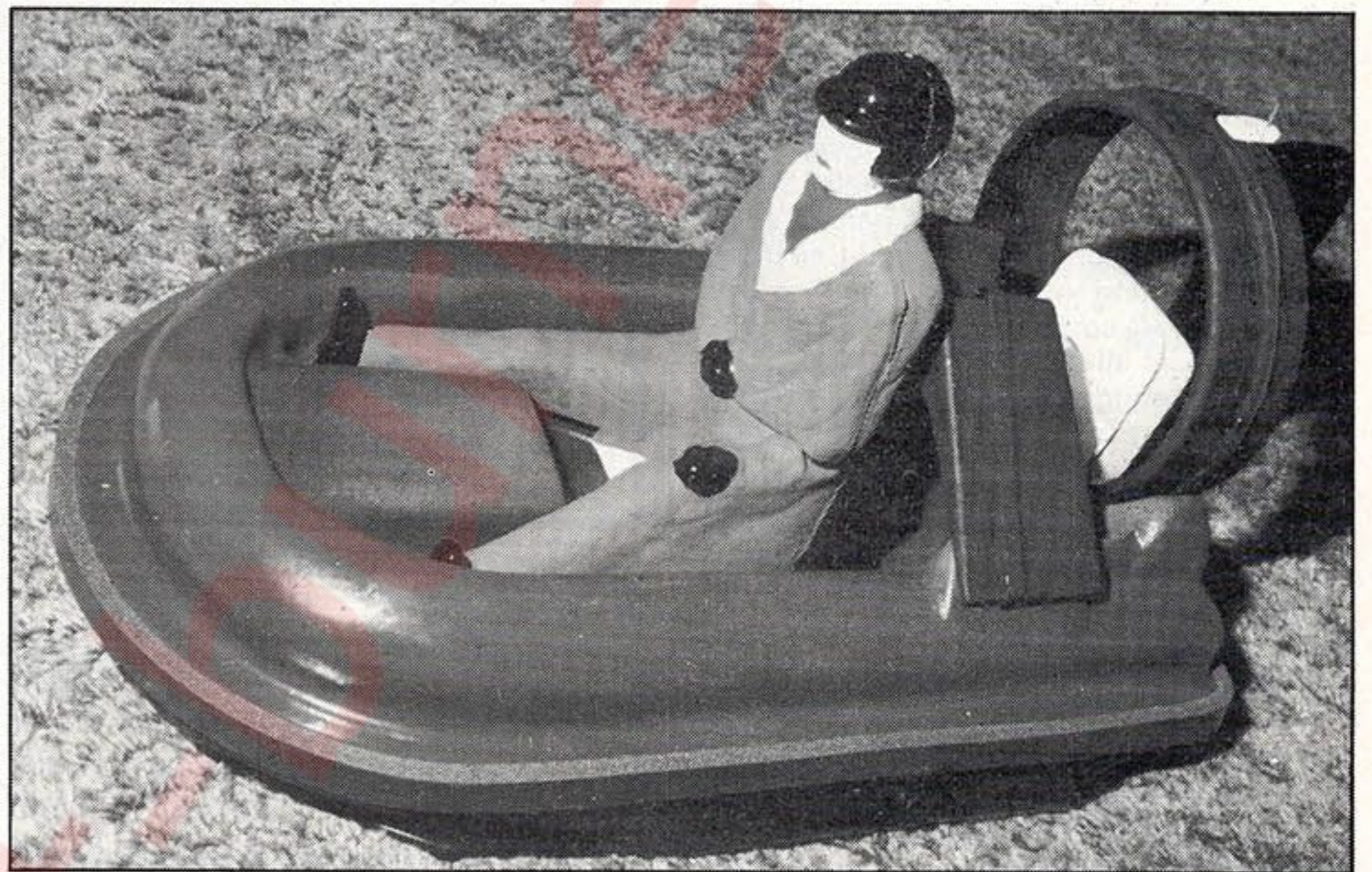

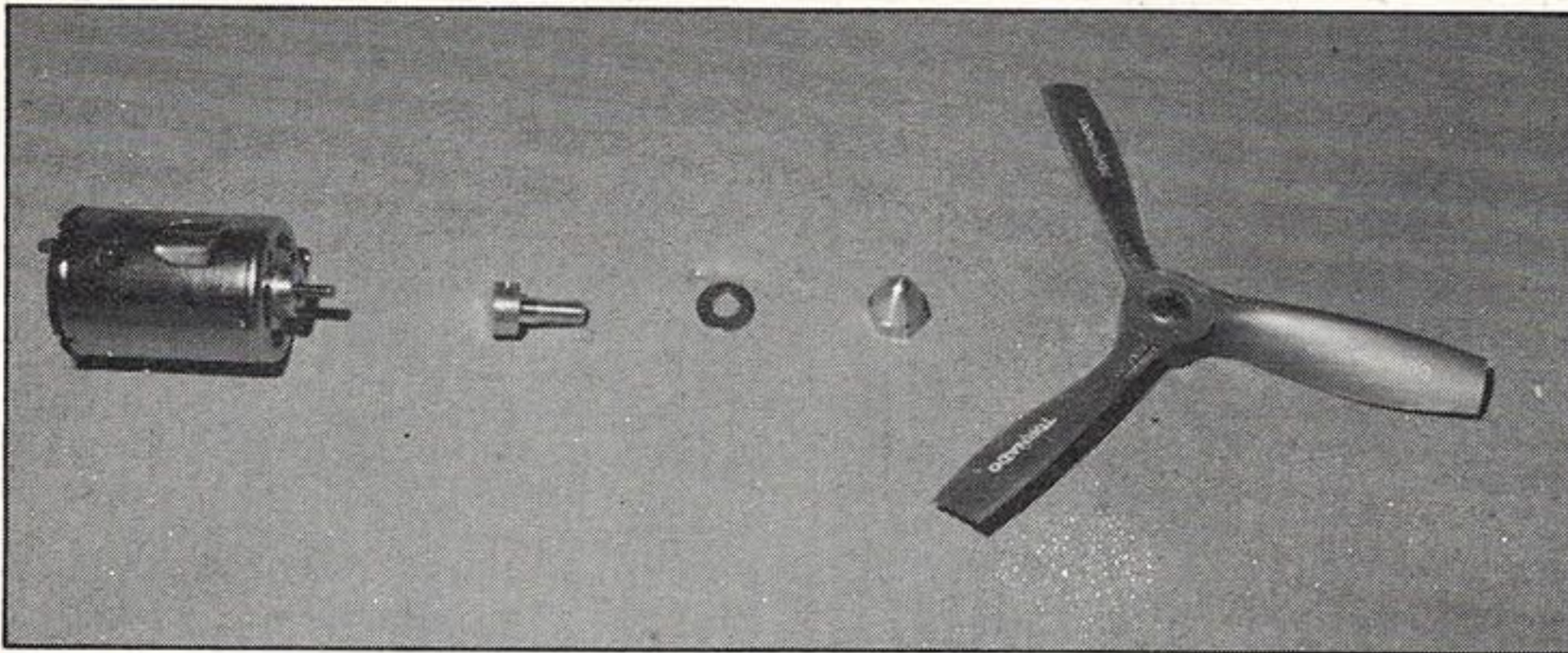

Once all parts are released it is best to sand all edges smooth, two methods of sanding are required here, the first is freehand just following the contours of the moulding, some different diameter dowel is useful here so that awkward corners can be got at. The second method is used for making sure that any moulding that should have a flat edge, or flat edges, actually does. Take a sheet of glass and tape your abrasive material to it, making sure the glass is on a firm, flat base and sand the moulding against the whole thing, this method gives you a flat, secure base or join line every time.

**Enter the Hoverbug**

Sun Lane Engineering Company, better known to all of you as SLEC, have released a hovercraft onto the UK market that may just change the fact that you don't see many of them about. The Hoverbug as the vehicle is named may just have cracked the market because of its means of energy and propulsion, namely a six cell battery pack and a 540 motor of one sort or another.

**Take a Sharp Knife and Begin**

The main ingredient of SLEC's Hoverbug is ABS plastic, this keeps the whole model light and fairly crashproof. All parts are left exactly as they come off the mould, so there is some cutting out to do, don't worry though it's all so straightforward that our example was all cut out in about an hour, and in the lounge whilst holding a conversation with my better half. The best method of removing the sprue (waste plastic) from the moulding that I found, was to lightly score around the piece to be removed and then flex the whole thing, gently prising the score line apart, the plastic then separates fairly cleanly, leaving only the smallest amount of tidying to do. This method saves a lot of bother, plastic has no grain and attempting to cut straight through only results in the blade acting as a wedge and the knife then follows the cut, instead of the other way around.

*Above, a propeller adaptor and locknut is supplied in the kit and holds everything safely in place using a grub screw in the same way as a pinion gear.*

*The driver/pilot is essential as he holds two thirds of the batteries within his shell, use velcro to keep the two halves together. Be sure to drill all exit holes before the skirt is fitted, careful attention here will pay dividends in the long run.*

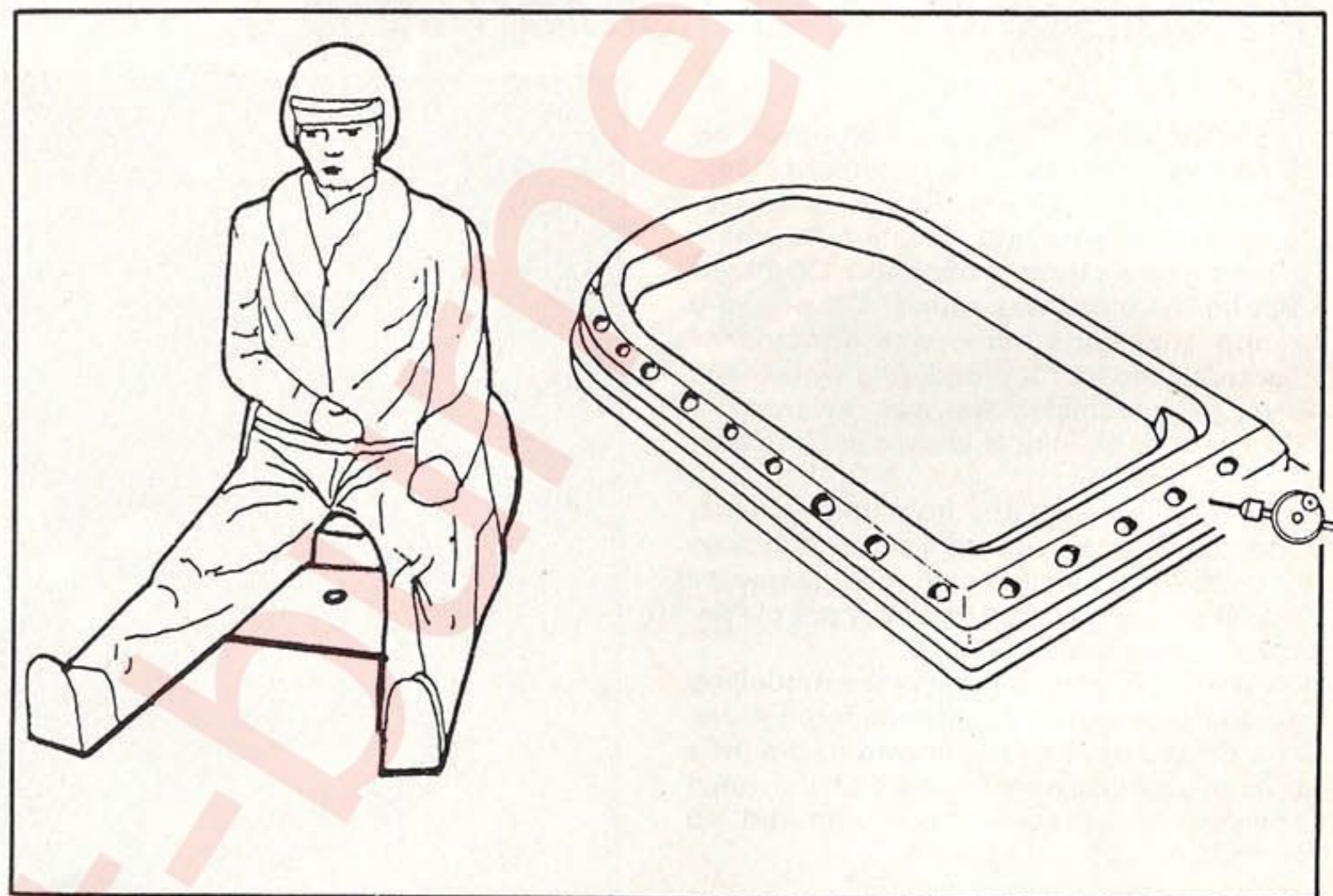

*The finished motor assembly, watch your fingers — propeller speeds are very deceiving and this three blader can build up 12,000 r.p.m. Remember that it will bite.*

*Ready to go, the Hover Bug does look the part when completed and is fun and fast to assemble.*

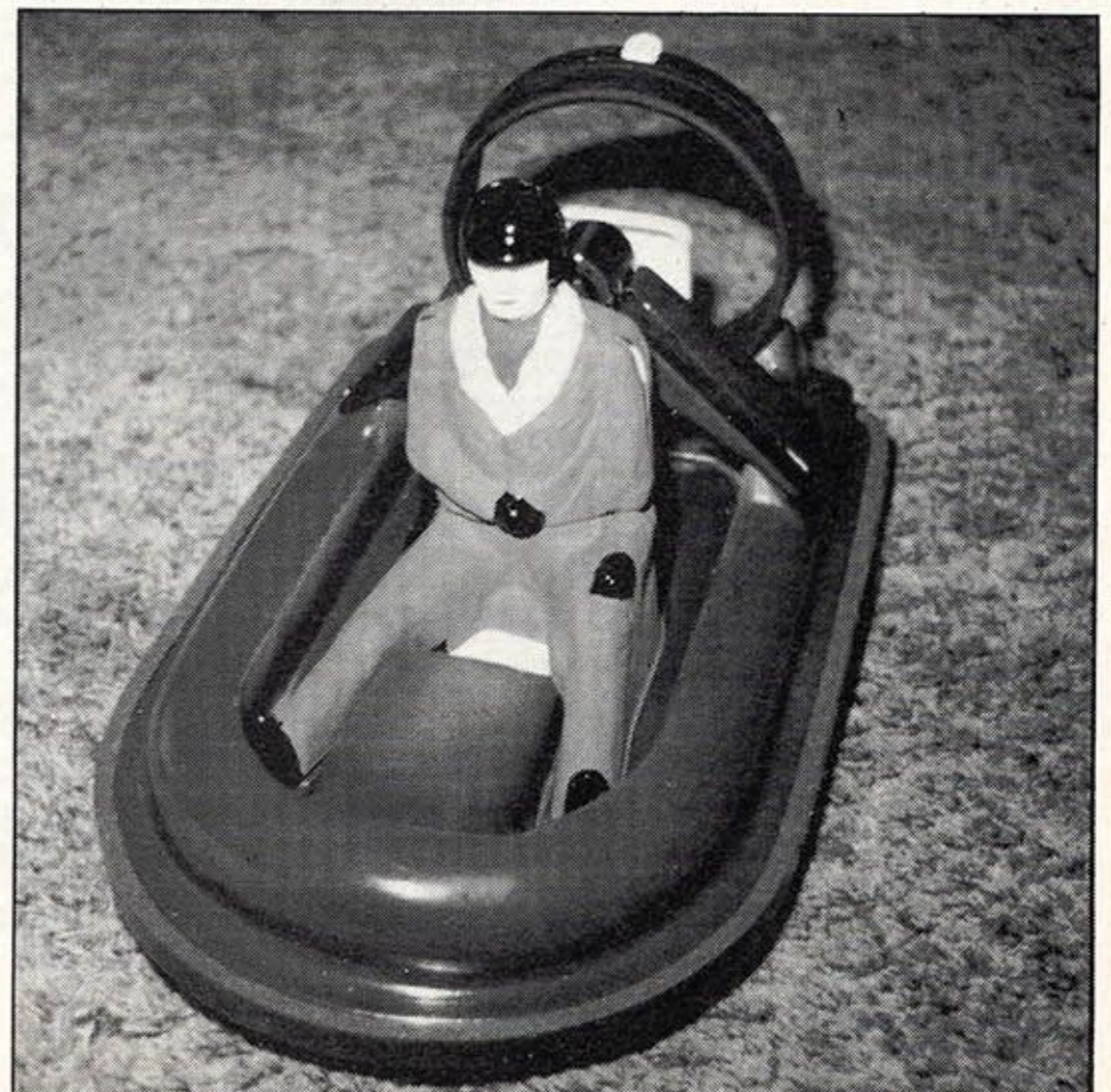

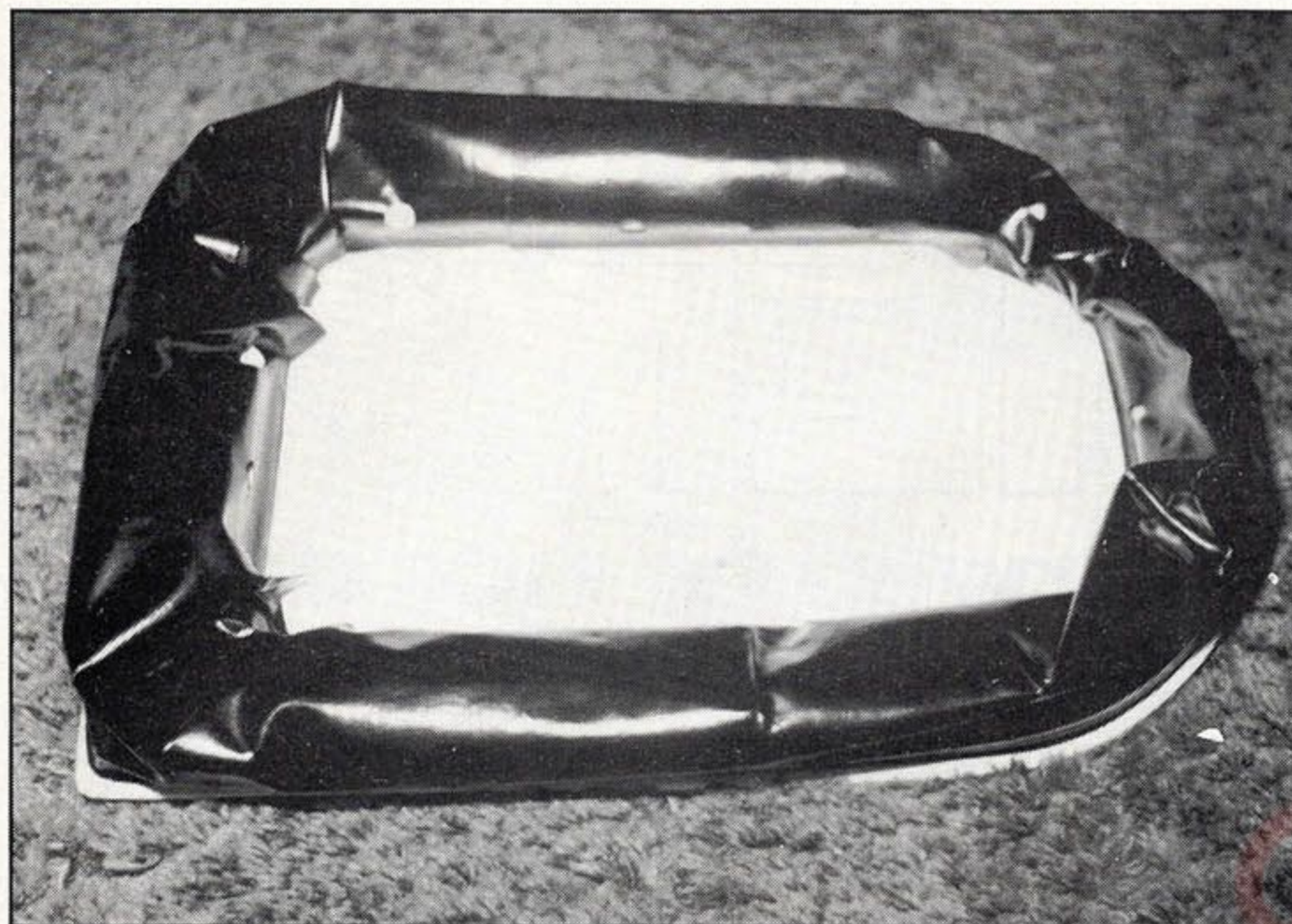

The skirt, this is the device that keeps the Hover Bug aloft. The skirt inflates and excess air is also blown out, helping to maintain lift.

**Stick A to B**

After drilling holes in all the right places, correct positions are feintly marked on the components to be drilled, you can start sticking it all together. Britfix or Humbrol model cement seemed to work best, it's also not a bad idea to hold the parts together using masking tape while the glue sets, this makes sure that nothing slips and dries permanently twisted.

Once the main components are assembled excluding radio, skirt, batteries and motor the whole lot can be sprayed. Any spray paint obtained from your local motor car accessory shop can be used. Apply the paint in thin mist coats, even if it takes ten coats, it's no real hardship as the paint is dry in minutes and you'll obtain a finish like glass.

Once your glass-like finish is obtained fit the skirt, take time here and ensure all holes are properly aligned. Also fit the bumper strip, this is a clever idea as with all bumpers after a while they get tatty or even damaged, with the Hover Bug you just peel the old one off and replace it with a new strip.

**Radio, Batteries, Motor and Propeller**

Both servos are installed using nothing more than servo tape, these are held firmly against the radio bay floor. Do keep in mind when adding all the bits that make the Hover Bug go, that aircraft rules apply and the whole thing must balance at the point described in the instructions, if it doesn't balance then it won't, please note the word was not maybe, perhaps or possibly, but won't work at all.

Installing the batteries again is a simple task, the pack is split into two and four, again hold everything in place using servo tape, remember the balance point will alter if things start to shift when the Hover Bug is on the move.

Motor installation is easy as the photographs show. A standard 540 will make the Bug work but the hotter the motor, the better the performance. Another point worth bearing in mind whilst performance is being mentioned is this, the more blades on the propeller, the better the lift and the thrust, four blades work best and remember to balance the prop before use or you may find your Bug may just shake herself apart.

Once all this is done and the radio and control surfaces have been checked and are found to be working in the right direction, that also applies to the motor, nothing looks sillier than a Hover Bug that's sucking not blowing. You can believe me I know, just don't ask how. Also bear in mind that the rudder also works like an aircraft i.e. viewed from the top when turning left the rudder moves left and right for right hand turns. How does she go? Like walking on air.

Available from your model shop via J. Perkins Distribution or Flair Products. Also available direct from Sun Lane Engineering Co.

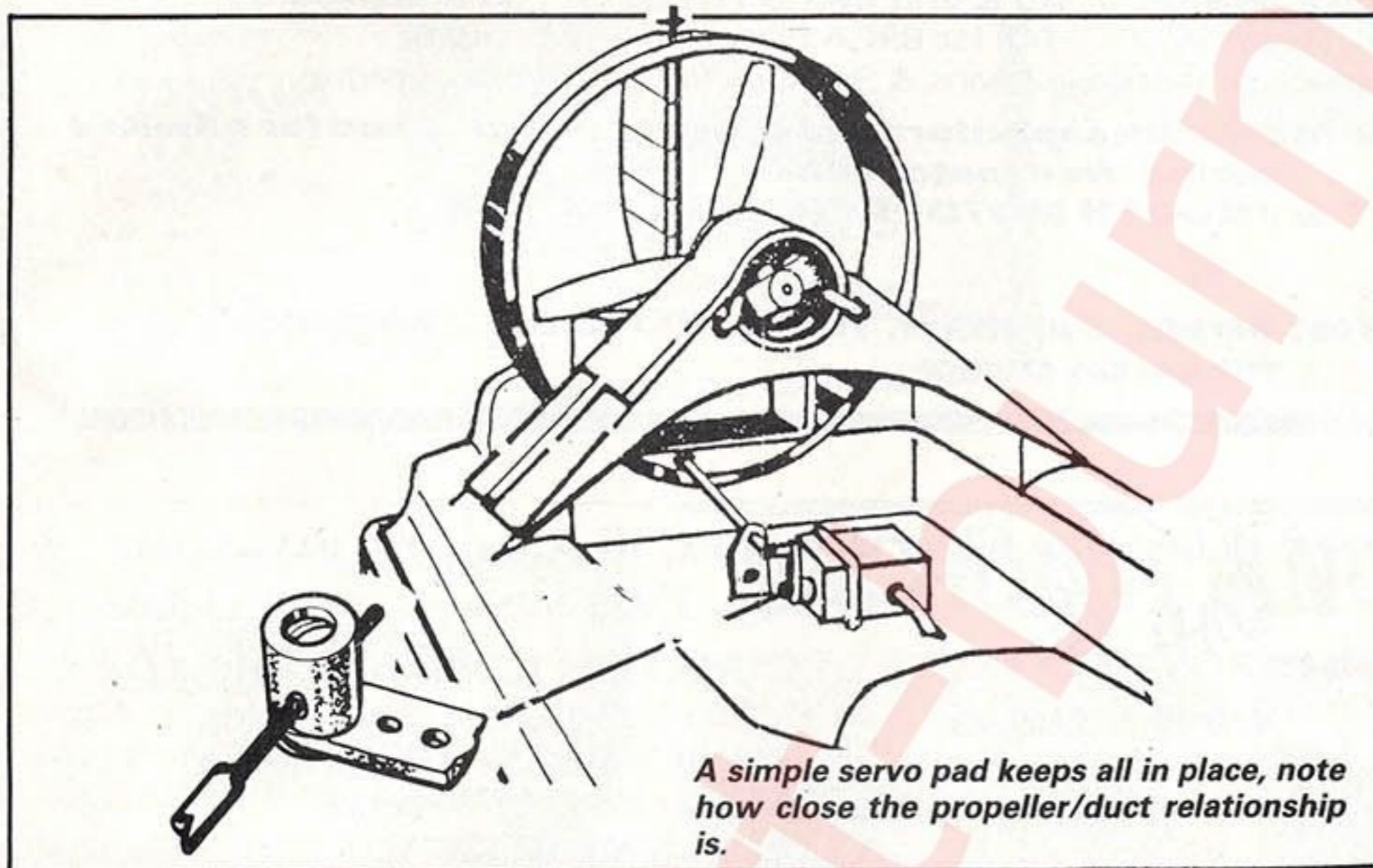

The Bug is essentially built in two halves and held together using a single fixing point.

# TWISTER



## WIN A FREE TWISTER MOTOR

If you find a Red Twister Cyclone stamp in the package when you purchase a Twister Motor we'll send you a Twister Motor of your choice free

### 1/10th TWISTER RACE SUCCESSES THIS YEAR INCLUDE

- ★ Chris Moore, USA — Team Twister — 1987 World Champs. 2WD TQ & 3rd Overall
- ★ Glyn Peglar — Team SRM Laser — TQ & Winner Reedy International
- ★ Glyn Peglar — Team SRM Laser — Winner French G.P. du Beaujolais
- ★ Glyn Peglar — Team SRM Laser — Austrian International TQ & Winner of all 3 Finals
- ★ Denis Blandin — Auto 8 (France) — TQ & 2nd overall French G.P. du Beaujolais
- ★ Jimmy Davis — Team JDM — TQ 1st BRCA National — Worcester
- ★ Simon McRae — Team SRM Laser — 2 wins & 3rd O/A Romsey Winter League

All Twister Motors are supplied fitted with capacitors and superflex leads — and for a limited period 'free motor tub'

ULTRA FAST & SMOOTH MOTORS FOR 1/10th and 1/12th

Sole European & UK Distributor

**SRM Racing** 140 West Street, Fareham, Hants. PO16 0EL, England.  
THE RACERS SOURCE

# INTRONICS



Claerwen, Bexhill Road, Tel: 0323-763688  
Pevensy, East Sussex. or 07918-3263

"CORALLY" SOLE UK DIST, ALL SPARES AVAILABLE

- |   |                   |
|---|-------------------|
| "CORALLY" 1/12 Racing Car               | New Price £169.95 |
| Peak Detect Charger with DVM            | £49.95            |
| Digital Volt Meter 0-20v Panel Mtg. LCD | £23.95            |
| FIREFLY "Sixfet" Full Specification     | £49.95            |
| FIREFLY "GT Buggy" 1/10th Full Spec     | £42.50            |
| FIREFLY 1/12th Full Specification       | £34.50            |

### FORWARDS ONLY CONTROLLERS

- |  |         |
|--|---------|
| FIREFLY "International" ultra low loss | £49.95  |
| Schumacher "CAT" 1/10th Buggy          | £175.00 |

For orders UNDER £10 please add 50p p&p

### SANYO OFFICIAL DISTRIBUTOR

- |   |                 |
|---|-----------------|
| SCR (Red Cells) £19.95                  | Selected £17.95 |
| INTRONICS Motors 27T £11.95, 35T £13.50 |                 |
| GIZMO for easy "FET" set up             | £3.95           |
| CLUBMAN Mk II 7.2v Auto Charger         | £22.50          |
| NEW! 'THERMAL' CHARGER with LCD         |                 |
| Temperature Readout                     | £44.95          |

### RIPMAX FUTABA STOCKIST

We also stock a comprehensive range of Buggy & 1/12th products. Please Ring or send a large SAE for details.

Mini Mustang 1/10th From £139.95

TRADE ENQUIRIES WELCOME

## A.1. BATTERIES CO. SALE ON HEAVY DUTY NICAD BATTERIES

- |   |  |
|---|--|
| Pencells                                | £0.90 each (10 for £8.50), Pencells (tagged) £1.15                         |
| Soft Sub-C (tagged)                     | £1.75 each   |
| Soft VYCS Sub-C (tagged)                | £1.75 each   |
| Ever Ready HP11 (C size) 2.2Ah (tagged) | £3.00 each   |
| HP11 (untagged flat top) 1.8Ah          | £1.75  |
| HP11 (tagged flat top) 1.8Ah            | £2.00  |
| HP2 (tagged) 4Ah                        | £4.00  |
| Rx Packs                                | 220 mAh (25mm dia. button cells) £12.00 500mAh (4 x AA) £6.00 100mAh £3.00 |
| Tx packs                                | 500 mAh (8 x AA) £13.00; 600mAh (35mm dia. button cells) £22.00            |
- 
- |                                 |  |
|---------------------------------|--|
| <b>NICAD PACKS</b>              |  |
| Tamiya 6v 1.2 Ah £13.00         | Soft 6v 1.2Ah £9.00                          |
| Soft                            | 7.2v 1.2Ah Hump Pack £11.00 2 for £20.00     |
| Soft                            | 7.2v 1.2Ah Racing Stick £11.00 2 for £20.00  |
| Soft                            | 7.2v 1.2Ah Apache Type Pack £14.00           |
| Soft                            | 7.2v 1.2Ah Hump Pack £12.00 2 for £22.00     |
| Soft VYCS                       | 7.2v 1.2Ah Racing Sticks £12.00 2 for £22.00 |
| Soft VYCS                       | 7.2v 1.2Ah Apache Type Pack £16.00           |
| Soft VYCS                       | 7.2v 1.2Ah New Racing Pack £14.00            |
| Soft                            | 8.4v 1.2Ah New Racing Pack £16.00            |
| Soft VYCS                       | 8.4v 1.2Ah New Racing Pack £16.00            |
| Ever Ready                      | 7.2Ah 2.2Ah Hump or Sticks £20.00            |
| Soft 6v 4Ah (5 D cells) £24.00; | 7.2v 4Ah (6 D cells) £28.00                  |

Plugs fitted to above packs £1.00 extra. Send SAE for complete list  
Prices quoted on any other Pack. Club Discount. TRADE ENQUIRIES WELCOME

P&P 10% (5% over £20, min. 50p; FREE over £50)

A.1 BATTERIES CO., P.O. BOX 103, STOCKPORT, CHESHIRE SK4 3EW

AVON MODELS  
39 LOCKING RD  
WESTON-SUPER-MARE  
AVON  
Tel: 0934 28305  
CLOSED MON, TUES.  
OPEN SUNDAY

TAUNTON MODEL CENTRE  
6 THE BRIDGE  
TAUNTON  
Tel: 0823 277700  
CLOSED THURSDAY  
RING MAIL ORDER  
TO TAUNTON.

### TAMIYA DEALS

- |                |         |
|----------------|---------|
| STRIKER        | £107.95 |
| FALCON         | £118.00 |
| BIG WIG        | £196.00 |
| PORSCHE        | £203.00 |
| MONSTER BEETLE | £139.00 |
| OPTIMA         | £160.00 |
| SALUTE         |         |
| NINJA          |         |
| BOOMERANG      |         |

### CREDIT CARD/PART EXCHANGE

WANTED: DINKY TOYS, MODEL RAILWAYS, BOATS, PLANES, CARS  
DEALERS PLEASE CALL SUNDAY CLUBS RING FOR DETAILS



Issue No. 11  
Fall/Autumn 1987

USA Price \$3.50  
UK Price £1.25  
ISSN 0012-0715

# TAMIYA MODEL MAGAZINE

**HOTSHOT II**  
The latest Tamiya R/C track buster



**THE MESSERSCHMITT BF109**  
in Foreign Service

**PHANTOM FOCUS**  
Fujimi's F4-M and FG Mk.1



**STALIN'S RED EAGLES**  
Modelling the Yak-9

An inspired choice for the plastic model enthusiast.

All forms of static scale modelling are covered including race and road going cars, military vehicles, fire service vehicles and much, more more for the car enthusiast.

Available from all good newsagents and model shops. Autumn issue available Sept. 18th. Make sure you get your copy, order it today!

All enquiries to Traplet Publications Ltd., Masefield House, Wells Road, Malvern, Worcs. WR14 4PA. Tel: (06845) 60561. Telex 334708 RCMAGS. Fax 068 45 3646.

MODEL MAGAZINE INTERNATIONAL

Colour schemes for the Vought Corsair fighter

Markings and details for the Luftwaffe Junkers 88

Yamaha RZV 500R bike variations modelled

Corsair prototype conversion and service station diorama

Latest radio control cars modelled - plus much more!

Radio Control  
**Video World**

## R/C HOBBY AND MODEL VIDEOS

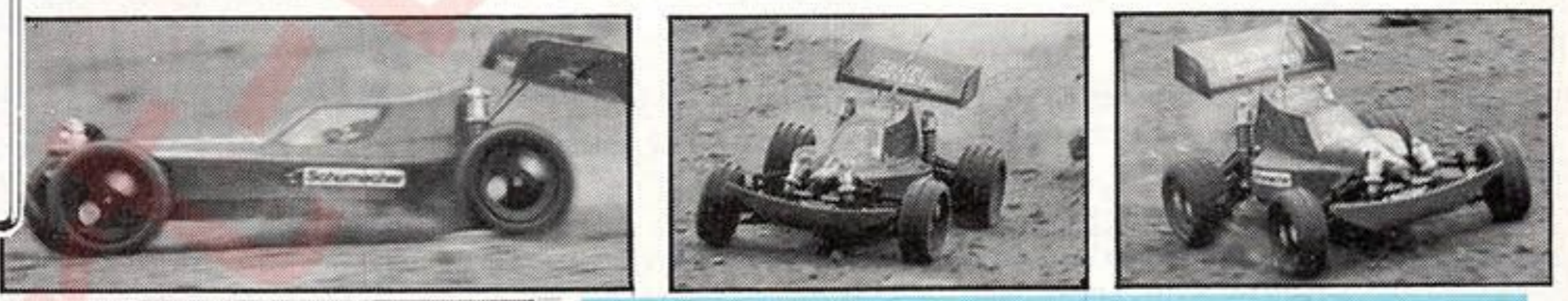

**HEY! DID YOU MISS THE 1/10th WORLD CHAMPIONSHIPS?**

Then why not catch up with the champions and all the latest in the 1/10th off road action in this video of the 1987 1/10th Electric Off Road World Championships held in Romsey, England in August this year.

In this 1 hour (approx.) video R/C Video World looks at the latest cars and technology and interviews the winners and the men that helped them win.

All videos plus p&p £1.00 UK, £1.50 Europe, £3.50 World Wide. All videos available on Beta or VHS (state which required) PAL Format from:  
R/C Video World, Masefield House, Wells Road, Malvern, Worcs. WR14 4PA, England.  
Tel: (06845) 60561 Telex: 334708 RCMAGS Fax: 068 45 3646

Cheque/PO should be made payable to R/C Video World  
ACCESS Welcome VISA



CENTRAL MODELS LTD Official UK and European Distributors of Team Losi High Performance Accessories.

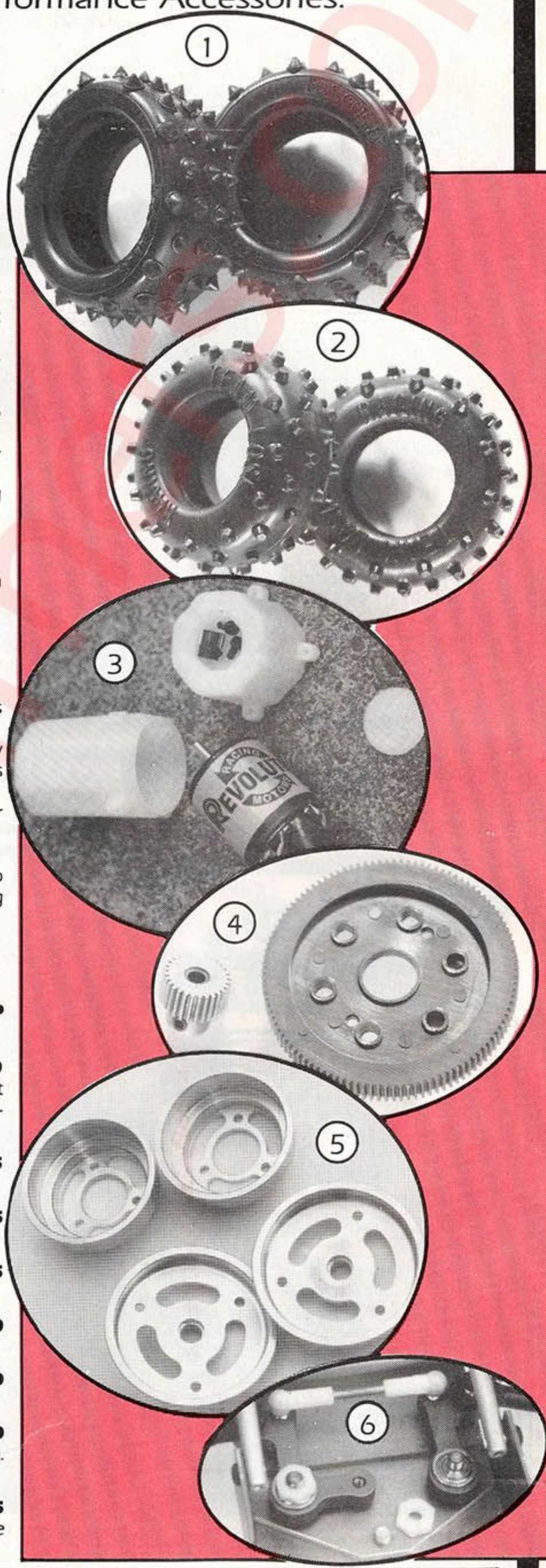

- ① **Eagle super spike low profile tyres fit Hotshot, PB Mini Mustang, Cat, Wild One, Fox, etc. Special Introductory Price £3.95 per pair**
- ② **TL 5010 — Losi Super 'High Grip' Rear Spike Tyres —** Fits RC10, Yokomo, Optima and many others. Used by Gil Losi Jnr. to win world title. **£6.95**
- ③ **NEW — Losi 'Motor Safe' Containers TL 6059 —** Unique storage container for motors. Motor 'suspended' in container allowing pinion gear to be left on without damage to armature shaft. Octagonal shape will not roll off pit table. Top and bottom of container is 'keyed together' on assembly, producing a secure lock. Storage compartment in lid to hold spare brushes springs and screws — A MUST. **£1.95**
- Team Losi Modified Motors — £40.00 —** built with world champion Yokomo components — **nothing but the best!**
- Team Losi Revolution II 21 Double** (Ideal 2WD motor, easy to drive, also fine for 4WD)
- Team Losi Revolution IV 19 Double** (Excellent 4WD motor good top end and duration)
- Team Losi Revolution 'Oval' 17 Triple** (For all out speed, but still controllable)
- Team Losi Revolution 'Insane' 15 Double** (For ultra fast high traction tracks)
- Team Losi Revolution 'Superstock' 28T — £14.95 —** (Features all the custom tweaking allowed to be done)
- Team Losi Primetime Matched Sanyo's — £22.00**
- ④ **Team Losi 64 Pitch Pinions and Spurs —** 18 to 36 pinions **£4.50**, and 96 to 108 spurs for super smooth transmission — **£4.25**
- Team Losi RC10 Racing Accessories**
- Diff Tube with ballbearing — £8.95 —** (to eliminate slop and wear of stock bushes resulting in smoother drive and prevents stripping of 64dp spurs)
- ⑥ **Bellcrank Kit with Bearings — £21.95 —** (Replaces nylon cranks and alloy screw posts with alloy cranks fitted with two ball bearings mounted on hardened steel posts for super smooth no slop steering)
- Bellcrank Kit with Bushes — £12.95 —** (Same as above but with bushes rather than bearings)
- ⑤ **RC10 Aluminium Wheels — £11.95 pr. —** Sprint, Front Slot, Rear Slot
- Tyres 1/2 front £4.30, and rear £3.35, medium or soft. 1/10 Team Losi Super Grip tyres for RC10 rear or Optima front and rear £6.95. Fit many other cars providing excellent grip and wear.**
- Miscellaneous**
- Competition Modular Brushes (Silver Type) **£1.95.** Competition Cut Brushes (Silver Type) **£3.50.** Yokomo Silicone Wire **£2.50.** Motor 'Cool' Covers **£1.25.**
- TIE WRAPS 100mm x 2.5mm. Pack of 10** **60p**
- We are also main stockists of Novak Electronics**
- NOVAK — NES — 1 Speed Controller** **£85.00**
- One of the most technically advanced speed controllers on the market, using the highest quality components throughout. Voltage loss 0.0025 (V/A) providing maximum acceleration and top end speed. Forward only — 1.25oz
- NOVAK — NES — 4 speed controller** **£61.95**
- Superbly constructed. Will handle the hottest modifieds. Forward only — 1.25oz
- Speed control heatsinks** **£8.55**
- An optional extra for your NOVAK controller but essential for off road conditions.
- NOVAK — NER — 2S Receiver** **£36.75**
- Compatible with Futaba G plugs. Ultra small and light — 0.750oz
- NOVAK — NES — 1A Servo** **£28.60**
- 21 inches torque. Super fast. Ideal for 1/12th and 1/10th alike. Very light — 0.98oz
- NOVAK TEMPERATURE CHARGER NEC-1** **£45.00**
- Heat sensing for most accurate charging. Adjustable temperature cut off and amp rating.
- NOVAK PEAK CHARGER NEC-2** **£58.00**
- 3.0 amps or 4.5 amps constant current rates. 3.0 amp charge rate is adjustable from 0. to 3.5 amps. Circuitry protected by automatic circuit breaker.
- NOVAK PEAK CHARGER NEC-2P** **£89.95**
- Same as above but with built-in volt/ammeter with plenty of adjustment. Possibly the best peak charger available?



Mail Order Welcome Dealer Enquiries Welcome

Send large SAE for full list, details and prices.



**Central Models Ltd., Unit 11, 16/20 George Street, Birmingham 12 9RG. Tel: 021 440 2677**

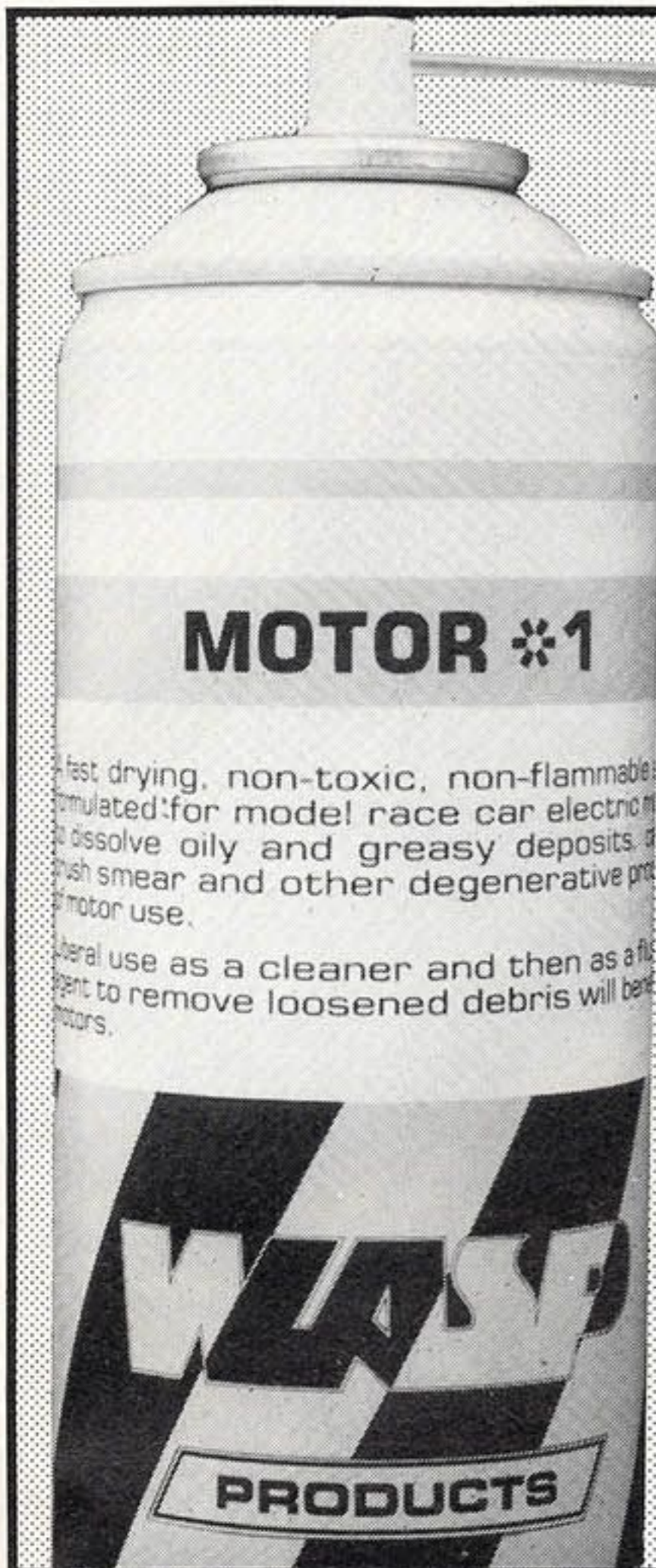

**MOTOR\*1 & FOAMBUDS — THE PROFESSIONAL MOTOR CLEANING TOOLS**

Throw away those cottonbuds — with a FOAMBUD fitted directly to the spray head of MOTOR\*1, the safe yet powerful cleaner can be applied direct to the commutator and soil removed on the microporous tip of the FOAMBUD. When removed from the motor, the FOAMBUD can be blasted clean with spray pressure and used again. FOAMBUDS actually fit into the brush holder and will not leave tufts or shreds of cotton inside. Developed for the model racing enthusiast, FOAMBUDS are a cleaning tool. First shown at the World Championships at Romsey, FOAMBUDS are now available to all racers. MOTOR\*1 "THE" motor cleaner and FOAMBUDS are available from leading model stores or direct from WASP.

FOAMBUDS: £1.20 pack of 5 (+ 20p p+p)

MOTOR\*1: £4.95/600gm can (+75p p+p)

**ANYONE FOR TRUCK RACING?**

Ideal for carpet or flat surface racing, the WASP MINI-TRUCK kit provides the bodyshell and 6-wheel chassis plate with instructions for building a racing truck from a Mardave mini stock. Also required are an extra pair of rear mini wheels/tyres with axle and mounting blocks.

Chassis with bodyshell and instructions (supply your own extra rear wheels etc) £12.00 + £1.00 p+p.

Extra wheels/tyres/axle/mountings etc. £6.00 (+ 50p p+p if not ordered with chassis).

Trade Enquiries welcome

WASP PRODUCTS LTD.,  
13 MORNINGSIDE ROAD,  
WORCESTER PARK,  
SURREY KT4 8LQ  
Telephone: 01 337 2921



**M.G. MODEL PRODUCTS**

91 Clearmount Road, Weymouth, Dorset DT4 9LF  
Tel. 0305 772048

**RESULTS** 5 July Radio Race Car Round RAF Cosford 1st James Barker 16 turn Triple MAGNUM. 26 July Chesham 1st & 3rd MAGNUMS. July 26th EVER READY CLASSIC SERIES. BRCA NATION MEETING. FTD 1st Mike Bridges. 2nd James Barker MAGNUM POWER. 2nd August BRCA Modified Championship Woodvale 1st Mike Bridges MAGNUM.

**STOP PRESS** 16th August SRM World's Revenge Meeting, Stafford. 1st Mike Bridges, Magnum 16 Triple Nosram hi energy cells/controller

**NOSRAM PRODUCTS** Nosram high energy matched and pushed cells, cells alone (not made up) 6 for £30. Made up price T.B.A. Nosram temperature sensitive charger £45. Nosram speed controller rugged with all extra facilities £67.95

**BUGGY SPECIAL BROWN DOT** BRCA '87 Spec. Standard. 27 turn 22 AWG Bal./true/advanced (very?) £12. Optional extras @ purchase, but after £12 transaction. Contoured brushed £1.50, Zapp £2.

**87 BRCA 1/12th STANDARD** 35 turn 23 AWG Bal/true/adv. selected motivation £13.50.

**NEW SPEC RED DOT** 17 turn double oilite/tags all extras. £17.95. Available in 17 double, 18 single, 19 double winds.

**NEW RED DOT +** Full ballrace, detachable end bell, 17 turn double armature semi handwound (actually machine wound, but wire controlled on m/c by hand for better wire layering than m/c job) £25.95. Available in 17 and 19 turn double, 18 and 27 turn singles.

**NEW ADDITIONS** to gear range (all 64 D.P. fine teeth hard)  
RC10 type (use 1/8" balls not 3mm) 108, 110 & 112 teeth. £6.76 each  
RC12 type (use 1/8" balls not 3mm) 90, 91, 92, 93, 95, 97, 98 & 99 teeth £6.50 each  
Carbon fibre to suit Corally/Schumacher 95, 97, 98 teeth £5.55  
Pinions, hard, long pattern: Corally-Schumacher 20-30T £4.20 ea. Short RC10 etc. 17-30T £3.75 ea.

**MAGNUM FULL MODIFIEDS** A full range of specifications from 28 turn quad to 15 quad, to suit all 1/10th and 1/12th uses. Usual quality/consistency. See what the top non-sponsored guys use? £39.95

**LEAD WIRE** 1 meter red 1 meter black. £1.50. **CELLS** Sanyo yellow sticks select Scorpion etc. config. £16.00

**MOTOR SERVICES** Well it had to happen. Until further notice we will only be able to rebuild our own full modified and Red Dot + units. PRICES: rebuilding including ball/true/Zapp £7. Rebuild & replace brushes/fit £9.50. Replace ballraces £2.50 each. We should now be able to turn this work around in 3/4 days. If unsure of the cost of rebuilding your unit make cheque out "Not exceeding Twelve Pounds" and we can fill in charge appropriate.

We are now able to supply a limited number of additional retailers  
Ring for Details



Postage under £10 - 50p. Over - free  
TRADE ENQUIRIES WELCOME



**BAGNALLS MODELS**

18 SALTER ST  
STAFFORD

Tel. (0785) 223349  
Closed Wednesday

WOLVERHAMPTON ST  
WALSALL

Tel. 0922 23984  
Closed Thursday

Mail Order to Stafford only

**OFFER**

**DISCONTINUED LINES**

**1**

	Kit	Deal
Hotshot .....	£69.95	£129.95
Grasshopper .....	£37.95	£89.95
Suburu Brat .....	£44.95	£99.95

HURRY LIMITED STOCKS ONLY

**OFFER**

**FABULOUS TAMIYA DEALS**

**2**

Hotshot II, Striker, Monster Beetle, Falcon, Hornet, Porsche, Blackfoot, Boomerang, Vanessa's Lunch Box

We believe our deals and prices are the best value available. Phone us now you won't be disappointed!

**OFFER**

**FABULOUS KYOSHO DEALS**

**3**

	Kit	Deal
Optima .....	£119.95	£179.95
Rocky .....	£94.95	£159.95
Ultima .....	£94.95	£159.95
Cosmo .....	£74.95	£134.95

**FREE OFFERS WITH ALL DEALS THIS MONTH  
PHONE FOR DETAILS**



# CYBON 1

Dave Pearson looks at Rainbow's Robot

Before you turn the page just wait a minute and take another look. Yes you are right, this is a magazine for racing cars, but it is also a magazine for race car enthusiasts no matter what their age. The Cybon 1 is a radio controlled car that is aimed at the huge divide that lies between the toy and the serious radio racing car market, it is also a radio controlled car with a difference, more about that later.

Obviously no serious racer will think about buying the Cybon to thrash around the race tracks of the U.K., but the one great problem area that all radio involved sports has had over the years, and will always have, is attracting the newcomer as a youngster, so that by the time he or she is of an age to compete, the feel of a radio has been acquired and the enthusiasm is high. What better way than something such as the Cybon, the car is big, huge balloon style, deep V ridge tyres supply traction, they also supply the suspension for the rear end. The main car body is moulded in bright red plastic, again a very eye-catching colour for any youngster. A yellow roll cage finished the car off giving it both a bold and off road appearance.

Front end again is moulded plastic with springs fitted to assist damping.

*The heart and soul of the car is the driver, move the transmitter stick and watch his arms go.*

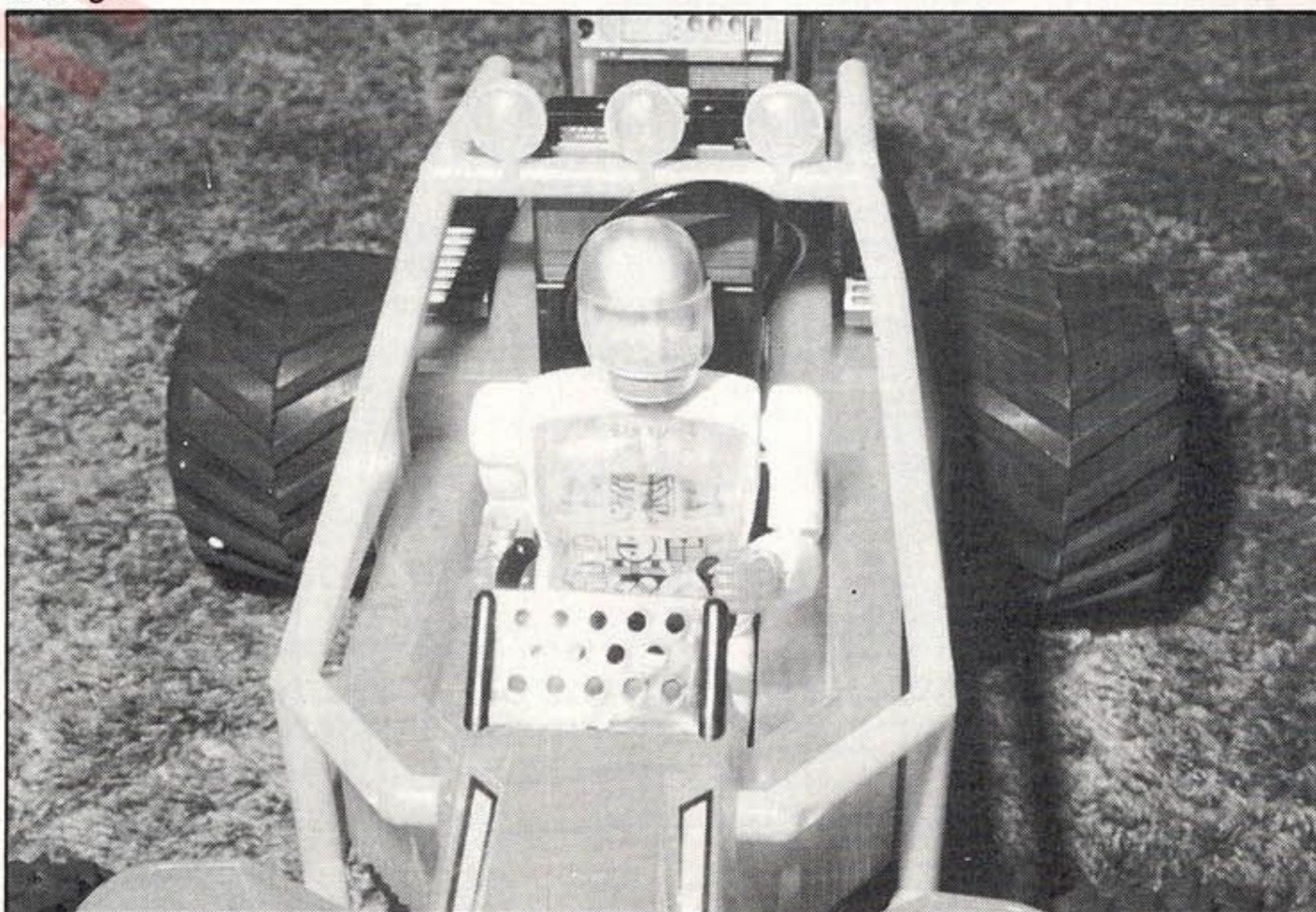



Front end is aided slightly by coil springing which works well on flat ground.

A winch is also included on the Cybon, this adds to the play value.



### Spot the Difference

Heart and soul of the car is the driver, this is what makes the car go, literally, move the transmitter sticks and the driver's arms move both steering wheel and speed controller. The car's internals are well hidden but the speed controller seems to be of the sliding resistor type *a la Marui*. Bringing things down to basics, the driver is no more than two servos built into a human figure, rather than a black plastic case, a novel idea. Play value is also increased as all gear wheels can be seen moving, its also rather nice to see a driver's arms moving furiously as the car steers, stops and reverses. The driver's back pack, which is firmly secured to the car by two clips is the receiver and a firm on/off switch is located on the top where any one can reach, including young inexperienced fingers. Battery power is as follows, four pen cells for the receiver and eight C cells for the main drive. This sounds over the top but as the car is used mainly by the younger driver then long battery runs

are essential. Also a major plus point here is that the Cybon uses rechargeable cells and a charging jack is fitted, this facility will save pounds in extra batteries.

### Transmitter

A transmitter is provided in the Cybon package and has a claimed range of one hundred yards. The transmitter is a very neat piece of equipment and is very close to Dad's or older brother's real one, again a plus point, every ten year old wants one just like Dad's after all. A firm safely placed on/off switch is mounted centrally in the face under an L.E.D. indicator. As in all transmitters throttle is on the left and steering controls are on the right, trims are also provided. Battery power is by one P.P.3 again giving about one and a half hours use.

### Under Power

What better way of testing the car than under the ideal conditions, for this my son was employed, well actually my son and I

played with the Cybon 1 and enjoyed ourselves for about a half an hour continuously before we lost all motive power. It proved, however, that the Cybon does fit the bill for which it was intended. As he saw the Cybon his eyes lit up and he couldn't keep his hands off. After he was forcibly restrained we were away to the garden and the Cybon was trimmed to give proper neutrals on both channels, this was easily done using the transmitter, and off we went. As already stated being able to watch the driver's arms move did add to the overall fun and after all that's what playing is all about. As a bonus, if the cars play value leads to another R/C racer entering our fold then that has got to be good.

For further information contact: Louise Cranna/Pippa Smith on 01 437 7733.

Cybon 1 will be available from major department stores and toyshops. Price £149.00.

The driver grips both controls and works them with a vengeance.

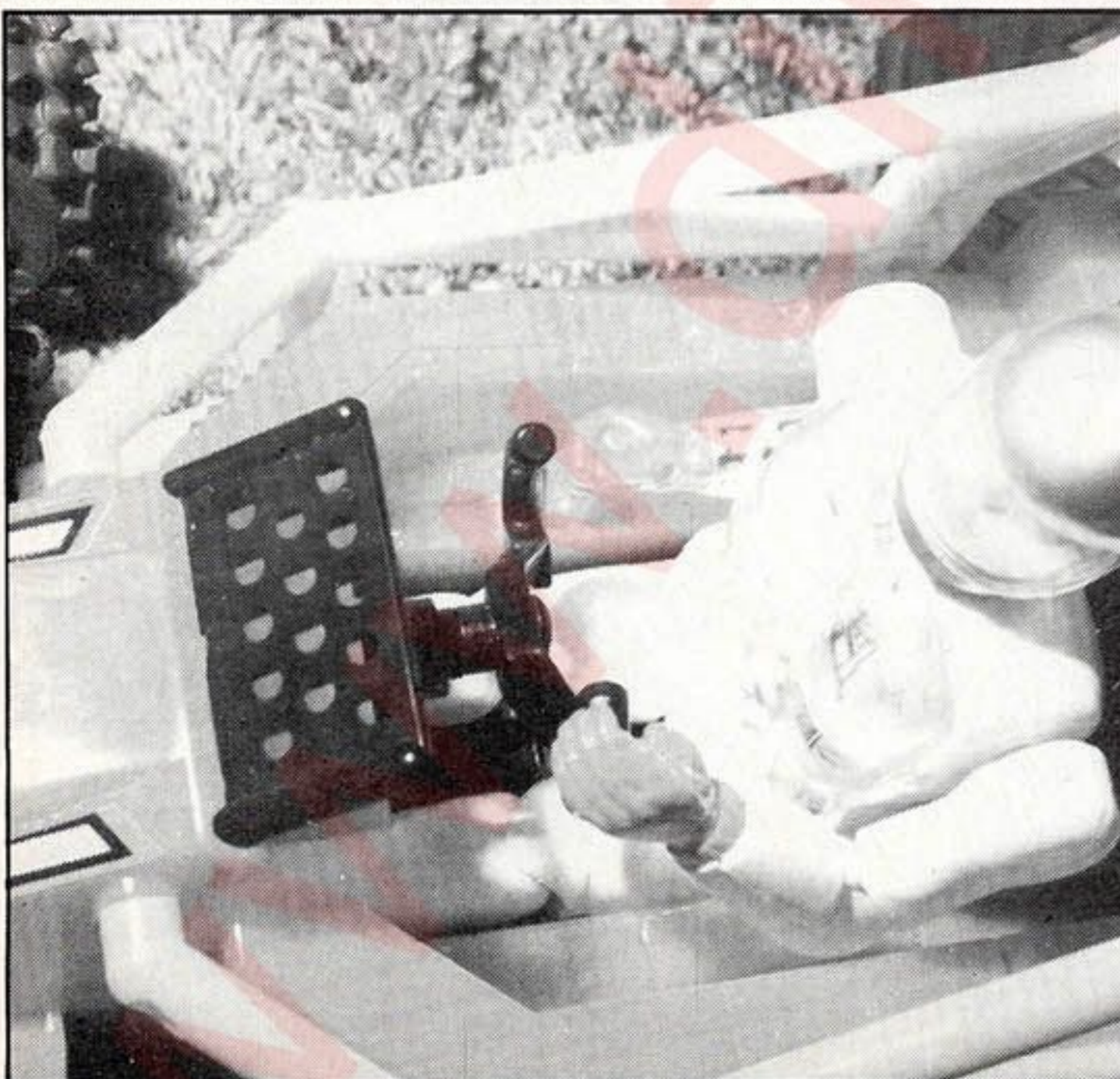

The Cybon comes complete and ready to go, also included in the package is a two channel transmitter.



# MARKET PLACE

### Index Link

Ever use your back issues for reference? We do and until lately the situation was something like this. "Do you remember that thingy article, you know the one featuring the Klakibonko 540, it appeared about March, or it could have been June". You know how it is. Well now you can end all that confusion and misery simply by sending for a copy of the Radio Race Car Index. The index is divided into logical sections such as reviews, regular features, etc., and covers every topic mentions in R.R.C. back issues.

For further information write to Doug Sim, Thistledown, Spy Lane, Hoxwood, West Sussex RH14 0SQ.

Market place this month features new products from the 1/10 World Championships. One company that had a host of new items on show was P.K. Model Racing. First on their list were two new chassis by Corally, both were designed around Schumacher cars, the C, 1/12 car and the all conquering CAT. Both of these chassis are manufactured in high quality, aircraft grade alloy, ensuring that the car always has a precise base from which to set the suspension up from.

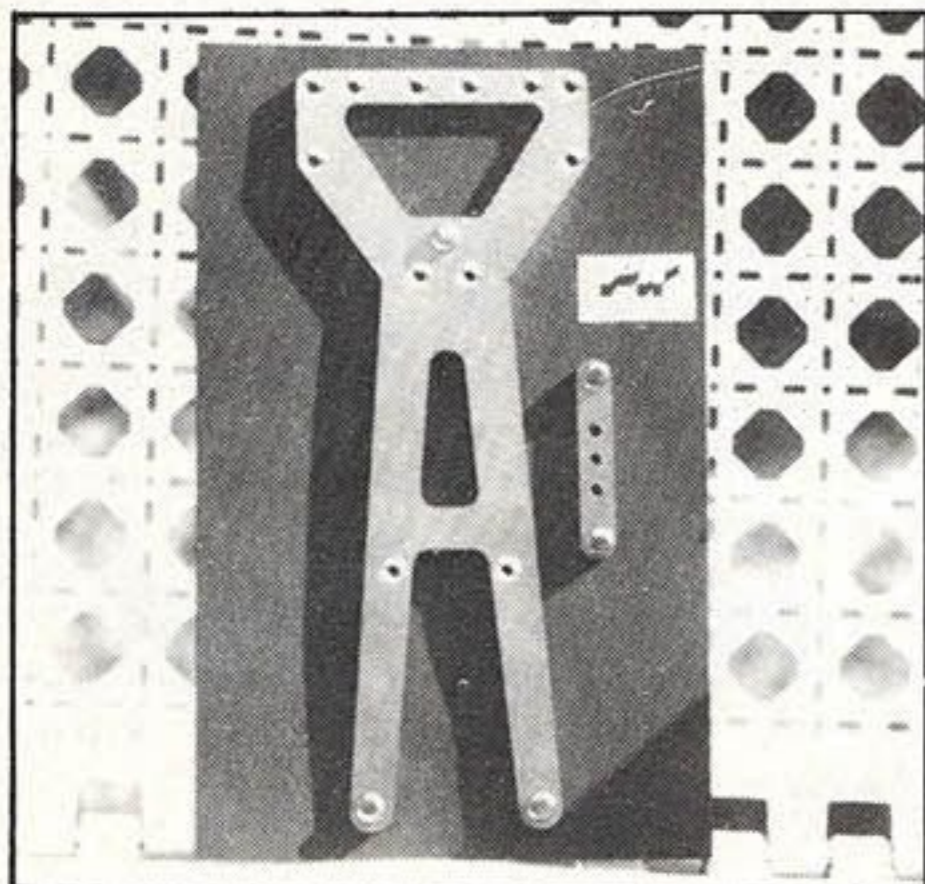

### Trinity

It is claimed that 20 to 30% less drag can be obtained by using these new 64 pitch, graphite filled spur gears in conjunction with the low friction plated pinions by Trinity. Spur gears range in sizes from 98 teeth to 108 teeth. Pinions range from 18 through to 36 teeth. Judging by some of the results the Trinity team were achieving throughout the world champs, they work!

**TRINITY**  
*POWERED*

**"STOP FRICTION FROM EATING POWER!"**

TRINITY MAGIC 64 PITCH GEARS  
GRAPHITE FILLED SPURS

LOW FRICTION PLATED PINIONS

**20-30% LESS DRAG**  
*'We are the competition!!'*

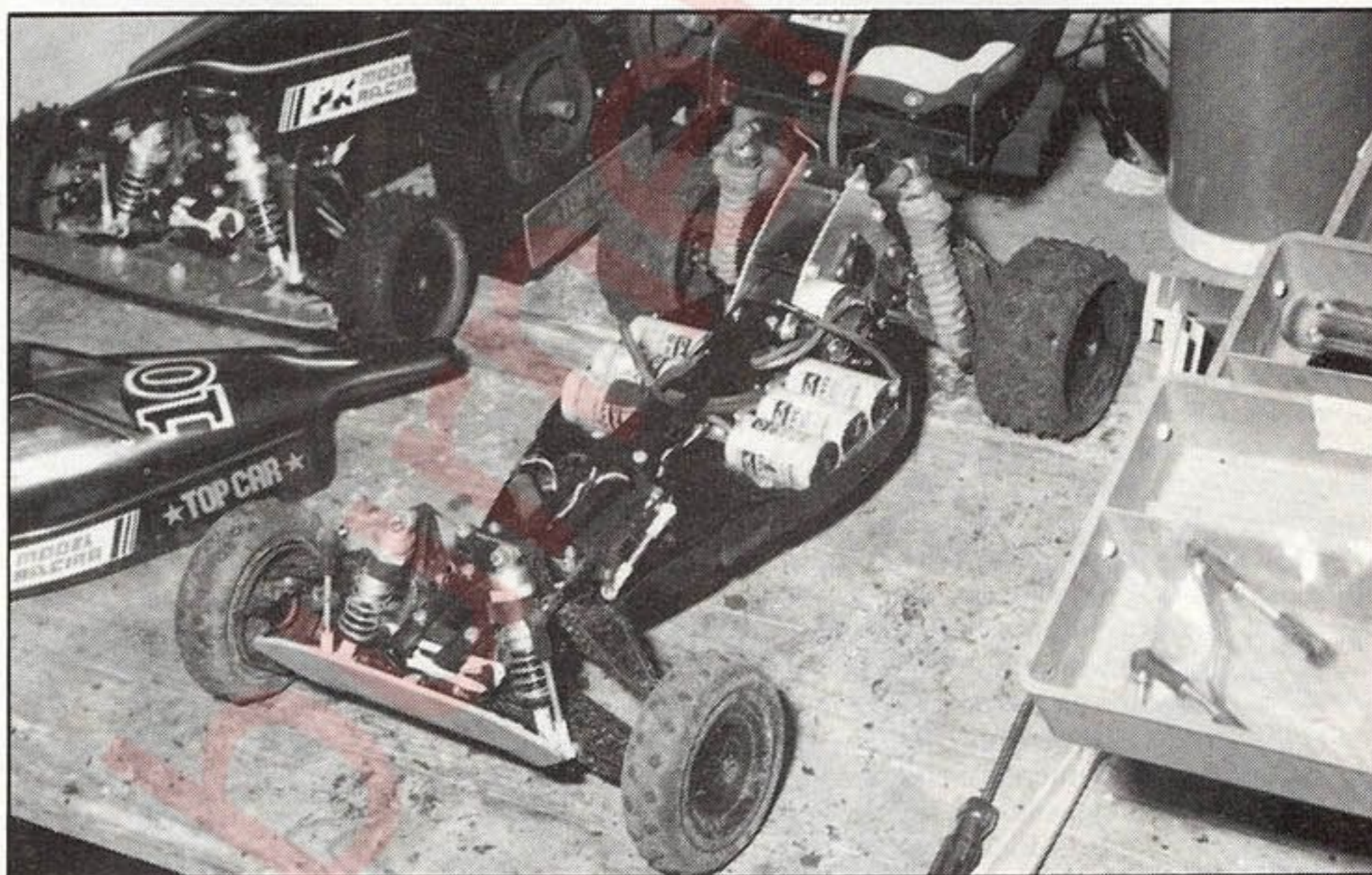

### Tweaker Board

Talking of setting suspension correctly, how about this then, also from P.K. Model Racing is this superb tweaker board for 1/10 cars. The tweaker board allows you to precisely set your car up so that the whole suspension system is finely balanced, wheel

alignment and tracking can also be adjusted using the same equipment.

Tweaker board and both chassis are available from P.K. Model Racing. J. Van Kooy, Laanstraat 116, 3743 BJ Baarn, Holland.

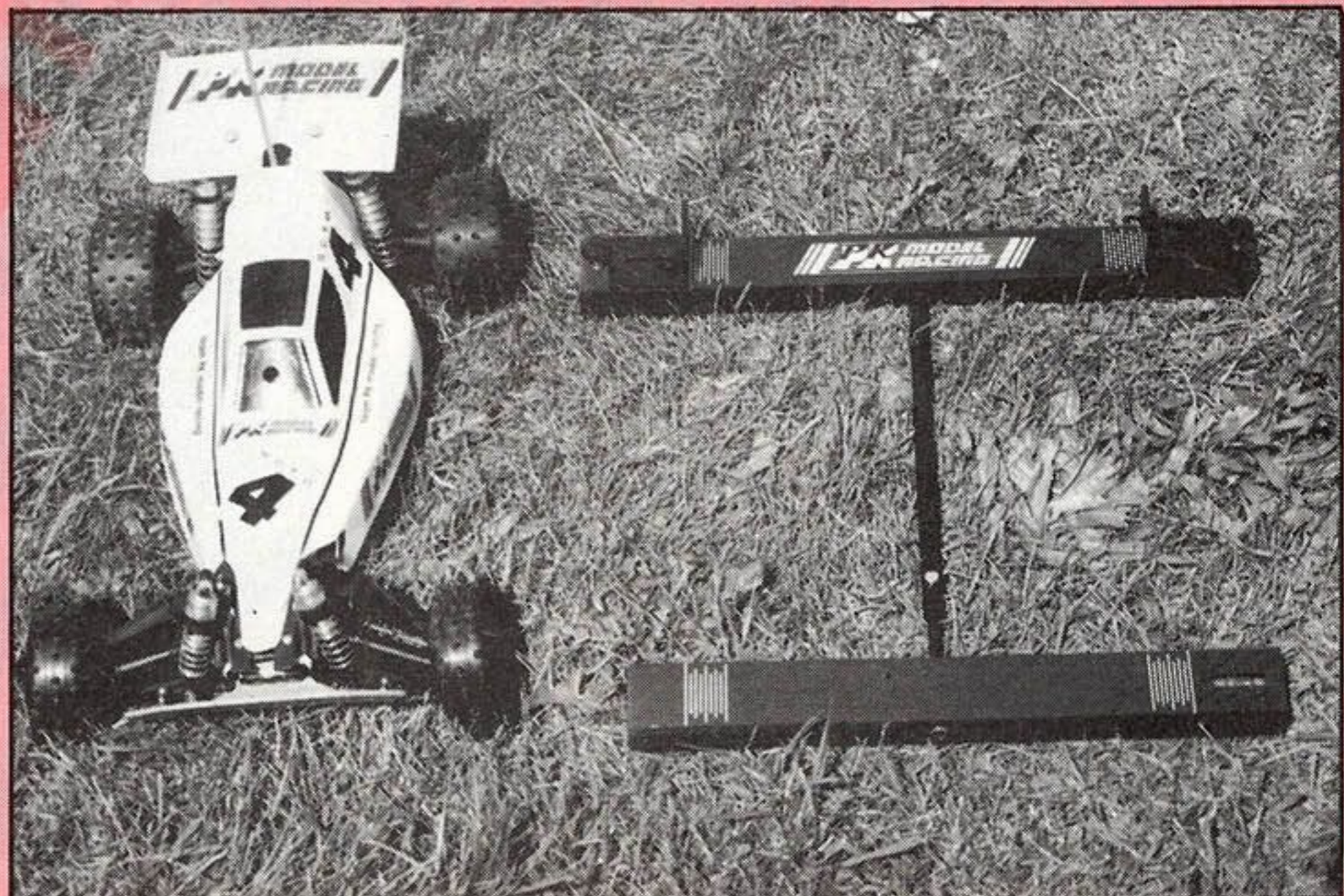

**Tekin Products**

Tekin were also showing, as well as using some of their equipment to good effect at Romsey, amongst the electronic gadgetry was this mini, mini receiver. Pictured here beside a two pence piece, and yes it is a real one, you can see how compact the new receiver is. No technical details or release dates are available as yet so keep watching this space for further information. Also new from Tekin the new 200 Pro Charger featuring a digital Amp/Minute readout and the Mospower speed controller. The speed controller is a very interesting item utilising eight F.E.T.'s and coming complete with on/off switch and heat-sink.

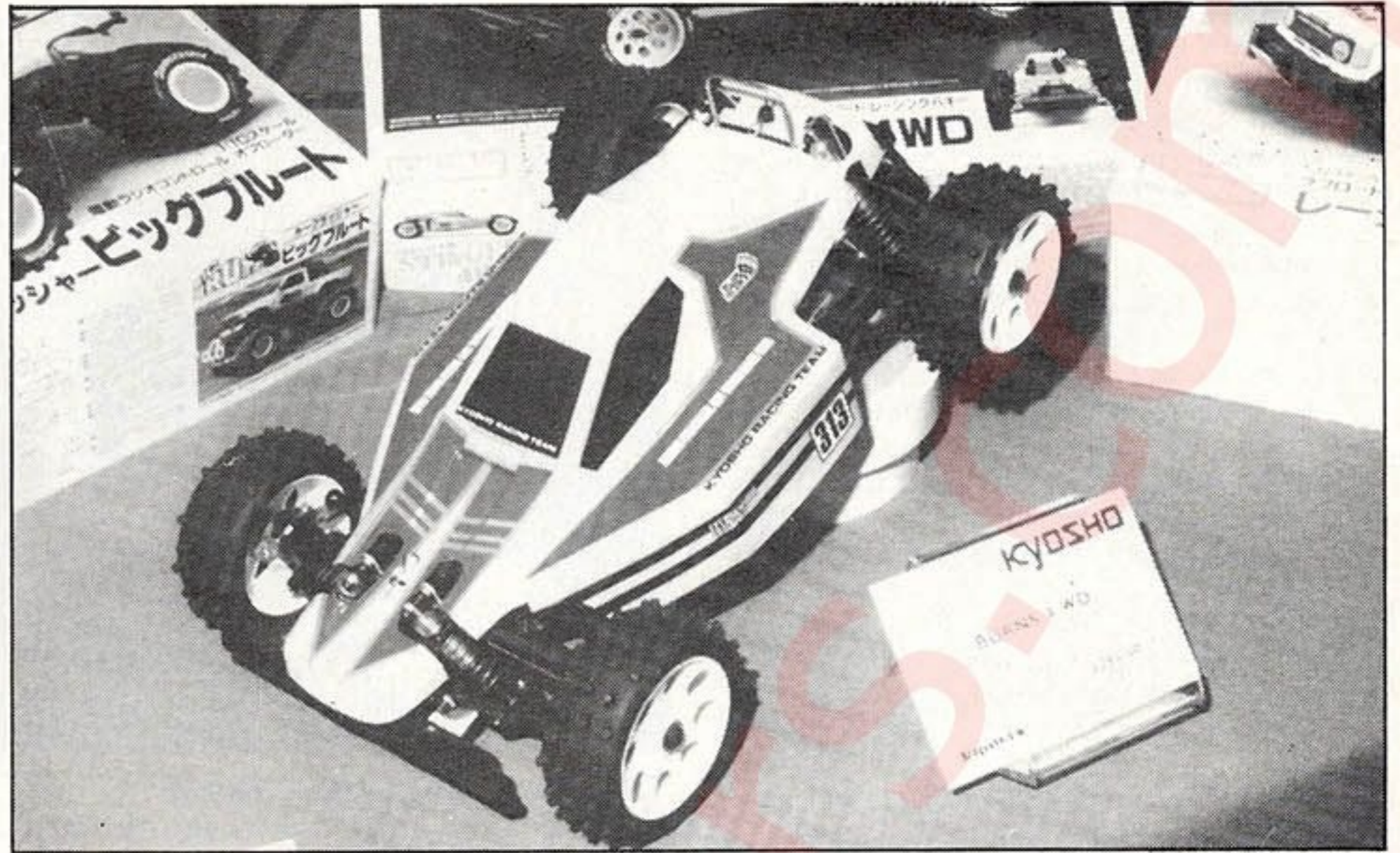
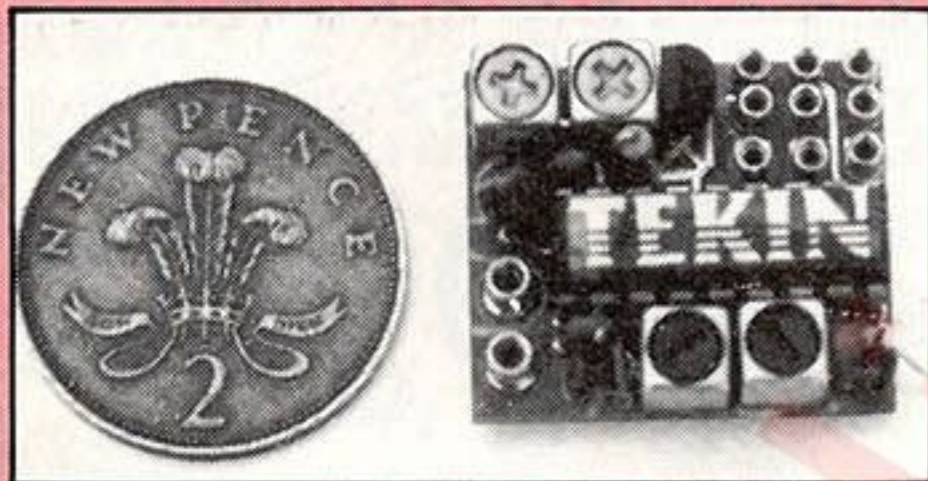
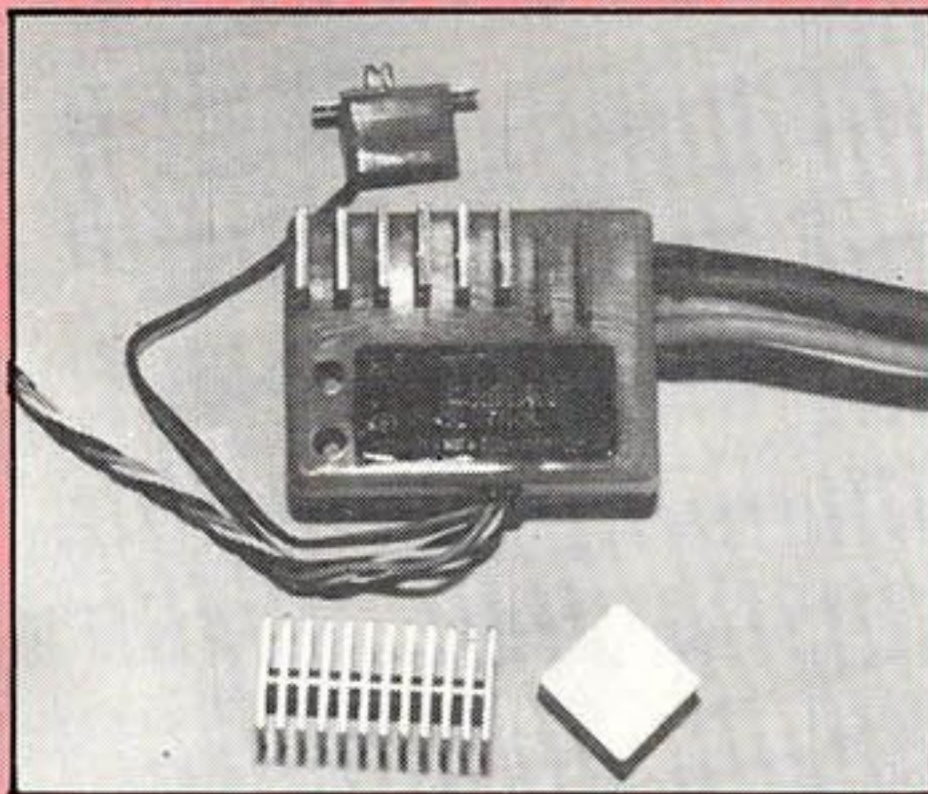

**Something Completely Different**

Among many new items released by Ripmax during the World Champs week was the new Kyosho Burns, 4wd, 1/8 off road car. Beautifully styled and looking every inch a winner, the Kyosho Burns has some interesting features. Firstly the chassis is a folded one piece metal type, this excludes the top plate and allows access to all radio and mechanical fittings. Two identical differentials are used front and rear, this cuts down expenditure on spares. Also a very clever and completely weatherproof clear inspection plate is built into each gearbox so a check can always be kept on wear rate.

At the other end of the scale Kyosho had their 1/20 scale indoor off roaders on show for the first time. These cars are half size copies of Kyosho's successful 1/10 range and are just as much fun to race. Also available for this range is ready made track marker boards and an audio visual ready, get set, go system that is completely automatic.

Both these items available soon from your nearest Ripmax stockist.

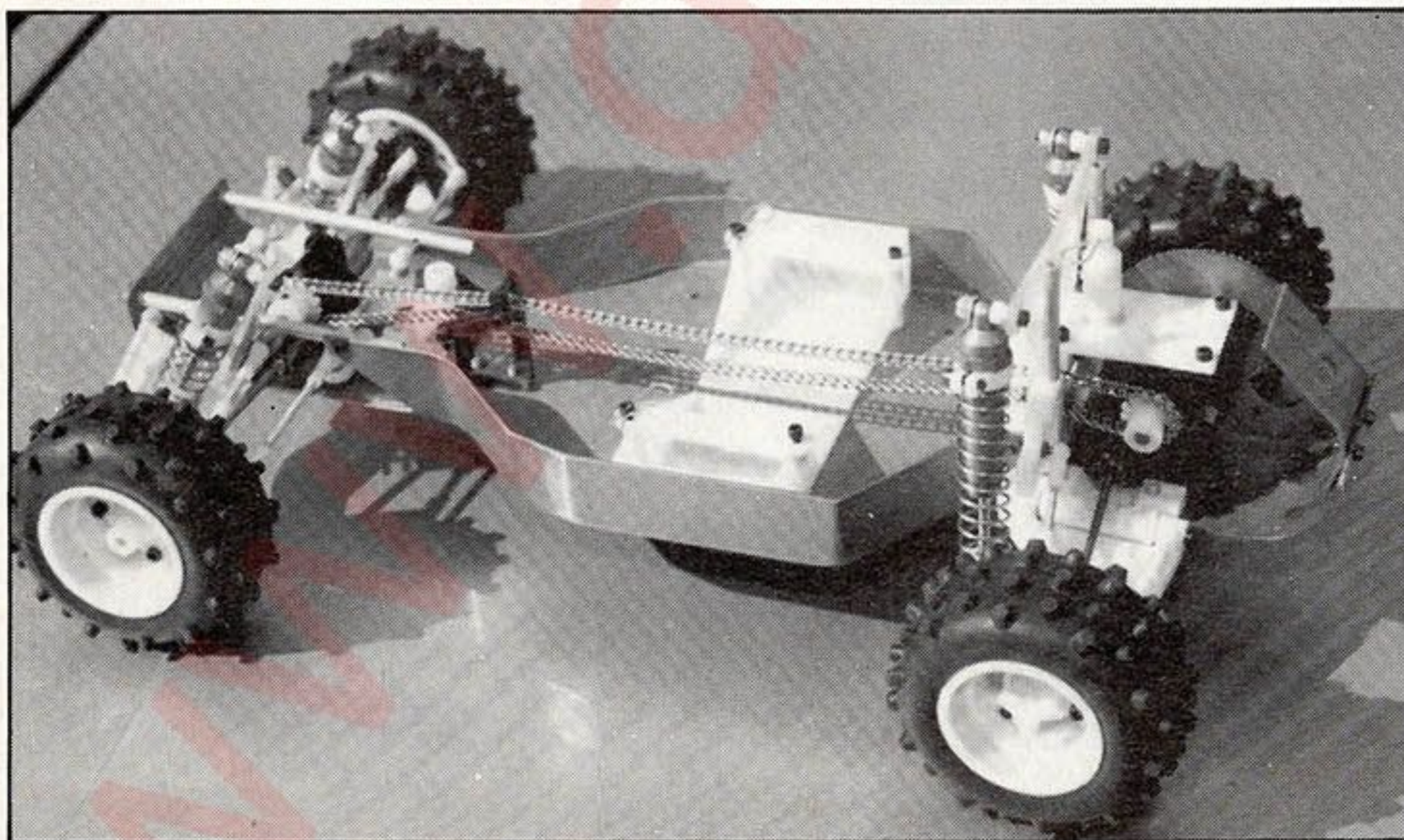

**Cobonic ECT 1 Timer**

An ideal battery operated electronic timer that incorporates a stop watch, a count down/count up facility, alarm and last but not least a clock. The timer has a memory and does not need to be reset continually, this function is automatic. The timer can be attached to anything using its built in multi purpose clip.

Available only through Cobonic Ltd (A Spirig Company), 32 Ludlow Road, Guildford, Surrey, GU2 5NW. Special introductory price £14.00.

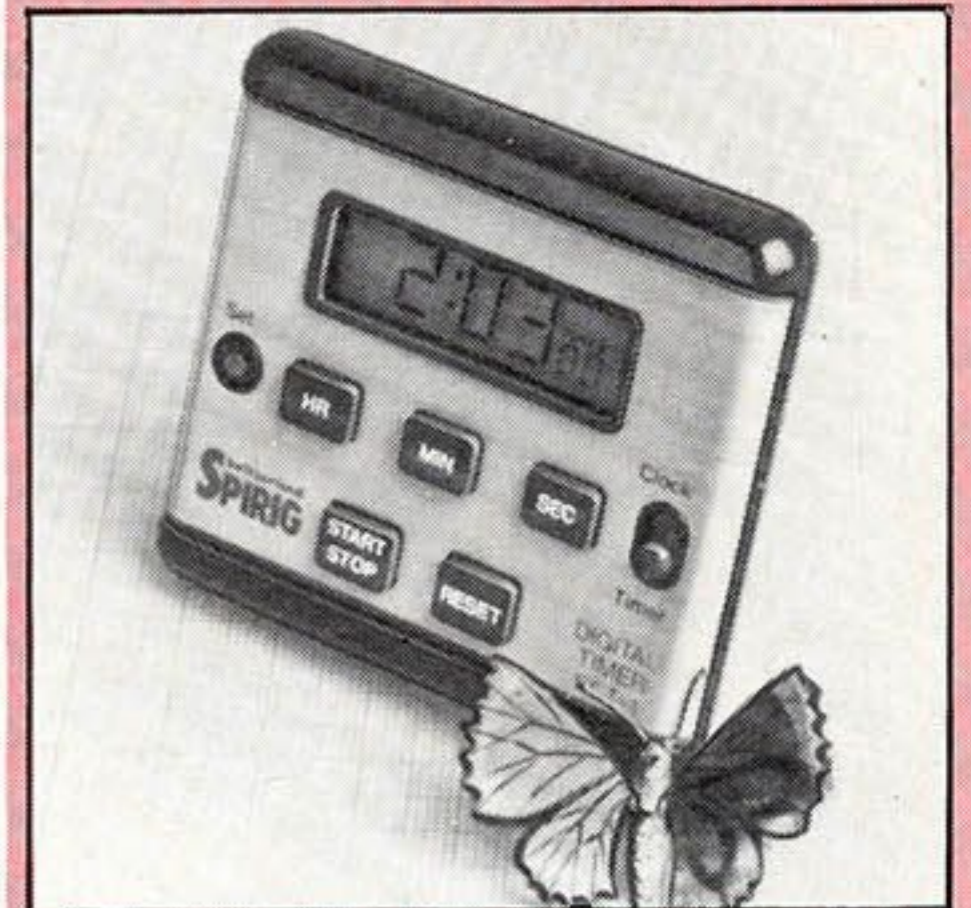

**M.I.P. RC-10**

Another item from the World Champs, the M.I.P. RC10 4wd. Using the best from all worlds Eustace Moore has produced this fabulous 4wd conversion of this excellent car. Using chain drive to the front wheels the car is strong, efficient and easy to work on. One final note it also gained a fine place for Eustace in the B final at Romsey.

Available in the U.K. from S.R.M. Racing, 140 West Street, Fareham, Hants. Tel: 0329 234262.

**Parma Products**

We couldn't have a world champs Market Place without mentioning Parma, the event sponsors now could we. Three new items this month firstly suspension clip balls for a car that is once again finding popularity the Optima and the Turbo Optima, these balls are replacements for the standard upper suspension links always a source of problems. Now there's no excuse for popping ball joints halfway through a race.

Teflon sealed precision ball bearings for the RC-10 next, these RC-10 output shaft bearings reduce friction helping the car to run smoother, faster, longer. The Teflon seal also protects the bearings from dirt and mud.

Finally from parma the Shark a new lexan bodyshell that is made as a direct replacement for the Grasshopper and the Hornet.

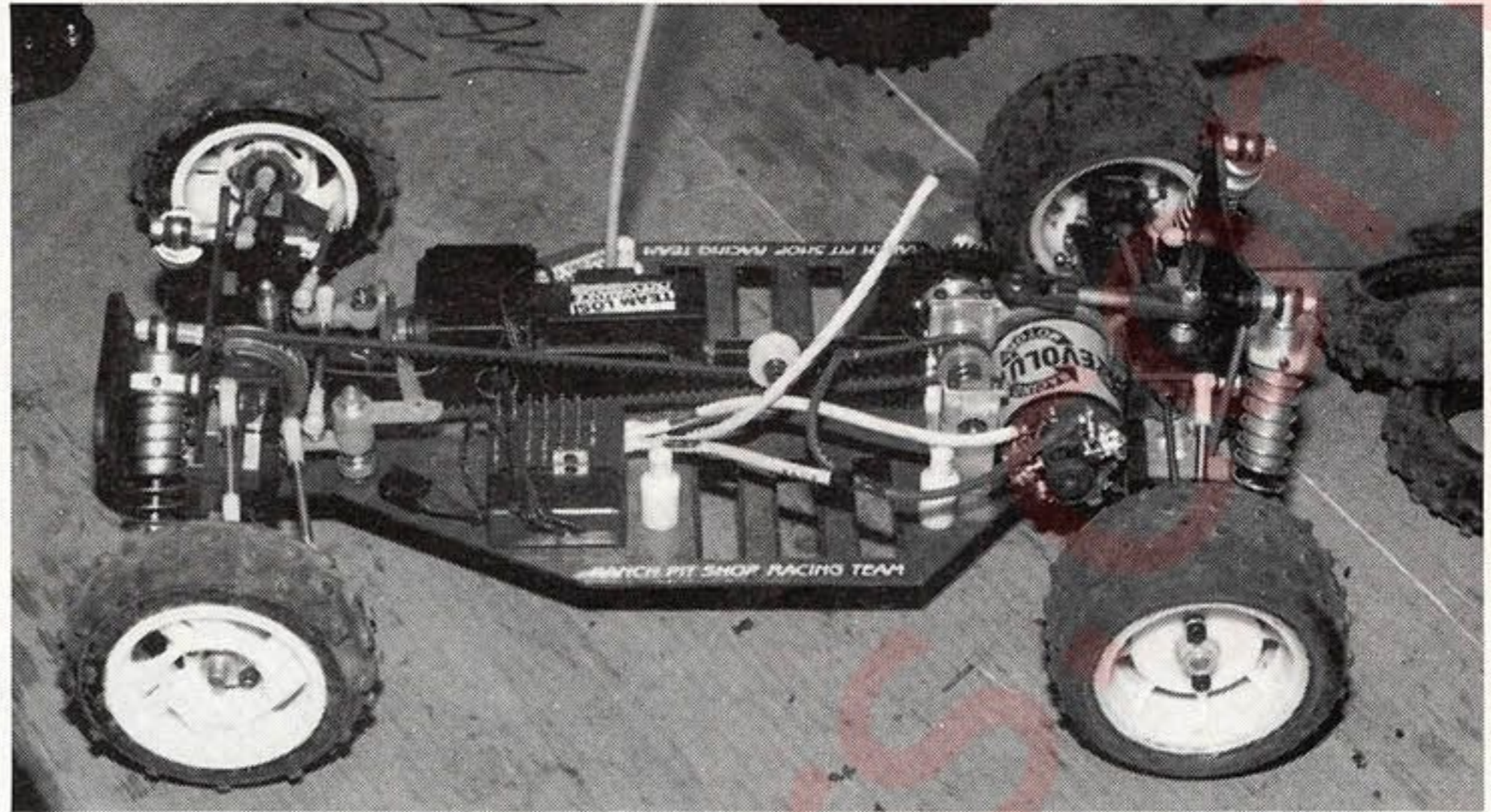

**The New Yokomo What?**

Well that's the problem you see, the new 4wd Yokomo is so new it hasn't even got a name yet. Judging by its magnificent A final appearance at the World Champs the new Yokomo will prove deadly when development is finally over. The other big plus point is the simplicity of the mechanics. For the serious racer the week

long strip down and re-build could soon be over, the transmission and differentials are so accessible and so is the belt should it break. Good news, plans are already afoot by one distributor to import the car into the U.K., the first batch they tell us should be here in early November. Just in time for Christmas.

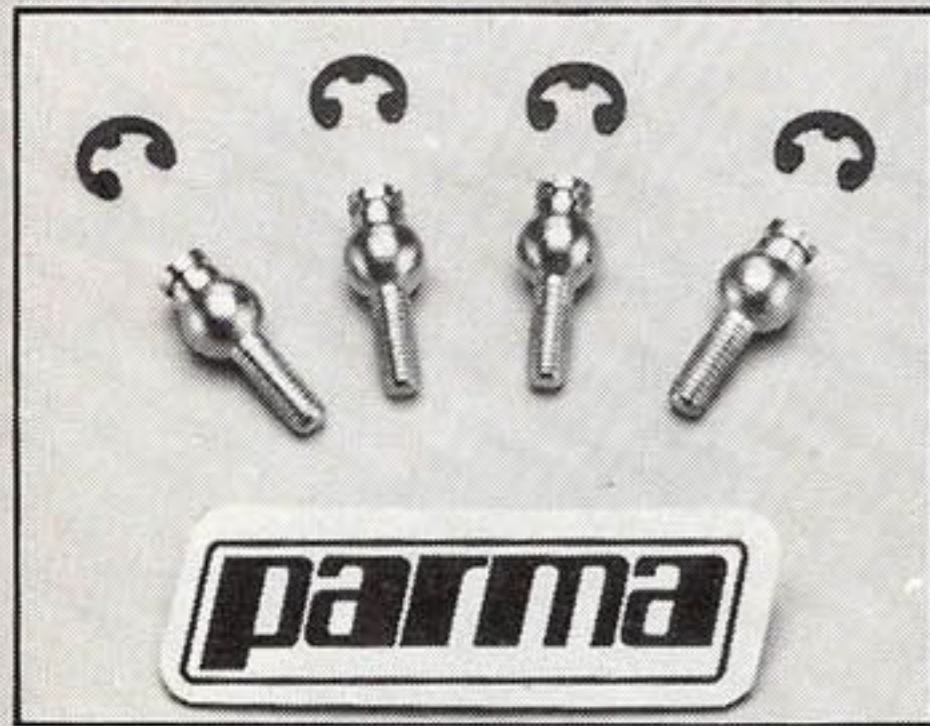
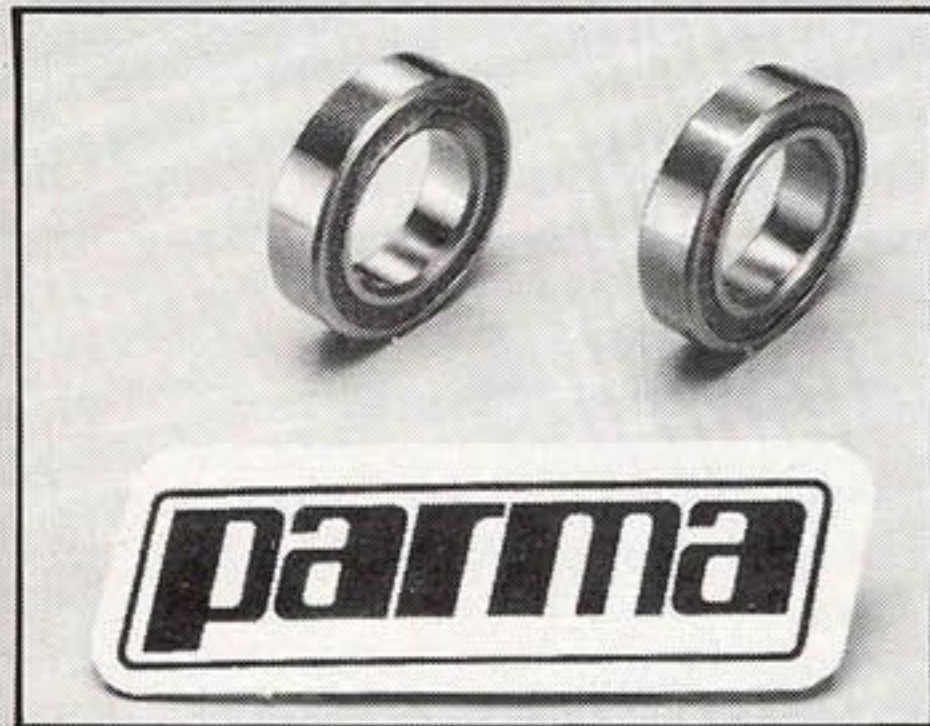

**Peelers**

Peelers a company name that carries a message, the peelers range of stickers are most impressive and are of the highest quality. There are ten sheets in the range, our photographs show only one half of one sheet! Knights in armour, flames, tiger stripes, racing decals, all these topics and many more are covered by this exciting range of new decals.

For further information contact:- Peelers, No.6, 26-28 Market Place, Blandford, Dorset. DT11 7DB, or your nearest Peeler stockist.

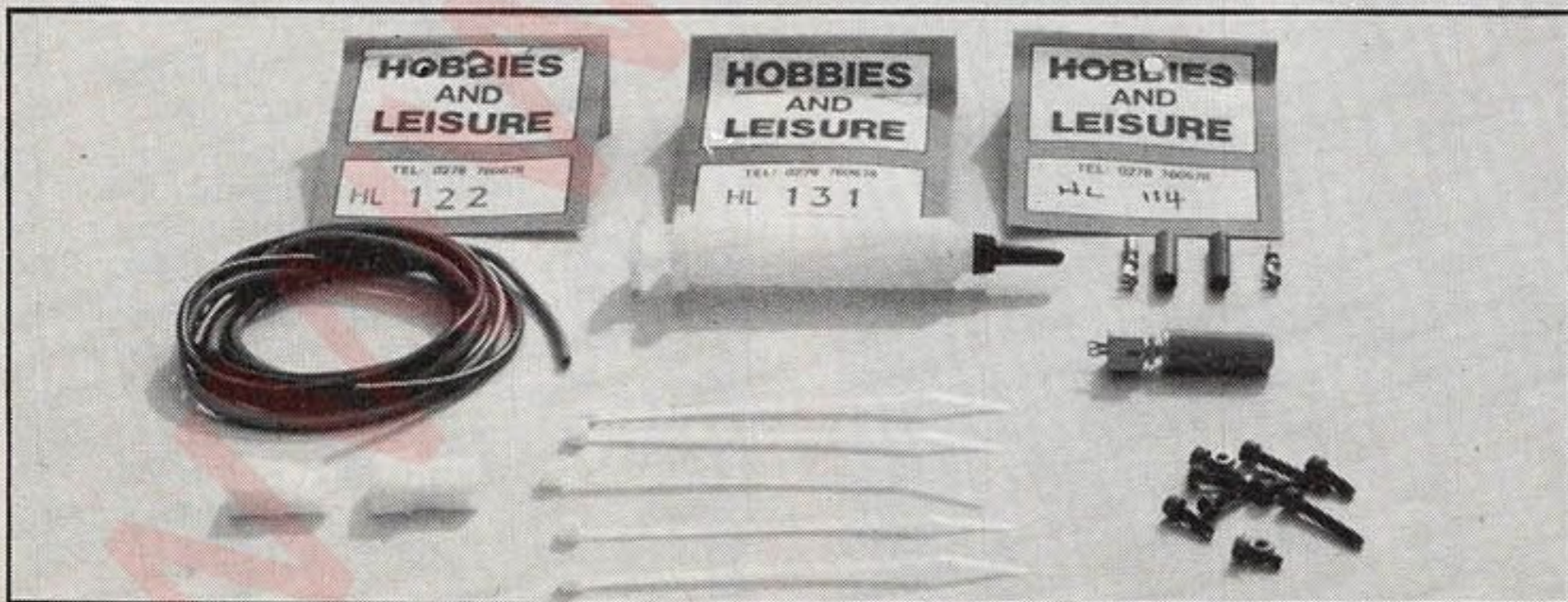

**Last But Not Least**

A new company, Hobbies and Leisure have a whole range of pre-bagged bits and pieces aimed directly at the race car driver. Pictured here is just a small selection from the Hobbies and Leisure range. A great deal of thought has gone into the selection of items for the serious racer and not one product is useless or included purely for cosmetic reasons.

For further details of Hobbies and Leisure's full range write to:- Hobbies and Leisure, High Barn, Brent Street, Brent Knoll, Somerset, TA9 4DT.



**GALAXY MODELS**

88 CATTON GROVE ROAD  
NORWICH NR3 3AA  
TEL: 0603 419515

**TOUCHTRONICS**

SUPERB ELECTRONIC SPEED CONTROLLERS

NEW

- VF5 — Forward only or forward/reverse 5 FET with proportional brake and reverse inhibit. Ideal club controller ..... £49.95
- VFR — A powerful forward/reverse 5 FET for club and competition use. Reverse inhibit with transistor brake/reverse ..... £75.00
- VF6 — FORWARD ONLY 6 FET CONTROLLER Transistor brake — club/competition use ..... £75.00
- VF8 — 8 FET FORWARD ONLY. The ultimate experts speed controller with minimum power loss ..... £85.00

RACE PROVEN — RACE WINNING — HIGH QUALITY  
BE A WINNER WITH TOUCHTRONICS  
SPEED CONTROLLERS



**HIGH QUALITY UPRATE ACCESSORIES**

BD 'S' TYPE SHOCK ABSORBERS with VVC  
10 x 14 : 10 x 20 or 10 x 30 ..... £22.50 pair

**MINI MUSTANG UNIVERSAL DRIVE SHAFTS**

one piece front shafts — give more steering angle  
£30.00

Send SAE for copy of lists and full details

**SANYO** NICADS

- 7.2v Std. Racing Pack with Plug ... £16.95
  - 7.2v Selected SCR's ..... £24.95
  - 7.2v M.I.H. Pushed SC's ..... £30.00
  - 7.2v Tamiya Racing Pack with plug....£22.95
  - 1 metre 7.2 Batt. size heat shrink ... £1.50
- STOP Now Available the Fantastic SANYO  
PRESS C.K.M.I.H. Pushed SCR's ONLY £30.00



TWO NEW CHARGERS to give the maximum to your Nicads

**DELTA PEAK** — Detects the voltage peak and automatically cuts off ..... £29.95

**THERMAL** — Complete with an external probe to monitor the temperature rise of Nicads. Cuts at approx. 37°C ..... £29.95

**ALSO AVAILABLE**

- Auto cut off chargers ..... £16.95
- Pulse Auto Cut Off ..... £19.95
- Nicad Cycler (R/C unit) ..... £14.95
- 7.2v Plugs/Sockets ..... £1.80
- 7.2v Plug or Socket (without wires) ..... 40p



**MOTORS**

- Demon 27T single ..... £11.95
- Parma Pink ..... £11.95
- Trinity Turbo Blast ..... £27.95
- Demon 22 Double ..... £24.95
- Demon 20 Double ..... £24.95
- Kyosho 480T ..... £25.00
- Kyosho Gold ..... £39.95
- Parma Enduro ..... £39.95
- Parma Sprint ..... £39.95
- Trinity Enduro ..... £39.95
- Trinity Sprint ..... £39.95

**MAIL ORDER**

Send Cheque, Money Order or Cash to: Dept. AP, or telephone your Access, Visa or American Express Number. Goods normally despatched the same day — any delay will be immediately notified. Orders over £15.00 post free otherwise please add 75p

**SHREWSBURY MODEL CENTRE**

32 St Johns Hill, 15 Mardol Gardens  
Shrewsbury Shrewsbury

Tel: 0743 245539 (both shops)

*Buggies Galore!*

2,000 sq. ft of models in our two large model shops

Typical Deal: Tamiya Hornet, 2ch Radio 7.2 Nicad, mains slow charger — £106.00

Ring or wrote for current lists on buggy deals and tune up parts

**EXPERT ADVICE — FULL REPAIR SERVICE**

Open 6 Days 9-5.30 Mon - Sat  
Late Night Fri to 7pm

MAIL ORDER WELCOME SAME DAY DESPATCH

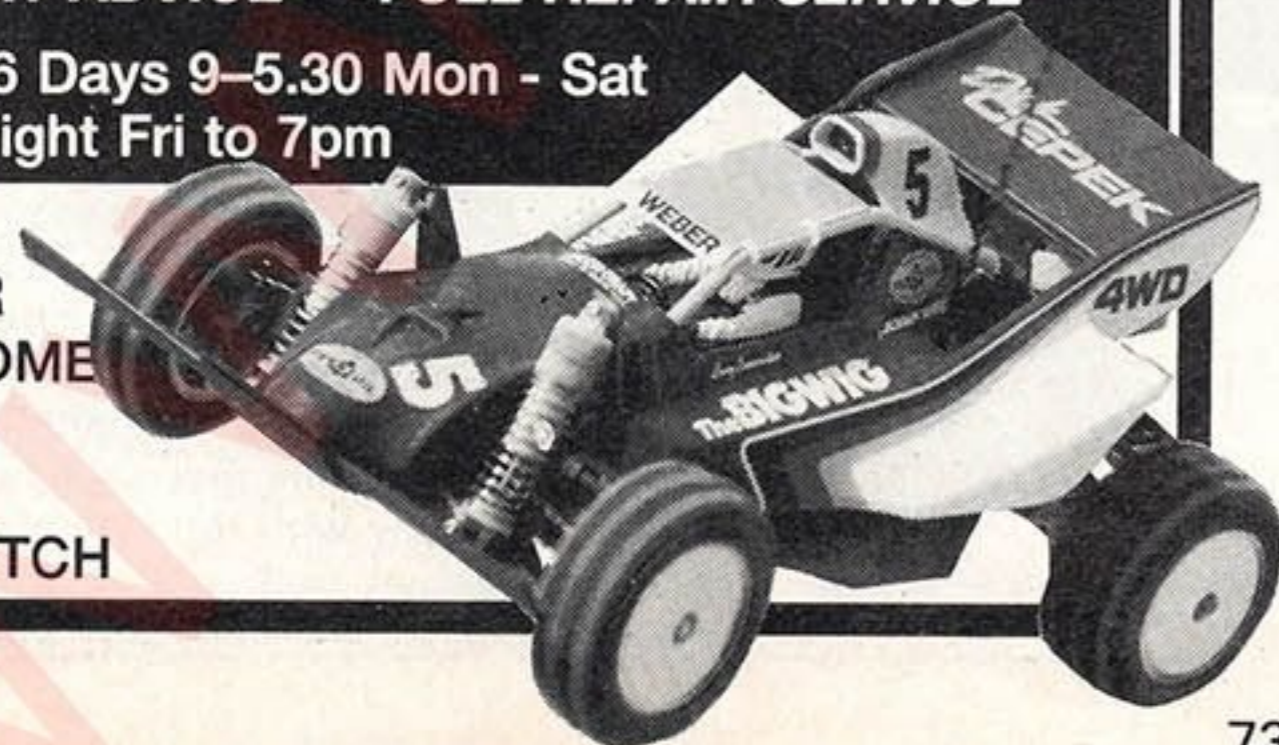

**Cheltenham Model Centre**

39 HIGH STREET, CHELTENHAM

**TAMIYA DEALS**

- New Monster Beetle — Complete Deal ..... £155.00
- New Striker — Complete Deal ..... £119.00
- Grasshopper — Complete Deal ..... £103.10
- The Hornet — Complete Deal ..... £112.70
- Falcon — Complete Deal ..... £129.95
- Blackfoot — Complete Deal ..... £149.95
- Boomerang 4WD — Complete Deal ..... £149.95
- Porsche — Complete Deal ..... £235.00

WE WILL ALSO MATCH ANY ADVERTISED PRICES ON TAMIYA KITS AND PACKAGE DEALS IN THIS MAGAZINE, IF POSSIBLE. PLEASE PHONE FOR DETAILS

Acoms quick charger (6v) £19.95, (7.2v) £21.50 post free

Post & Packing and Insurance on Kits and Complete Package Deals now Post Free

Export Sales Welcome V.A.T. Free Postage at Cost

Please send to either address:

**CHELTENHAM MODEL CENTRE**  
39 HIGH STREET CHELTENHAM  
Tel: 0242 523117 OR 0242 34644

**COTSWOLD MODELS LTD.**  
6 MARKET PARADE GLOUCESTER  
Tel: 0452 419533



**Credit Cards Welcome**

Instant Credit is available on the CMC Credit Card scheme and to most customers with current Banker or Credit Card accounts. Details available. APR 29.8% = 2.2% per month

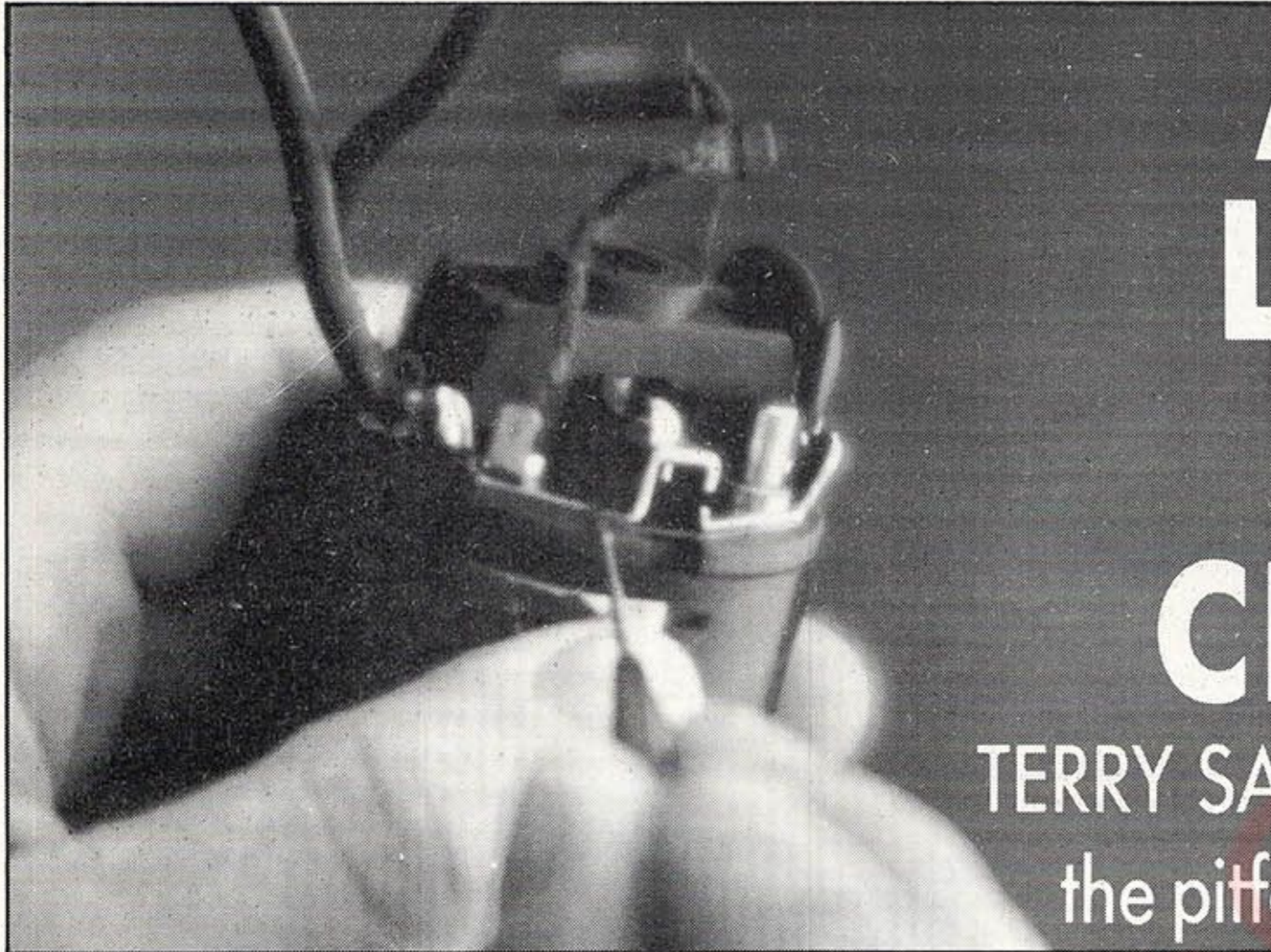

# AN AIRY LOOK AT MOTOR CLEANERS

TERRY SADLER looks at some of the pitfalls of motor additives

Go to any model car race meeting and have a good look around the pits. What do you see drivers doing in between races and burning themselves on roasting nicads. There they are all prodding away inside partially dismembered motors with cotton buds aided by blasts of spray from various aerosol containers. Yes, full marks — they are cleaning their motors — and so do you, or if you don't you should, but how and what with. What is that black gunge? Carbon brush smear. So what is the best way of removing it?

Turning back to our drivers in the pits, what are they using? Usually the range of products are basically aerosol degreasing sprays sold through model shops but originally intended for the industrial markets.

## Dad! My Fingers Have Gone All White!

For the chemically minded the contents of these sprays are mostly chlorinated and chloro-fluorinated derivatives of methane, ethane and ethylene. Not words to be said after a couple of pints! and certainly not the sort of stuff to splash on you or your car without knowing a bit more about them.

They are solvents for grease and oil and can remove the natural skin defenses, oils

*Care must always be taken when probing inside any motor, one false move and say goodbye to £40.00.*

etc., which is why when they contact your skin they leave your fingers white and dry looking. Cases of skin dermatitis and other more serious skin complaints can have their roots here. Additionally the effect on plastics, resins and light metals such as aluminium by such solvents varies tremendously.

## What's In It? Dunno Mate But Everybody Uses It

These solvents are marketed to industry for specialised applications and with advice on use. This is where some drivers can come very unstuck by using a chemical that neither he nor some suppliers know much about other than "everybody uses it"! The most commonly seen UK produced sprays state in their catalogues that some of the chemicals are hazardous but do you know which?

The "potency" of solvents is judged by a factor known as the 'KB' value — the higher this figure the more potent the solvent. The chemicals to avoid in sprays are Methylene

Chloride with a KB of 136 which will dissolve a wide range of plastics, rubbers and resins and will react with aluminium and Trichloroethylene with a KB of 130. Trichloroethane with a KB of 124 is also to be avoided unless you are very careful of conditions of use and minimise any contact with polycarbonate (Lexan). The former two chemicals are considered the most toxic of the range and are excellent solvents for all sorts of bits of a model car. The best advice is if you don't know what it is and cannot obtain clear advice then don't use it. Above all limit skin contact with any chemical to an absolute minimum and don't inhale while spraying. I know you've been doing it for years with no problems — a lot of smokers said that — get the picture?

## So What Do I Use?

The answer is simple as there are now sprays that are safe to use, will not attack you or any of the plastic or other parts of your car and will remove motor brush smear, greasy deposits and will even remove that dreadful adhesive on racing numbers without affecting the lexan body. These products are specifically packaged for the model racer are backed with a range of cleaning accessories to keep motors and cars in top condition with no risk to you or your model.

It is still important to understand what you are doing when using an aerosol product. Always work under conditions of good ventilation and spray away from you. When fitting spray heads keep the spray pointing away from you. Minimise skin contact by putting your hand in a plastic bag before spraying anything when spray is likely to go over your fingers. High pressure sprays will drive solvents into your skin — don't risk your health.

## Clean Ears

The good old cotton bud is all that is currently available for moving the stubborn crud on commutators and judging by the state of the pits after a meeting the local chemists must think there is a competition on for the baby with the cleanest ears!

The problem with cotton buds is that they shed little bits of cotton wool and this

*Foam buds will fit directly against the comm. and leave no cotton.*

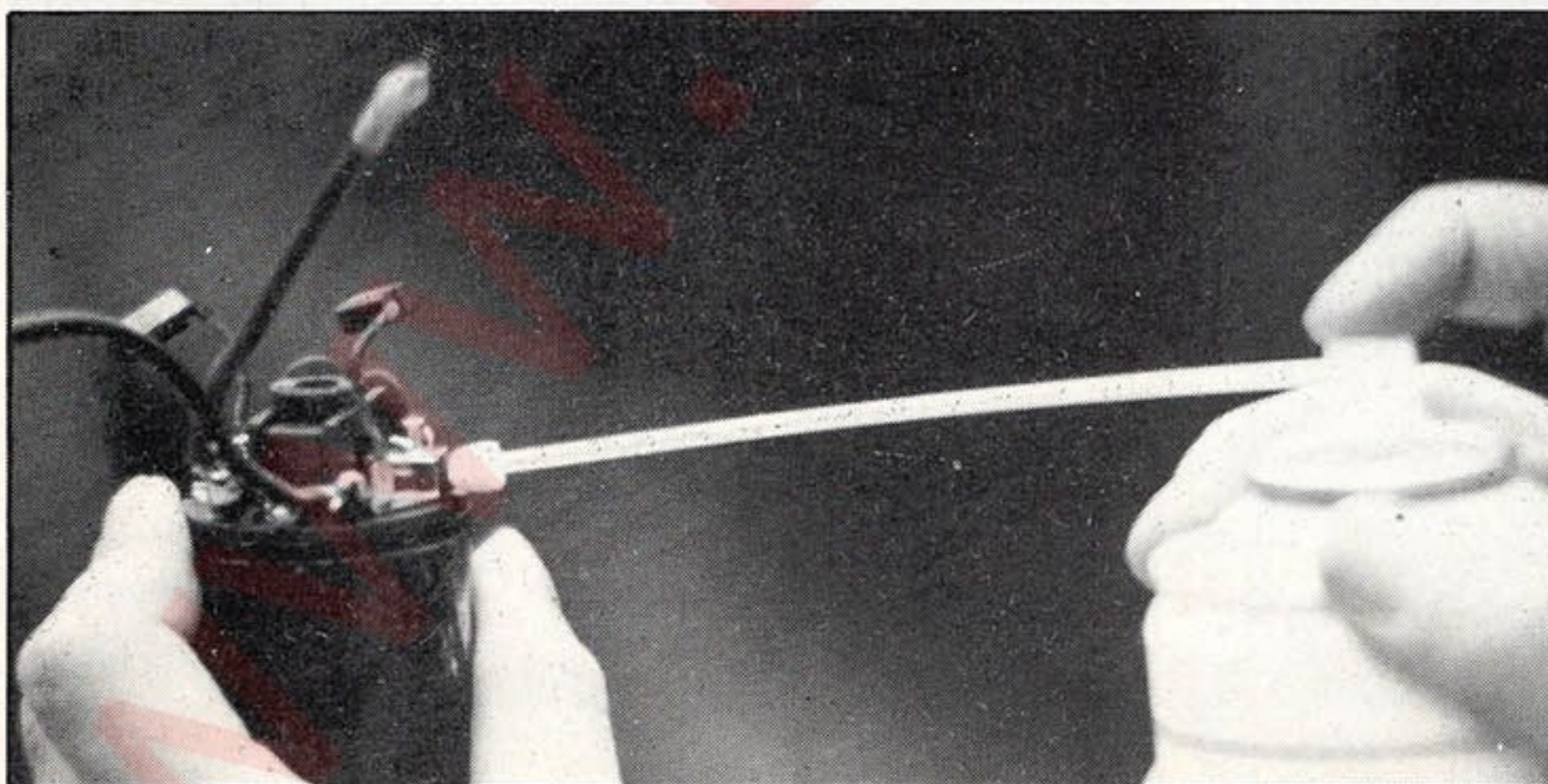

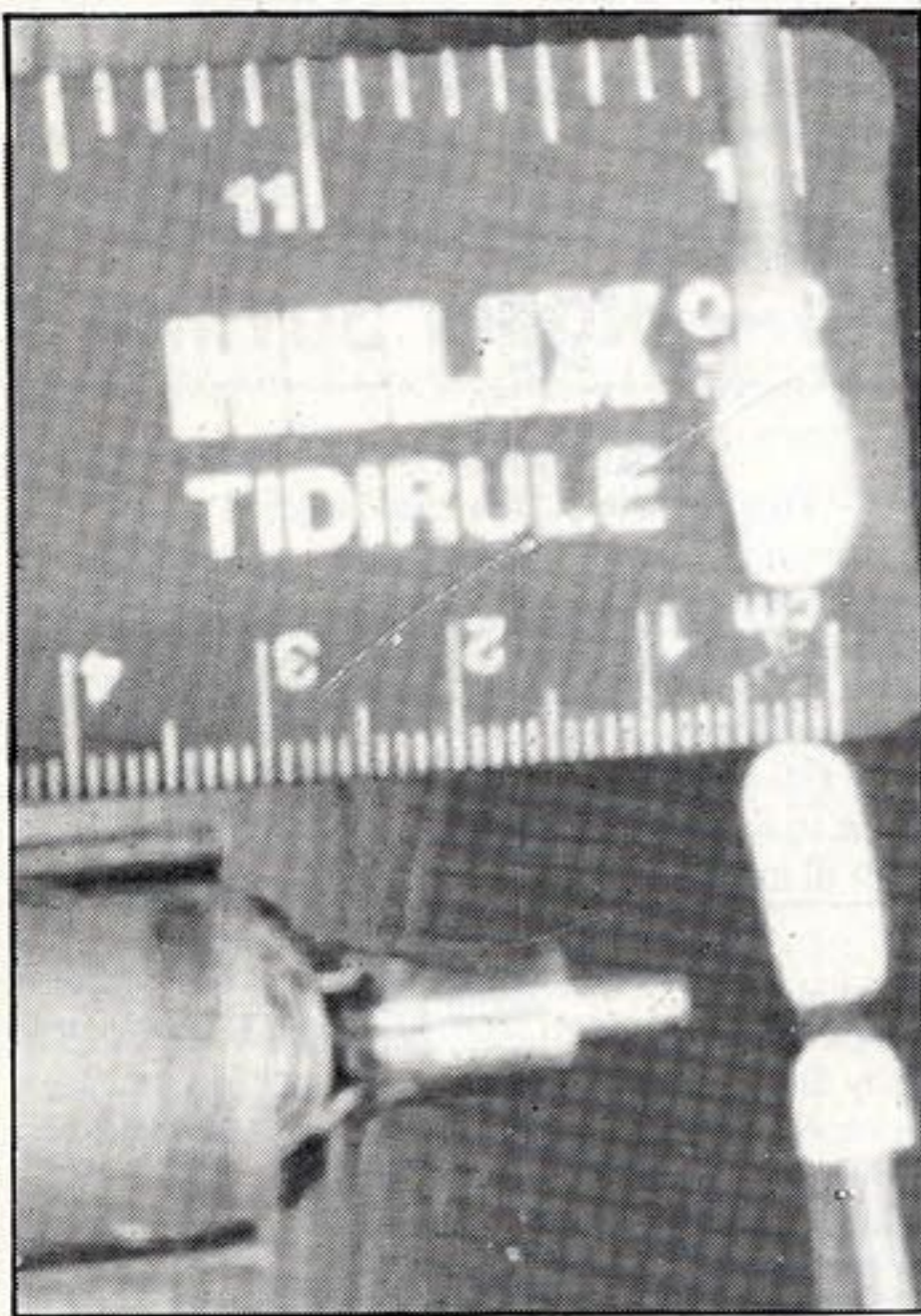

gets caught up in the motors, around the commutator, and on any sharp protruding bits and can jam brushes or build up around the armature, collecting oil, bits of grass and other debris. There is an alternative to the bud in the shape of new 'Foambuds' which as their name suggests are a bud made of foam. So what you say? Well listen to this. The foambuds are made of pure grade polyurethane foam and will not crack, or shed any particles inside your motor. Apart from this they actually fit into the brush holders without a shoe-horn. Now this is the good bit — the foamtips have a unique three-dimensional cellular structure which provides a deep maze enhancing not only the ability to hold cleaning fluid longer but also to provide lots of area for particle entrapment to prevent spreading muck around. As an additional bonus, Foambuds are fitted to tubes just like those used for aerosol extensions. You can now feed products such as Motor \*1 on to the bud while it is in the motor and even blast off any soil from the bud with another squirt before cleaning again — very economical. How about that.

**Shifting The Carbon**

You have paid a lot of money for your motor, so do take care of it. Modified motors are easy to clean since they can be

taken apart. While removing the carbon from the surface of the commutator don't forget to clean out between the copper segments. Carbon and copper dust can build up here and short the segments. Take a piece of copper wire about 1mm dia., and flatten the end. Use this to rake out the segment gap but be very careful not to damage the insulator at the base of each slot. Spray will soften the carbon and aid this operation. The use of motor additives will mean more carbon build up in these slots.

Standard class motors are more difficult to clean. The use of a spray to wash the commutator and bearing area (both ends) followed by solvent wetted buds to remove softened carbon is the accepted method. With care the commutator slots can be cleaned as already described but this time poking the tool down alongside the brush holder — very fiddly.

Don't forget to hose off all the dust around the magnets and bearings. With the standard motors use the holes in the ends and wash muck away from the commutator end until the fluid leaving the motor is clear. After cleaning lubricate bearings with a non-silicone oil.

**Keeping The Wheels Turning**

So now you've cleaned the motor without melting anything or anybody but there are still some points to clear up concerning additives etc.

Does anybody know what silica is? Good that man at the back-you are correct, silica is the basic element of glass. Now take a spray containing silicone and spray it near your mechanical speed control or motor. What do you get when you thrust the stick forwards — yes a spark at the brushes and at the wiper on the control. This spark is very hot (which is why mechanical speed controls burn out) and when silicone is heated, a glass-like material is formed-right on the contact. Don't say it doesn't happen because lots of people scrub away at their speed control to get off those "little places where it doesn't work" and our very own privatised telecommunication company suffers terribly with this problem in exchanges and has banned even floor polishes containing silicone. So don't whatever you do ever use silicone sprays on contacts or in servos (ruins the pots) and the same applies to silicone grease as the action of silicone is to creep over everything, which is why it's so good at chasing water off real car electricians.

There are contact lubricants which re-

duce sparking on mechanical speed controls (makes 'em last much longer) which is non-flammable and equally suitable for lubricating brushes in motors and wheel bearings. They are synthetic non-silicon, non-hydrocarbon, non-fractionating lubricants which will not stain and are perfect for lubricating everything in the car including the pots in transmitters and the contacts on those horrible battery boxes. Dead clever stuff eh!

**Anyone For Additives**

What about additives? There are so called go-faster sprays that are designed to be added to the motor just before the start of a race. All these do is to soften the brushes allowing a slightly improved surface contact while forming a lubricant of softened carbon. The effect is noticeable but only for as long as the chemical (usually one of the more aggressive solvents) lasts which is generally not long due to the high evaporation rate.

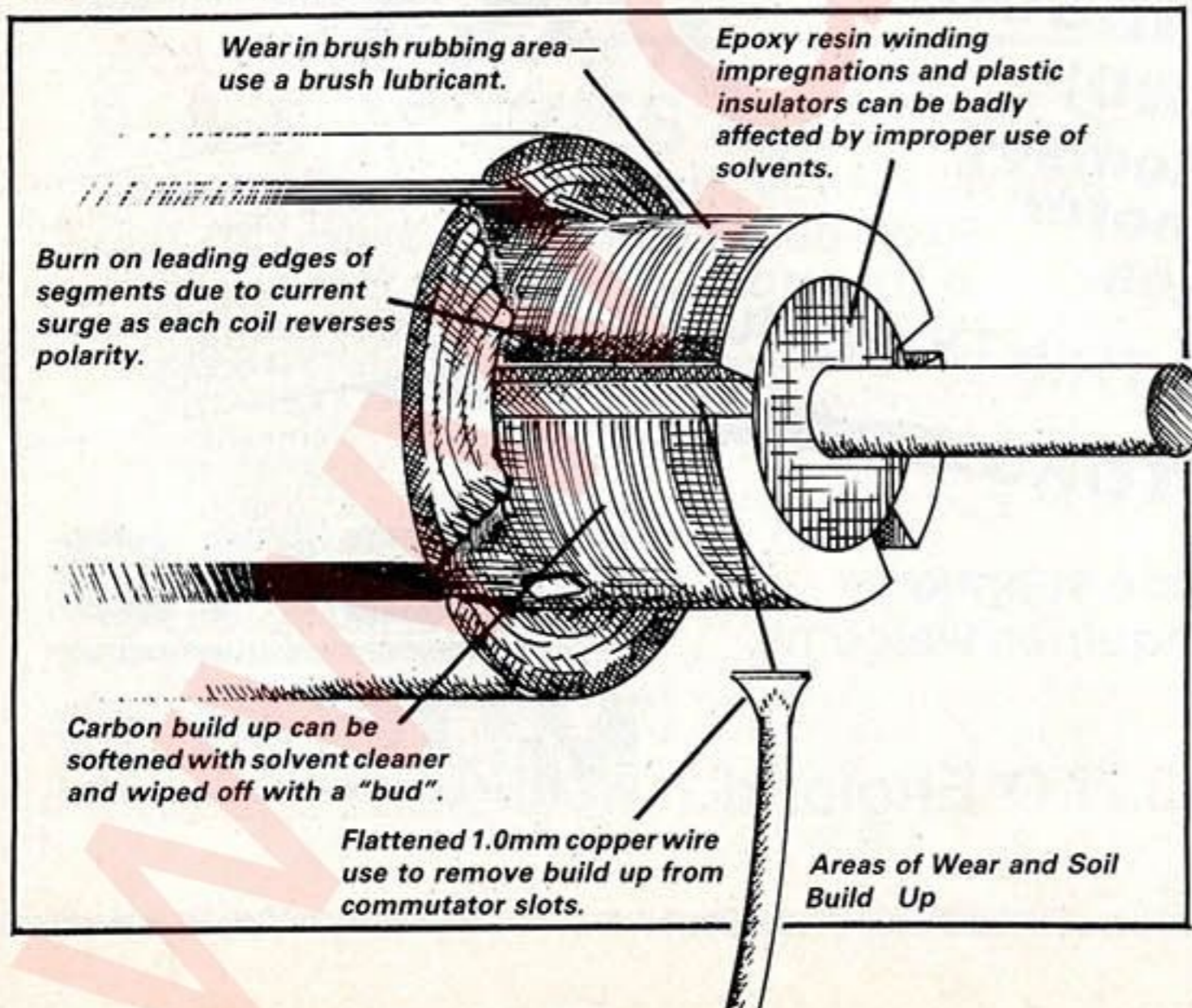

Don't forget to gently remove gunge from the channel between the comm. segments as shorting can take place here.

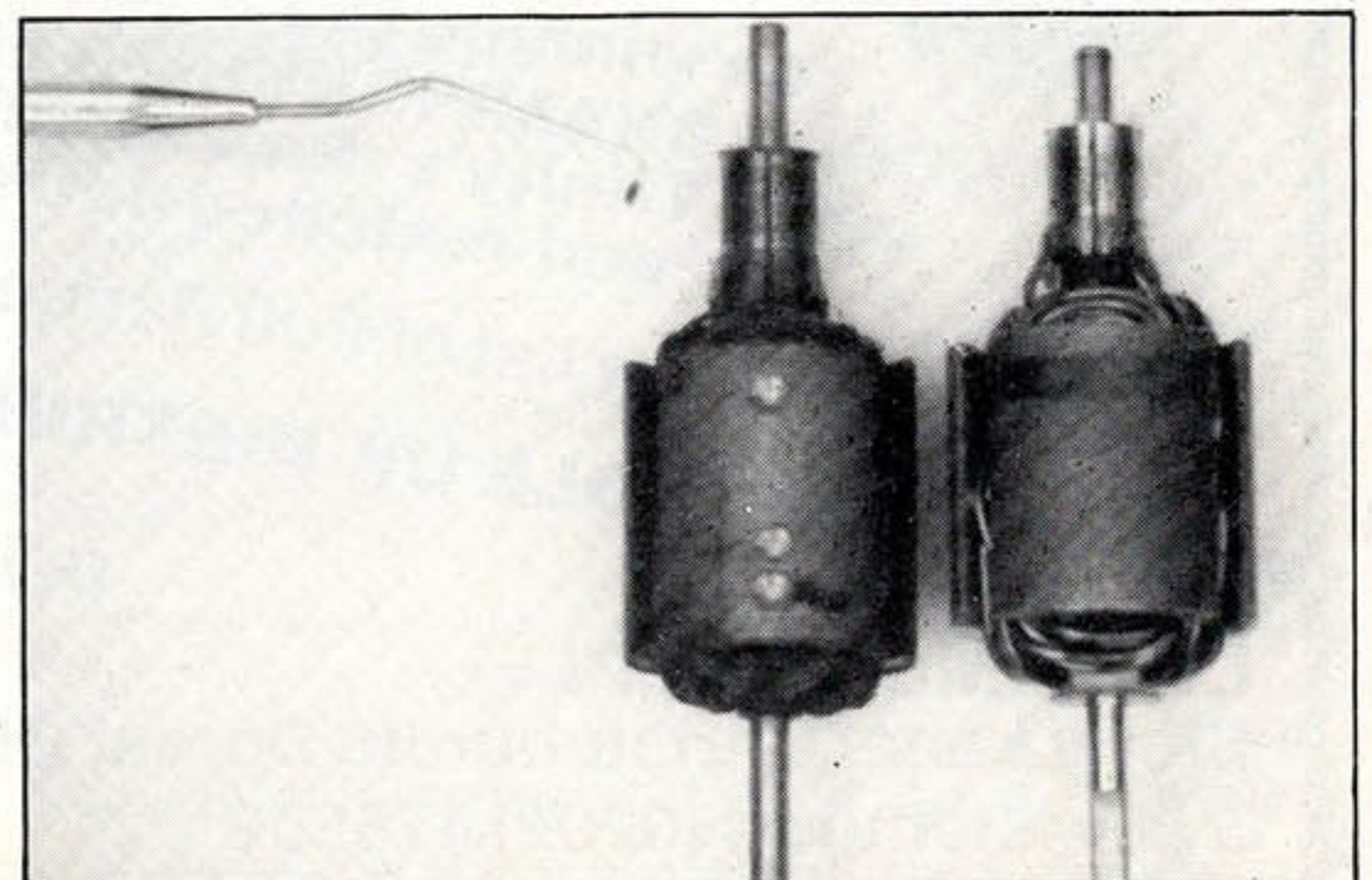

# OTLEY Modelsport

2 CROSS GREEN, OTLEY, W. YORKS. LS21 1HD  
 TEL: 0943-466535  
 OPEN MON-SAT  
 9.00am-5.30pm

**Moving with the Times! Bigger Shop — Bigger Stocks — Bigger Savings!**

TAMIYA	KIT	+DEAL 60	+DEAL 66
New! Lunchbox	£69.00	£109.00	£115.00
Grasshopper	£44.00	£104.00	£110.00
Hornet	£54.00	£114.00	£120.00
Striker	£54.00	£114.00	£120.00
Falcon	£64.00	£124.00	£130.00
Blackfoot	£84.00	£144.00	£150.00
Monster			
Beetle	£87.00	£147.00	£153.00
Boomerang	£89.00	£149.00	£155.00
New! Hotshot II	£109.00	£169.00	£175.00
Porsche 959	£139.00	—	£205.00
Bigwig	£144.00	—	£210.00

KYOSHO			
Ultima	£94.00	£154.00	£160.00
Rocky	£94.00	£154.00	£160.00
New! Rocky Turbo	£124.00	£184.00	£190.00
Optima	£109.00	£169.00	£175.00
Salute	£169.00	£229.00	£235.00
Turbo Optima	£179.00	£239.00	£245.00

MARUI			
Big Bear	£64.00	£130.00	£135.00
Ninja	£89.00	£149.00	£155.00

MARDAVE			
Meteor (Comp.)	£53.00	£113.00	£119.00
Meteor (Std)	£55.00	£115.00	£121.00

Schumacher Cat	P.O.A.
Mini Mustang	P.O.A.
Yankee Electra	£185.00
Raco Jac-Rabbit	£895.00

NICADS	
Sanyo Yellowsticks 7.2v	£16.95
Sanyo SCR Redsticks 7.2v	£18.95
Schumacher Custom SCR's	£22.50
MIH Pushed 7.2v SC's	£29.95
MIH Pushed 7.2v SCR's	£39.00
Parma Selected 7.2v	£19.95
Tamiya Racing Pack 7.2v	£18.95
Tamiya 8.4v Goldpower	£27.95
'AA' Size Pencells	ea 95p

\*\*\*\*\*  
**DEAL 60**  
 \* Comprising Acoms Techniplus R/C 7.2v Saft Nicad, &  
 \* either Mains Slow Charger or Parma 12v Fast Charger

**All for only £60.00**

\*\*\*\*\*  
**DEAL 66**  
 \* Comprising Futaba Attack BEC R/C 7.2v Sanyo Yel-  
 \* lowstick or Tamiya Racing Pack Nicad & either Mains  
 \* Slow Charger or Parma 12v Fast Charger

**All for only £66.00**

**INSTANT MAIL ORDER**



**SAME DAY SERVICE**

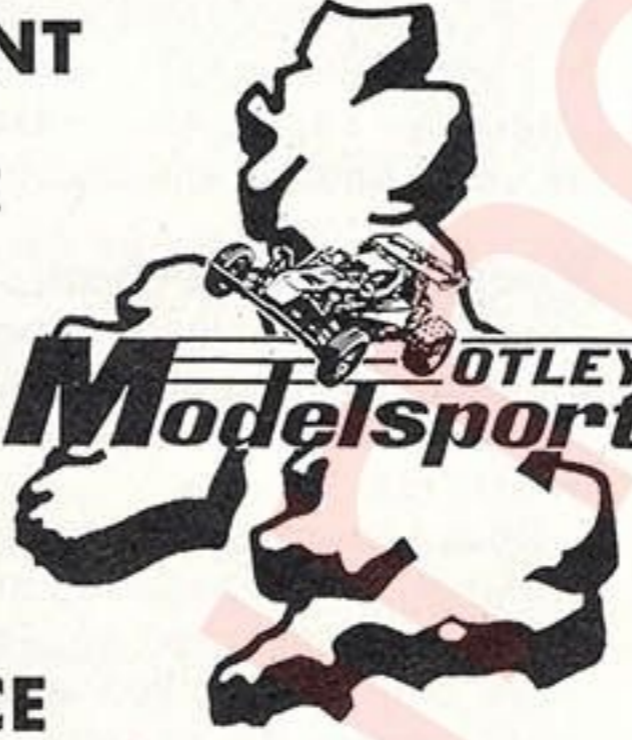

BALL RACE SETS	
Top Quality Double Shielded	
Boomerang (17 lge/5 sm)	£27.00
Falcon (11 lge/1 sm)	£15.00
Hornet (9 lge/1 sm)	£13.50
Striker (11 lge/1 sm)	£15.00
Optima (10 lge/2 sm)	£19.00
Rocky (12 lge/2 sm)	£22.00
Ultima (6 lge/6 sm/2 ex.lge.)	£23.50
Ninja (8 lge/14 sm)	£35.00

MOTORS	
Scorcher, Spirit 600, Yokomo	£11.95
Demon 27T, Parma K.	£11.95
Trinity Stock	£14.95
Parma Modifieds	£39.95
(Enduro, Sprint, Super Sprint, Oval)	
Trinity Modifieds	£40.00
Sprint, Enduro, Pure Gold)	
Trinity Turbo Blast	£29.00
Tamiya Technipower	£27.00
Tamiya Technigold	£35.00

Kyosho Le Mans and Option House:			
600E	£12.95	240S	£22.50
480T	£22.50	480S	£22.50
360PT	£27.00	480 Gold	£32.00
240SB	£36.00	360 Gold	£41.00
SPA 240WS	£39.95	SPA 480WT	£39.95

ELECTRONIC SPEED CONTROLLERS	
Intronics Firefly G.T.	£42.00
Intronics International	£49.95
Nosram Advanced F.E.T.	£67.00
Laser Comfet	£69.95
J.R. F.E.T.	£50.00

**POSTAGE, PACKING & INSURANCE: £2.00 for KITS, £3.00 for DEALS, OTHER ITEMS: 75p (minimum)**

# TRINITY

**'Magic' Wins Again!**  
 Congratulations to **Joel Johnson**  
 on winning the IFMAR (2WD)  
**WORLD CHAMPIONSHIPS** at Romsey  
 using Trinity's 'Pure Gold' motor  
 and matched batteries.



Due to BRCA ruling on price limits, TRINITY RC# 2000 Standard Motors available direct from Lesro at £12 NO CREDIT CARDS

Send S.A.E. for list of Full Range of TRINITY products  
**SOLE UK DISTRIBUTORS**

Trade supplied,  
 New enquiries welcome



**Lesro Models Ltd.**  
 Stony Lane, Christchurch, Dorset BH23 7LQ England  
 Christchurch (0202) 476902

SPECIALISTS IN RADIO CONTROLLED MODELLS, KITS & ACCESSORIES

# RADIO-ACTIVE (MODELS)

Tel: Chelmsford (0245) 442164  
 100 MAIN ROAD, BROOMFIELD, CHELMSFORD, ESSEX.  
 specialist in radio controlled models, kits and accessories  
 OPEN MONDAY, TUESDAY, WEDNESDAY, THURSDAY  
 AND SATURDAY 9 a.m.-6 p.m. FRIDAY LATE NIGHT 9 a.m.-7 p.m.  
 We have plenty of normal stock, Motors, Batteries, Kits, Radio's etc. etc. but special to Radio Active CHELMSFORD, we have!!!

## ELECTRONIC SPEED CONTROLLERS

Photon	£52.95
Photon Competition Special	£59.95
Ashbourne Magnum	£49.95
Robot	£45.95
Futaba	£49.95

### CHARGERS

Thermal for Pushed and Normal Cells	£34.95
Also Thermal Charger with temperature display	£59.95
J.M.E.	£16.95
Model Flight	£16.95
Ashbourne	£17.45
Acoms	£19.95

WHY NOT PAY US A VISIT AND SEE OUR RECENTLY ENLARGED PREMISES WITH PLENTY OF STOCK AND FRIENDLY AND HELPFUL ADVICE.

Same day Mail Order  
 ACCESS & BARCLAYCARD



# Macartneys Models

83 New Road, Kidderminster  
 Tel 0562 754308

LOOK AT OUR SPECIAL SUMMER PRICES

	Car	Pack A with Slow Charger	Pack B with Timed Fast Charger
Grasshopper	39.95	96.95	106.90
Hornet	47.95	106.95	116.90
Falcon	57.95	116.95	126.90
Striker	55.95	106.95	116.90
Boomerang	79.95	139.95	149.90
Hotshot Mk.2	98.95	164.95	174.90
Vanessa Lunch Box	62.95	127.95	137.90
Monster Beetle	78.95	137.95	147.90
Big Bears	54.95	109.95	119.90
Mardave Meteor	49.95	117.95	127.90

All Deals include Futaba & Acoms BEC Radio

Ring for our Special Kyosho Prices  
 Futaba BEC Attack Radio JUST £39.95  
 (We retain the right to alter any prices)  
 Please ring for Stock Availability

Open 10am to 5.30 Monday to Saturday. Closed Wed. All Day  
 Postage: Kits £2.00. Deals £2.50 +50p insurance on both

## COLCHESTER MODEL CARS

12-15 Burlington Road, Colchester  
 Tel: 0206 563474. Evenings 0206 271937

LOOK NO FURTHER FOR YOUR BALLRACES, WE HAVE A VAST STOCK OF QUALITY BEARINGS AT HARD TO BEAT PRICES.  
 WHY PAY MORE?

e.g. Tamiya size \* Large £1.00 ea. \* Small £1.50, Kyosho size \* Large (also fits the Meteor) £1.40 ea \* Small (Flanged & unflanged) £1.65 ea. Motor Bearings £2.00 each. Output shaft for Optima and Ultima £4.50 pr. Ballraces for the CAT and Mini Stocks available, plus many others.  
 Ballrace Kits \* Boomerang £23.95 \* Ninja £30.50 \* Optima £14.95 \* Rocky £16.95 \* Meteor £8.50 etc. p&p extra.

Watch this space for details of the Nichimo Luminous arriving soon

Also large selection of models & accessories available. Mail order enquiries welcome.



ALWAYS A WINNER!



## P. & S. HOBBIES & MODELS

32 Castle Road, Scarborough Tel: 0723 - 377020  
 SCARBOROUGH'S PREMIER BUGGY SHOP  
 BRCA LEGAL STD TRINITY MOTOR £11.95

Tamiya, Mabuchi, M.G., Yokomo, Stds & Mods plus full complement of armatures brushes hard, soft, timed etc.  
 KYOSHO's latest Baby the Ultima Back IN STOCK  
 Turbo Optima's, Salute's, New Option House Drive Shafts.  
 LATEST PB SUPER MUSTANGS. THESE KITS ARE PROBABLY UNBEATABLE FOR VALUE AND PERFORMANCE. RING FOR DETAILS ON EARLIEST DELIVERY

NEW SERVICE NICAD ANALYSIS SEND NICAD & £2.00 FOR COMPLETE CHARTS SHOWING FULL & INDIVIDUAL CELL DISCHARGE  
 Telephone orders taken personally from 8am till 10pm  
 Send 50p in stamps & Large SAE for latest computer lists  
 SCOOP PURCHASE SERPENT COBRA 4WD OFF ROAD CAR BACK IN STOCK NOW INCLUDING ENGINE 2 BODYSHELLS STD & LOW PROFILE WHEELS & TYRES.  
 AMAZING VALUE AT ONLY £260.00

# Radio Race Car Binders

Keep up to 12 issues of Radio Race Car safe on the book shelf in our new luxurious and strong gold blocked binders, for only £6.25 plus 65p postage and packing in the UK.

Just photocopy or cut out this coupon, fill in and send off with cheque/PO for only £6.90 or Access/Barclaycard No. to

Radio Race Car (Binder Offer),  
 Masefield House, Wells Road,  
 Malvern, Worcestershire, WR14 4PA,  
 England.

PLEASE PRINT CLEARLY IN BLOCK CAPITALS

Name .....

Address .....

.....

Access/Barclaycard No. ....

Expiry Date .....

Signature .....

N.B. Overseas postage:  
 Europe £1.00. Worldwide £3.50  
 Airmail, £1.00 Surface.

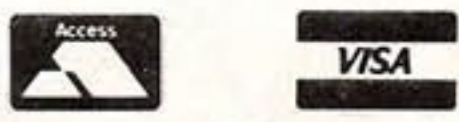
**EXCHANGE & MART**

# TAMIYA OFF ROAD CHAMPIONSHIP 1987



This year's Tamiya Championship for radio controlled off-road buggies will be held at the Three Counties Showground, Malvern, over the weekend of the 3rd/4th October 1987, in conjunction with the Malvern Motoring Event and Exchange & Mart. This venue has been chosen for the third consecutive year as the facilities are excellent for a purpose-built circuit where both track and pits are completely covered — unaffected by the weather.

*A great day out for the family*

One hundred and fifty drivers have been invited to compete, selected as the top competitors from the many qualifying rounds held during the year around the U.K. Two classes of competition — Production — for drivers who wish to use standard cars and Superdrive — for those who wish to modify their vehicles, ensure close competitive racing throughout the series.

Why not come along and view the exciting spectacle of 1/10th off-road buggy racing, together with all the attraction of the Malvern Motoring Event. Hope to see you there.



**RIKO**

13-15a High Street  
Hemel Hempstead  
Hertfordshire  
HR1 3AD

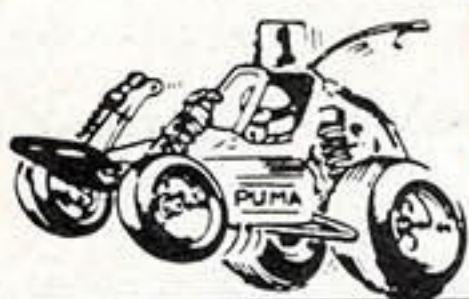

## PUMA RACING

(MODELS LTD)

R/C MODEL CAR SPECIALISTS

FULL RANGE OF SPARES ALWAYS AVAILABLE FOR CATS, MUSTANGS, METEORS, ASSOCIATED AND TAMIYA

**KITS**

Schumacher C.A.T.	£175.00
P.B. Mini Mustang 4WD S/S	£159.00
Tamiya Striker	
Tamiya Falcon	Phone
Tamiya Blackfoot	For
Tamiya Boomerang	Latest
Tamiya Big Wig	Prices
Tamiya Porsche 959	
Tamiya TamTech	
Mardave Meteor	£ 57.00
Kyosho Optima	£115.95
Kyosho Optima Turbo	£170.95
Puma International Stockcar	£ 70.75
Mardave Stockmaster	£ 54.95

FREE SCR NICAD

**RADIOS**

Futaba Attack	£54.95
Acoms Techniplus BEC	£52.95
Acoms Techniplus	£49.00

Spares and Accessories Available  
Range of Crystals In Stock

**MOTORS (All Winds)**

Full Range Le Mans From	£11.95
most accessories in stock	To £39.95
Demon	£12.00
Spirit 600	£12.00
K-Stock	£12.00
Parma Pink	£12.00
Parma Modified	£39.95

**VALUE PACKS**

- NICAD HEATSHRINK\* CONNECTORS
- VELCRO\*
- PACTRA PAINT BEARINGS\*
- GEARS
- LOSI PINION GEARS
- WHIP AERIAL KIT
- SERVO TAPE\*
- DECALS/STICKERS
- TRIFLOW\*
- BODYCLIPS
- CABLE TIES\*

**CHARGERS**

Acoms-Schumacher  
Kyosho

**BATTERIES**

SCR Selected Nicads

Car specialists with 14 years experience in R/C racing at club and international level friendly and expert advice given so come along to see us now.

**SOLE UK DISTRIBUTOR FOR TRANSAM ELECTRONIC SPEED CONTROLLER**  
Forward Fet Only £57.95  
Forward and Reverse £59.95  
Trade Enquiries Welcome

**TUNE UP GOODIES!**

PARMA SRM  
OPTION HOUSE  
PUMA PROLINE  
DYNAMITE

**NEW**  
PUMA "MINI MUSTANG" LEXAN UNDERTRAY £5.95  
PUMA "LAZER" METEOR/MINI MUSTANG BODYSHELL £9.95  
FULL RANGE OF PARMA LEXAN BODYSHELLS  
Special Custom Painting Service on Lexan Bodysells Available  
High Performance Shock Oil - Various Grades in Convenient Dropper Bottle Size ONLY 80p each

PUMA RACING (Models) LTD.  
THE BARN . MOAT HOUSE WORKS . KINGS COUGHTON . ALCESTER . WARKS. TEL: 0789 765496



## NORTHERN MODEL CENTRE DONCASTER

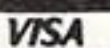

**NEW Tamiya Coloured Tyres, Yellow, Red, White**

Mail Order a pleasure



**KITS**  
Large Range of Tamiya, Kyosho, Schumacher and PB Kits. All Tamiya Spares stocked. Also Kyosho, PB and Schumacher spares

NMC 7.2v Packs £10.95  
Tamiya Racing Packs £18.50

**RADIOS**  
Acoms, Futaba and large range of spares. **GOODIES!!**  
PARMA Pactra and TAMIYA lexan paint. Large stocks of bodies and stickers. SRM, TMS and PARMA accessories including TMS steel one way drive shafts and SRM one way hubs to fit Mini Mustang

**BATTERIES**  
Large range of Sanyo's SC & SCRs. Tamiya, Parma, Overlanders, Schumachers.  
**CHARGERS**  
Thunder Tiger quick chargers £13.00. MFA charging monitor, Acoms quick charger £22.00. Schumacher PC1 & PC3 and Laser Thermal Chargers



**MOTORS**  
Modified & Standard Schumacher, Parma, Demon, MG, Kyosho, Tamiya, Yokomo, Scorchers, Screammers

**GIVE US A RING**  
(0302) 329636

27 HALLGATE, DONCASTER, S. YORKS

# Radio Race Car Back Issues

Associated RC 121	RRC 10/15
Associated RC 500	RRC 17
Associated RC 10	RRC 26
Associated 12L	RRC 44
ATC 500R	RRC 14
AYK Sidewinder	RRC 24
Bandai Mad Wolf	RRC 41
Bolink Bandito	RRC 27
Bolink Bigger Digger	RRC 11
Bolink Renegade	RRC 24
BS Special	RRC 16
Columbia I.S.4	RRC 10
Delta Eagle	RRC 21/19
Delta Phaser	RRC 24
DWA Commando	RRC 40
Hirobo Alien	RRC 40
Hirobo Bearcat	RRC 37
Hirobo Rock'n'City	RRC 19/RCMW 2
Hirobo Zerda	RRC 27
Hobby World Turbo	RRC 18
1/10 Suspension	RRC 37
Incident	RRC 39
Jac Rabbit	RRC 44
Kyosho Cosmo	RRC 29
Kyosho Gallup	RRC 17
Kyosho Indiana 4x4	RRC 22
Kyosho Integra	RRC 24
Kyosho Progress	RRC 39
Kyosho Rocky 4WD	RRC 12
Kyosho Scorpion	RRC 21
Kyosho Tomahawk	RRC 17
Kyosho Toyota Hilur	RRC 45
Kyosho Ultima	RRC 18
Mantua Manta	RRC 16
1/8th suspension	RRC 28
Mantua Nevada de luxe	RRC 39
Mantua T-U-R-B-O	RRC 26
Mardave Meteor	RRC 29
Mardave Mini Stocker	RRC 24
Marui Big Bear	RRC 41
Marui Hunter	RRC 23
Marui Ninja	RRC 11
Marui Super Wheelie	RRC 35
Micro Cross	RRC 18
MRP Pro 110	RRC 28
Muggen Bulldog	RRC 46
Nichimo Luminous	RRC 28
Nova X4	RRC 28
Parma Bobcat	RRC 15
Parma Cheetah (1/8th Scale)	RRC 11
Parma Panther	RRC 15
PB Alpha Developments	RRC 12
PB Mini Mustang	RRC 38
PB Nova	RRC 21/23
Playtron Doberman	RRC 29
Powermax Kangaroo	RRC 44
Puma International	RRC 24
Robbe Testarossa	RRC 46
R.P.S. Yokomo 1/10 S.E.	RRC 34
Schumacher 'C' car	RRC 16
Schumacher Cat	34/35/36
Schumacher The Big Cat	RRC 46
Sicom Magnum	RRC 38
Sicom Magnum Propulsion	RRC 45
Tamiya Audi Quattro	RCMW 1
Tamiya Blackfoot	RRC 38
Tamiya Boomerang	RRC 35
Tamiya Big Wig	RRC 36
Tamiya F.A.V.	RRC 26
Tamiya Frog	RRC 20
Tamiya Grasshopper	RRC 22
Tamiya Hornet	RRC 24
Tamiya Hotshot	RRC 28
Tamiya Hotshot II	RRC 45
Tamiya Monster Beetle	RRC 42
Tamiya Pajero	RRC 23
Tamiya Porsche 959	RRC 40
Tamiya Striker	RRC 43
Tamiya Subaru Brat	RRC 18
Tamiya Superchamp	RRC 14
Tamiya Supershot	RRC 34
Tamiya Tamtech Cars	RRC 42
Tamiya Willy's Wheeler	RRC 20
Texas Wild Baja	RRC 10
Thunder Tiger Silver Fox	RRC 24
Yankee Electra	RRC 42
Yokomo Dogfighter	RRC 23
Yu Can	RRC 14
Yumbo 1/10th	RCMW 4

A limited number of back issues of your favourite magazine are available from the publishers.

Price: Issues 3 - 9 60p each inc. P&P  
 Issue 10 onwards £1.00 each inc. P&P  
 Issue 30 onwards £1.15 inc. P&P

Not only are they informative and enjoyable reading but they make a fascinating account of the recent activity and development of the sport. Send your cheque/P.O. (made payable to 'Traplet Publications') to:-

Radio Race Car, Masefield House, Wells Road, Malvern, Worcestershire, WR14 4PA, England. We regret that Issues 1, 2, 8, 12 and 31 are no longer available.

Name .....

Address .....

Issues required .....

I wish to pay by Cheque/P.O./Access/Visa Credit Card

No ..... 

Expiry Date .....

Signature .....

## Reserve future copies of

# Radio Race Car

# NOW!

Take this form to your local newsagent or Model Shop. Please reserve me ..... copy(s) of Radio Race Car each issue.

Name .....

Address .....

Distributed to the Newsagent by:  
**Magnum Distribution Ltd., Cloister Court, 22-26 Farringdon Lane, London EC1R 3AV. Tel: 01-253 3135**

Distributed to the Model Trade by:  
**Traplet Publications Ltd., Masefield House, Wells Road, Malvern, Worcs. WR14 4PA. Phone 06845 60561/2.**

# Radio Race Car SEW-ON PATCH ONLY 50p

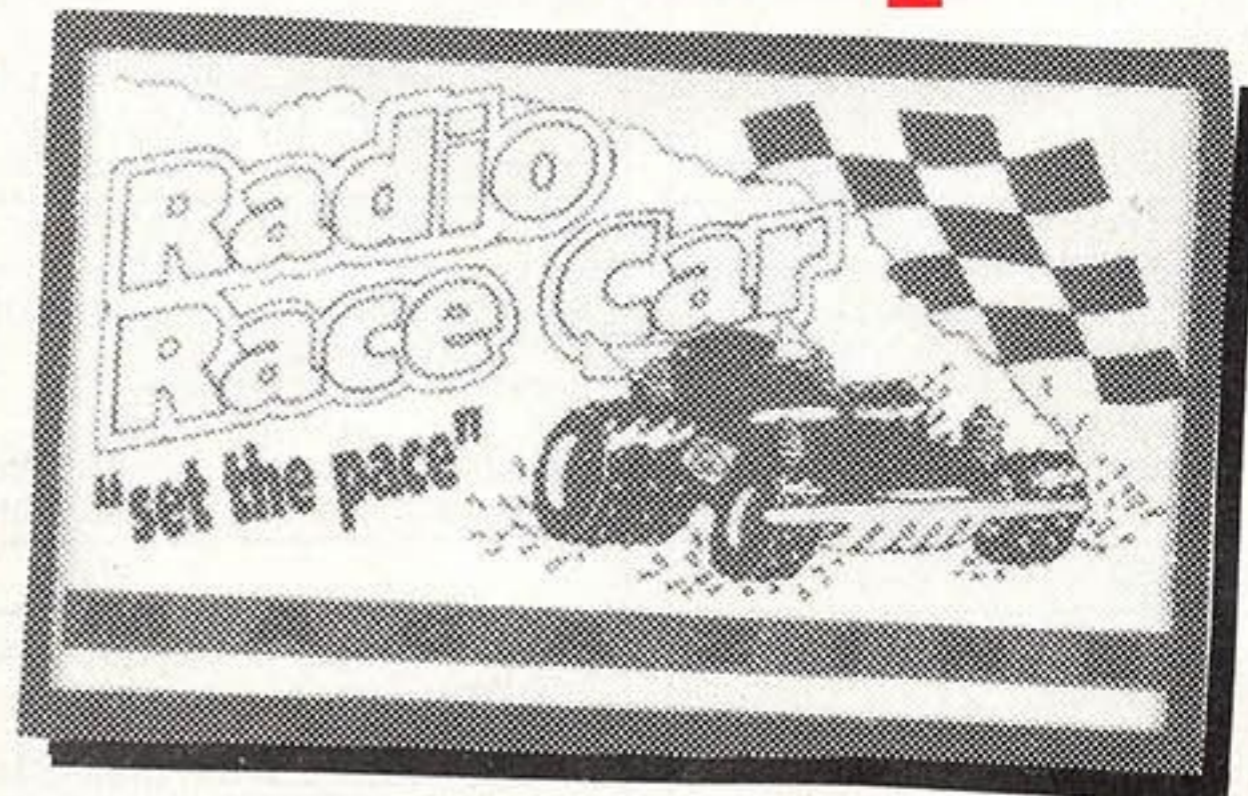

ENCLOSE SAE AND SEND TO:

Sew-on Patch Offer, Traplet Publications Ltd., Masefield House, Wells Road, Malvern, Worcs. WR14 4PA England

# Shopper's Directory

<b>AVON</b> <b>Avon Models</b> Tel. 0934 28305 39 Locking Road, Weston Super Mare Open Sunday. Closed Mon & Tues. All Credit Cards. Part Exchange. <i>Mail Order</i>	<b>ESSEX</b> <b>L &amp; M Euro Models</b> Tel. 0277 626628 7 Pauline Gardens, Billericay, Essex CM12 0LB Open Mon-Sat 9am-6pm Access <i>Mail Order</i> Visa	<b>Racestore</b> Tel. 0727 64532 130 London Road, St Albans. Mon-Sat 9.30am-5.30pm Closed all day Tuesday Access <i>Mail Order</i> Visa	<b>Windmill Models</b> Tel. 0282 52577 150/152 James Street, Burnley, BB11 1NR. Mon-Sat 9.30am-5.30pm Closed Tues. Manufacturers of Lectricar Products Access <i>Mail Order</i>
<b>BEDFORDSHIRE</b> <b>Maple Models</b> Tel. 0582 28435 62 Fountains Road, Luton, Beds. LU3 1LY Mon-Sat 9am-5.30pm Late night Wed. till 7.30pm Access <i>Mail Order</i> Visa	<b>Model Land</b> Tel. 01 500 3891 219 New North Road, Hainault. Mon, Tues, Wed, Sat, 9am-6pm Thurs 9am-1pm. Late night Fri. 9am-7.30pm 24 Hour Mail Order	<b>The Model Centre Too</b> Tel. 0442 21-21A High Street, 42926 Hemel Hempstead, Herts. Open 9.30am-5.30pm Mon-Sat Access <i>Mail Order</i> Visa	<b>LEICESTERSHIRE</b> <b>Leicester Model Centre</b> Tel. 0533 Stafford Street Corner, 666363 Melton Road, Leicester.
<b>BERKSHIRE</b> <b>W. J. Daniel &amp; Co Ltd</b> Tel. 0753 120 Peascod Street 862106 Windsor. Mon-Sat 9am-5.30pm Tamiya Specialists Access Visa	<b>Radio Active Models</b> Tel. 04022 50272 54 St Mary's Lane, Upminster, Essex RM14 2QT. Open Mon-Sat 9am-6pm 9.00am-7pm Friday Access <i>Mail Order</i> Visa	<b>KENT</b> <b>Ashford Models</b> Tel. 0233 39184 68 Kent Avenue, Ashford. Mon, Tues 9.45am-6pm, Wed-1pm Thurs-8pm, Fri 5pm, Sat 5.30pm Access <i>Mail Order</i> Visa	<b>LONDON</b> <b>C. &amp; E. Fuller Ltd</b> Tel. 01 778 6733 188 High Street, Penge, London SE20 7QB Mon-Sat 9.30am-6.00pm Wed 9.30am-1.00pm <i>Mail Order</i>
<b>Reading Model Supplies</b> Tel. 0734 5 Chatham Street, 51558 Reading. Open 9.00am-5.30pm Six days a week Access <i>Mail Order</i> Visa	<b>Radio Active Models</b> Tel 0245 442164 100 Main Road, Broomfield, Chelmsford, Essex. Open 9am-6pm Mon, Tues, Wed, Thurs, Sat. Late night Fri 9am-7pm Now open 6 days a week <i>Mail Order</i>	<b>Ballards</b> Tel 0892-31803 54 Grosvenor Road, Tunbridge Wells, Kent TN1 2AS Open 9am-5.30pm Mon-Sat 9.30am-12.30pm Wed Access <i>Mail Order</i> Visa	<b>Michaels Models</b> Tel. 01 445 6531 646-648 High Road, North Finchley, London N12 0NL Mon-Sat 9.30am-5.30pm Access <i>Mail Order</i> Visa
<b>Windsor Models</b> Tel. 0753 856321 45 Albany Road, Windsor, Berks. Open 9am-6pm Mon-Sat Closed 1pm Wed Access <i>Mail Order</i> Visa	<b>Radio Racer Models</b> Tel. 0702 614499 445 C/D Southchurch Road, 612291 Southend-on-Sea, Essex Mon-Fri 1.30-5.30pm and 7-9pm Closed Wed pm. Sat 10am-6pm Access <i>Mail Order</i> Visa	<b>Canterbury Model Shop</b> Tel. 0227 4 Butchery Lane, 453896 Canterbury, Open 9.00am-5.30pm Mon-Sat Access <i>Mail Order</i> Visa	<b>H. J. Nicholls &amp; Son</b> Tel 01 607 308 Holloway Road, 2961 or 4272 London N7 6NP Open 9am-5.30pm Mon-Sat Access <i>Mail Order</i> Visa
<b>CAMBRIDGESHIRE</b> <b>Orton Models</b> Tel. 0733 68200 36 Herewood Centre, Peterborough, Cambs. Tues, Wed, Fri. 9.30am-5.00pm Thurs 11.30am- 6pm. Sat. 9am-5.30pm Access <i>Mail Order</i> Visa	<b>Wheelspin Models</b> Tel. 0702 331443 145 Hoblethick Lane, Westcliff-on-Sea, Essex SS0 0RL 9.30am-5.30pm Mon, Tues, Wed, Thurs, Sat. 9.30am-6.30pm Fri. Access <i>Mail Order</i>	<b>Modelcrafts</b> Tel. 0474 874085 27 Upper Street North, New Ash Green. Mon-Sat 9am-5.30pm Friday 9am-8pm Access <i>Mail Order</i> Visa	<b>Model Stop</b> Tel 01 524 9384 6 Kings Road, Chingford, London E4 7EY. Mon-Thurs 9am-5.30pm. Fri. 9am- 8pm. Sat 9am-6pm. Sun 10am-1pm Access <i>Mail Order</i> Visa
<b>CORNWALL</b> <b>Splinters</b> 0726-64241 46 Fore Street, St. Austell, Cornwall, PL25 5PY Evenings by Appointment Mon-Sat 9.30am-5.00pm Access <i>Mail Order</i> Visa	<b>HAMPSHIRE</b> <b>Fratton Bargain Shop</b> Tel. 0705 171-173 Fratton Road 827117 or Fratton, Portsmouth. 750774 9am-6pm 6 days a week <i>Mail Order</i> All Credit Cards Accepted	<b>Swanscombe Models</b> Tel. 0322 2 The Parade, 843152 Swanscombe, DA10 0AJ Mon, Tue, Fri, Sat 9.30am-6pm Wed 9.30am-1pm. Thurs 9.30-8pm Access <i>Mail Order</i> Visa	<b>Pit Stop Models</b> Tel. 01 474 6171 344 Barking Road, Plaistow, London E13 Open 9.30am-6.00pm Mon-Sat Wed. early closing Access <i>Mail Order</i> Visa
<b>CUMBRIA</b> <b>Classic Models</b> Tel 0228 38250 6 Botchergate, Carlisle, CA1 1SH Mon-Sat 9.00am-5.30pm Access <i>Mail Order</i> Leisurecard Visa	<b>Ray Brown Models</b> Tel. 0705 825049 10 Kingston Road, Portsmouth, PO1 5RZ 9.30am-5.30pm Closed all day Wednesday Access <i>Mail Order</i> Visa	<b>LANCASHIRE</b> <b>Bury Model Shop</b> Tel. 061 764 3036 23 Bolton Street, Bury, Lancs. BL9 0EY Mon-Sat 9am-6pm Closed all day Tuesday Access <i>Mail Order</i> Visa	<b>MERSEYSIDE</b> <b>Formby Model &amp; Hobby Scene</b> Tel 77-79 Gores Lane, 07048-70432 Formby, Merseyside Mon-Sat 9.30am-5.30pm Closed all day Wednesday Access <i>Mail Order</i> Visa
<b>DERBYSHIRE</b> <b>Newbold Service Station (Esso)</b> Newbold Road, Tel. 0246 205384 Chesterfield. Mon-Fri 10am-6pm Sat. 10am-2pm Access <i>Tamiya Stockists</i> Visa	<b>Solent Models Ltd</b> Tel. 0703 331859 61-63 Bernard Street, Southampton, SO1 1BA. Mon-Sat 9.30am-5.30pm Accepts all Credit Cards <i>Mail Order</i> Expert advice electric & i.c., spares	<b>Craft &amp; Hobbies</b> Tel. 0254 55871 107-109 Johnston Street, Blackburn BB2 1HY Open Monday-Saturday	<b>MIDDLESEX</b> <b>Brentford R/C Centre</b> Tel. 01 560 5 Albany Parade, High St., 6856 Brentford, Middlesex. Mon-Sat 9.30am-6.00pm Late Night Fri. 8.00pm Access <i>Mail Order</i> Visa
<b>DEVON</b> <b>Exeter Model Centre</b> Tel. 0392 38 Sidwell Street, 35118 Exeter, Devon Mon-Sat 9.00am-5.30pm Access <i>Mail Order</i> Visa	<b>S.R.M. Racing</b> Tel 0329 234262 140 West Street, Fareham, Hants. Open 9am-5.30pm Mon-Sat Access <i>Mail Order</i> Visa The Racers Source	<b>Pendle Models</b> Tel 0282 64818 319 Leeds Road, Nelson, Anytime Lancs BB9 8RW Mon-Sat 10am-6pm. Late night Thursday 8pm Access <i>Mail Order</i> Visa	<b>Phil Greeno Models Ltd.</b> Tel 01 866 3 Village Way East, 7770 Rayner's Lane, Harrow, Mdx. HA2 7LX Open 9.30am-6pm Mon-Fri Sat 9.30-5pm. Wed. 9.30am-1pm Access <i>Mail Order</i> Visa
<b>Mansels</b> Tel. 0803 521767 Palace Avenue, Paignton, Devon PQ3 3EN. Open 9.00am-6.00pm Wed 9am-1pm Access <i>Mail Order</i> Visa	<b>HERTFORDSHIRE</b> <b>Model Images</b> Tel. 0462 684859 56 Station Road, Letchworth, SG6 3BE. Mon-Sat 9am-5.30pm. Late night Fri 9am-7pm. Sun 9.30am-12.30pm All credit cards accepted	<b>The Islander RC Models</b> Tel. 0254 Burma Garage, 55316 Tontine Street, Blackburn, Lancs. Open Mon-Sat 9.30am-6.00pm Half Day Thurs 1pm Access <i>Mail Order</i> Visa	<b>Red Baron Models Ltd</b> Tel 01 804 497 Hertford Road .7452 Enfield, Middx. Open 9am-6pm Mon-Sat Friday 9am-7pm Access <i>Mail Order</i> Visa



<p><b>Seymour Models</b> Tel. 01 427 6296 150 College Road, Harrow Buggy &amp; Stock Car Specialists Mon-Sat 10am-6.30pm Wed. 10am-1.30pm Access Mail Order Visa</p>
<p>The Model Shop Tel. 01 863 9788 190-194 Station Road, Harrow, Middlesex. Open 9.30am-6pm Mon-Sat Wednesdays 9.30am-5pm Access Mail Order Visa</p>
<p><b>NORFOLK</b></p> <p><b>Barney's Model Shop</b> Tel. 0553 1st Floor, 764540 29 St James Street, King's Lynn, PE30 5DA. Tues-Sat 9.00am-5.30pm Access Mail Order Visa</p>
<p><b>Galaxy Models</b> Tel. 0603 419515 88 Catton Grove Road, Norwich NR3 3AA Open 9am-5.30pm 6 days a week Access Mail Order Visa</p>
<p><b>NORTHANTS</b></p> <p><b>Stagg Models</b> Tel 0604 35718 22 Bridge Street, Northampton, Open 9am-5.30pm Mon, Tue, Wed Sat. Half day Thurs. late night Fri 7pm Access Mail Order Visa</p>
<p><b>The Model Shop</b> Tel. 0604 31223 230 Wellingborough Road, Northampton NN1 4ES Mon-Sat 9.00am-5.30pm Thursday 9.00am-1.00pm Access Diners Mail Order Amex Visa</p>
<p><b>NOTTINGHAMSHIRE</b></p> <p><b>Leicester Model Centre</b> Tel. 0602 85 Mansfield Road, 412407 Nottingham. Open 9.00am-5.30pm Closed all day Thursday</p>
<p><b>Phil Booth Models</b> 0773 769323 54 Valley Drive, Newthorpe, Notts. 9.30am-5.30pm. Closed lunch 1-2 Closed Mon. Late Night Thurs 7.30 1/10th Buggy Specialists</p>
<p><b>Portprince Models &amp; Hobbies Ltd</b> 43-45 Castlegate, Tel. 0636 73116 Newark, Notts. Open 9.30am-5.30pm Mon-Fri 9.00am-5.00pm Saturday Access Mail Order Visa</p>
<p><b>SHROPSHIRE</b></p> <p><b>Radio Control Products</b> Tel. 07462 21 Whitburn Street, 2291 Bridgnorth, WV16 4DN. Mon-Sat 9.00am-6.00pm Access Mail Order Visa</p>
<p><b>Telford Models</b> Tel. 0952 44779 5 Bell Street, Wellington, Shropshire Mon-Sat 9.00am-6.00pm Access Mail Order Visa</p>
<p><b>SOMERSET</b></p> <p><b>Nic's Kits</b> Tel 0935 825222 3 North Street, Martock, Somerset, TA12 6DH. Open 9am-1pm Mon 9am-5.30pm Tues-Thurs 9am-7pm Fri 9am-5pm Sat Mail Order</p>

<p><b>STAFFORDSHIRE</b></p> <p><b>The Model Car Centre</b> Tel. 0782 202 Werrington Road, 281810 Bucknall, Stoke-on-Trent ST2 9AW Open Mon-Sat. 9.00am-5.00pm Access Mail Order Visa</p>
<p><b>SUFFOLK</b></p> <p><b>Model Junction</b> Tel 0284 3456 10 Whiting Street, Bury St Edmunds, Suffolk Open 9.00am-6.00pm Mon-Sat Access Mail Order Visa</p>
<p><b>SURREY</b></p> <p><b>Godalming Radio Control Models</b> 3 &amp; 3A Bridge Street Tel. 04868 21425 Godalming. Mon-Sat 10.30am- 5.30pm incl. lunchtime. Com- prehensive stocks of Tamiya kits &amp; spares Access Visa</p>
<p><b>Mick Charles Models</b> Tel (01942) 0012 33 Combe Rd., New Malden, Surrey Open Mon-Sat. 9.30am-5.30pm Closed All Day Wednesday Late Night Fri 9.30am-8.00pm Access Mail Order Visa</p>
<p><b>Tommy Harris Models Ltd.</b> Tel. 155 Stafford Road, 01 647 1428 Wallington, Surrey. Open Mon-Sat. 9.30am-6.00pm Late Night Fri. 7.30pm Access Mail Order Visa</p>
<p><b>SUSSEX</b></p> <p><b>Harry Brooks</b> Tel 0273 418225 13-15 Victoria Road, Portslade, Brighton, Sussex. Open 6 days a week 8.30am-5.45pm Access Mail Order Visa</p>
<p><b>Model Aerodrome</b> Tel. 0273 26790 37 West Street, Brighton, East Sussex BN1 2RE Open Mon-Fri 9am-5pm Access Visa Amex Mail Order</p>
<p><b>TYNE &amp; WEAR</b></p> <p><b>The Model Shop</b> Tel. 091 2322016 18 Blenheim Street, Newcastle-upon-Tyne. Open 9.00am-5.30pm Mon-Sat Closed all day Wednesday Access Mail Order Visa</p>
<p><b>WEST MIDLANDS</b></p> <p><b>Apple Models</b> Tel. 021 422 1000 500 Hagley Road, Oldbury, Warley, W. Midlands B68 0NR. Open 9.30am-6.15pm Mon-Fri Sat 9.30am-5.30pm Access Mail Order Visa</p>
<p><b>Bob's Models Ltd</b> Tel. 021 742 3949 99 Hobs Moat Road, Solihull, West Midlands B92 8JL. Mon, Tues, Sat 9.30am-5.30pm. Thurs, Fri 9.30am -6pm. Closed all day Wednesday Access Mail Order Visa</p>
<p><b>Jim Davis Models</b> Tel. 021-359-0828 Unit 4 The Parkway, Heneage Street, Birmingham B7 4LY 9am-6pm six days a week All major credit cards accepted</p>
<p><b>Mike's Models</b> Tel. 021-360-7350 5 Brockwell Road, Kingstanding, Birmingham B44 9PE Open Mon-Sat 9.30am-6pm Mail Order</p>

<p><b>Penn Models</b> Tel 0902 334448 317 Penn Road, Wolverhampton, WV4 5QF Open Mon-Thurs 9.30am-6pm 9.30am-7pm Fri. 9am-6pm Sat Access Mail Order Visa</p>
<p><b>YORKSHIRE</b></p> <p><b>Airedale Models</b> Tel. 0535 665662 156 Station Bridge, Bradford Road, Keighley, West Yorks. Mon-Sat 9.30am-5.30pm Closed Tuesday Access Mail Order Visa</p>
<p><b>Flying Models</b> Tel 0532 646117 88 Crossgates Road, Leeds, Yorkshire, LS15 7NL Open 6am-6pm Mon-Sat 8am-1pm Sunday Access Mail Order Visa</p>
<p><b>Les Brown Models</b> Tel. 0924 441991 12A Bond Street, Birstall, Batley, West Yorkshire 9.30am-6.30pm Mon-Sat Access Mail Order Visa</p>
<p><b>Morley Models</b> Tel 0532 522693 10-12 Cheapside Morley, W. Yorks. 9.30am-5.45pm Mon, Wed, Thurs, Fri, Sat. Closed 12.30pm-1pm and all day Tues Access Mail Order Visa</p>
<p><b>Northern Model Centre</b> Tel. 0302 27 Hallgate, 329636 Doncaster DN1 3NL Open 9am-6pm. Late night Fri. 8pm Access Mail Order Visa</p>

<p><b>Otley Modelsport</b> Tel. 0943 466535 2 Cross Green, Otley, W. Yorks. LS2 1HD Open 9am-5.30pm Mon-Sat 9am-1pm Sun. Access Mail Order Visa</p>
<p><b>P &amp; S Hobbies &amp; Models</b> Tel 32 Castle Road, 0723 377020 Scarborough, N. Yorkshire. Open Mon-Sat 10am-5.30pm Mail Order</p>
<p><b>Three Towers Models</b> Tel 0422 58 Haley Hill, 44403 Halifax, W. Yorks. Open 9.45am- 5pm Mon, Tues, Thurs, Fri, Sat Closed 1-1.30pm and all day Wed. Access Mail Order Visa</p>
<p><b>SCOTLAND</b></p> <p><b>Wonderland Models</b> Tel 031 229 97 Lothian Road, 6428 Edinburgh, EH3 9AN Mon-Fri 9.30am-6.00pm Sat 9.00am-5.30pm Access Mail Order Visa</p>
<p><b>WALES</b></p> <p><b>Abergavenny Model Shop</b> Tel Above the Pet Shop, 0873 2566 Frogmore St/Brecon Rd., Abergavenny, Gwent NP7 5AL Tues-Sat 9am-5.30pm Closed all day Monday Mail Order</p>
<p><b>NEW ZEALAND</b></p> <p><b>Peter Pan Hobbies and Supplies</b> 55 St George St., Tel. 2787488 Papa Toetoe, Auckland. Mon-Sat 8am-5.30pm Late Night Friday Mail Order Service Bankcard Visa</p>

## ANNUAL SUBSCRIPTION

Please send me Radio Race Car Magazine for one year (12 copies). I enclose a cheque/postal order for £18.00 UK., £22.00 (Sterling) Europe, £31.00 (Sterling) Worldwide (Air-mail)\*. \* Delete not applicable.

To all our American readers, why not take advantage of a special 12 months subscription — only \$35.00 Payable in US Dollars to Traplet Distribution USA, 1635 Wade Drive, Paso Robles CA93446 USA

Subscription commencing issue .....

Signed .....

Name ..... Address .....

..... Postcode .....

Access or Visa Number .....

Expiry Date .....

PLEASE PRINT CLEARLY IN BLOCK CAPITALS

Return to:— Radio Race Car, Masefield House,  
Wells Road, Malvern Wells,  
Worcestershire WR14 4PA, ENGLAND.

If you do not want to spoil your mag just photocopy this  
Subscription Form or enclose all details in a letter.)

# CLASSIFIED ADVERTISEMENTS

## FOR SALE

Two World Championship Video showing all two and four wheel drive A finals and qualifying heats. Interviews with top drivers and manufacturers are also featured in this top quality VHS Video. Price: £25.00.

All enquiries to:  
Mr. M. Stevenson, 102 Martins Lane, Hardingstone,  
Northampton NN4 0DJ Tel: 0604 768634

**BOOMERANG** fully ballraced, 480G, 540 motors, Supershot suspension, 7.2v battery, quick charger, Challenger 250 radio gear, V.G.C. £150 o.n.o. Ring (08045) 4649.

**TAMIYA** Sandscorcher, 7.2v battery, slow and quick charger, two bodies, Beatties bag, extras, V.G.-condition. £115 o.n.o. Tel 01-998-6125. Demonstration welcome.

**LAP** counter computer program for Commodore 64 or VIC/+ features include random start, instant readout timed laps, printer facility. State computer type cartridge or disc. Send £4.99 inclusive to 10 Copperleaf Close, Moulton, Northampton. Tel: 494553.

**TAMIYA** Fox, Spirit 600 motor, Acoms control, three racing packs, fast/slow charger, new chassis, spare wheels. Only £120. Tel: 04946 3118.

**OPTIMA** everything for sale, 2 motors (Demon), 2 x 7.2 Sanyos, Laser Bug S/cont new Futaba radio, M.F.A F & S charger, 12v bat, 3 bodies, load of spares complete outfit, used only on carpet for £199 (no radio) £150. Tel: 0859 823231.

**TAMIYA** Falcon with 7.2 battery and Tamiya RS540SD black motor sprint £51. Tel: Northwich 0606 76220.

**RC10** fully ballraced. Fox wheels with spare tyres two bodies, all good condition. Cost £180 new accept £75. Tel: 0326 572878.

**RACING NUMBERS — BE SEEN — BE COUNTED** Self adhesive vinyl racing numbers. More resistant to weathering. Can be washed clean when muddy. Sheet VN4 contains 1 of each no. from 1-12. Min. order 20 sheets — 45p per sheet inc. VAT & post. Cheque with order. **CIRCUIT PROMOTIONS** 1 Russell Street, Gloucester.

**NEW** Attach B.E.C. £40. Schumacher Charger £25, Demon 19T Quad £17, Demon SCR Reds £15, Tamiya Battery £12. 0908 665497.

**BARGAIN** PB Mustang Super Com, spare engine one and two speed gear box, four bodies, radio control electric starter. Must sell fast £150 o.n.o. Welwyn Garden City (0707) 334933.

**OPTIMA** Futaba radio, 3 servos, Futaba 118 Electric speed controller, 3 batteries, 2 sets of tyres, 3 bodies, Technigold, 240SB, K-stock, fast charger. Excellent condition £210 o.n.o. Simon 01-841-1215 weekends.

**SOUTH WALES DISTRIBUTOR** for Sanyo Nicad Batteries Competitive prices. Trade enquiries welcome. All sizes in stock. Tel 0873 2566

**FOX** with Acoms radio gear fully modified to racing standards complete with electronic charger/discharger, Sanwa Yellow cells, extensive spares, tyres and motor etc £135.00. Tel: 0292 311390.

**BOOMERANG** Acoms radio, charger, 7.2v battery, ballraced wheels £105, Hotshot, Acoms radio, charger, 7.2v battery, ballraced wheels £115 o.n.o. Tel: 023 371 2679 evenings.

**Only 25p PER Inc. VAT WORD**  
Radio Race Car's Classified Adverts give you the best value for money when you wish to sell any radio control equipment, or when you are looking for something special, why not try a 'Wanted' ad?  
Not only is it good value, it's fast!  
We will print any classified advert reaching us up until three weeks before the cover publication date.

**KYOSHO** Rocky with new Tamiya racing speed controller, partly ballraced + fast battery charger as new. Excellent condition. Bargain £75 o.n.o. Tel: 0827 830302.

**SERPENT** Cobra, latest Nova Rossi, XR 3, Cobra bodies, starter, fuel, spares, chargers, Futaba, 2 LGX radio, nicads, ready to race, cost £700+ sell £350. Maidenhead 32527.

## Private Advertisements

25p per word (inc. VAT). Minimum 20 words  
**Trade Advertisements Semi Display**  
£5.00 per column centimetre (inc. VAT).  
(x 57mm) Max. 7cms.

All classified advertisements must be prepaid

### RACING NUMBERS

Sheet RN1 contains 3 each of 1-4  
Sheet RN2 contains 3 each of 5-8  
Sheet RN3 contains 3 each of 9-12  
(i.e. 12 numbers per sheet) 25p per sheet inc. VAT & post. Minimum order 30 sheets.  
Cheque with order made payable to:  
**CIRCUIT PROMOTIONS, 1 Russell Street Gloucester**

**BOOMERANG** Sanwa radio Kyosho motor Sanyo nicads and slow charger new parts and some spares. Tel: Nick on (0895) 441050.

**OPTIMA** hardened chain, P.B. shocks fully ballraced, Hotshot wheels, Cat tyres, lots of spares. £80 o.n.o. Phone Newbury (0635) 68059.

**RC10** fully ballraced, Demon motor, Pro-line tyres, steering beef-up kit, rear anti-roll bar, Futaba FP-MC106B speed controller, Futaba radio FP2NFR, 3 drive nicads, model flight accessories charger 202, radio nicads + 2 chargers £350 o.n.o. Battersea 01-228-2251.

**CAT** 2 months old, Micro Rx, 132 servo, matched packs controller, Laser charger, spares £235. Also Supershot, radio gear, electronic controller, very modified, chargers, £115. 01-390-3487 after 5pm.

**SAMURAI** 4wd fully ballraced, good condition £80 o.n.o. Tel: 0276 73395 or 73397.

# Only 25p PER Inc. VAT WORD

Radio Race Car's Classified Adverts give you the best value for money when you wish to sell any radio control equipment, or when you are looking for something special, why not try a 'Wanted' ad?

Not only is it good value, it's fast!

We will print any classified advert reaching us up until three weeks before the cover publication date.

## ADVERTISERS INDEX

A1 Batteries .....	64	Northern Model Centre .....	78
Aero Nautical Models .....	59	One-o-One Models .....	17
Associated .....	18	Otley Modelsport .....	76
Avon & Taunton Models .....	64	PB Racing .....	4
BRCA .....	8	Peelers .....	57
Brimod .....	40	P & S Models & Hobbies .....	77
Central Models .....	66	Puma Racing Products .....	78
Cheltenham Model Centre .....	73	Radio Active (Chelmsford) .....	77
Colchester Model Cars .....	77	Radio Active (Upminster) .....	41
Futaba .....	83	Rails Racing Products .....	45
Galaxy Models .....	73	RC Products .....	44
GK Models .....	14, 15	R/C Video World .....	65
Howes Models .....	26, 27	RRC Back Issues .....	79
Infinite Trading Co .....	12	RRC Binders .....	77
Intronics .....	64	RRC Subscription Coupon .....	79
Jim Davis Models .....	19, 41	Riko .....	84
J. & P. Turner .....	44	Sarik Vac Form .....	56
J. W. Bagnall .....	67	Schumacher .....	25
K & B Models .....	24	Shrewsbury Model Centre .....	73
Kyosho .....	2	SLEC .....	60
Lesro .....	76	SRM .....	6, 7, 64
Macartney's Models .....	77	Stockton Modeller .....	13
Malvern Models .....	33	Tamiya .....	65
Mansels Models .....	9	Tamiya Championships .....	78
Metrobridge .....	40	Ted Longshaw .....	58
MG Model Products .....	67	The Model Car Centre .....	16, 17
Michaels Models .....	40	TMS .....	11
MMD .....	40	Trinity .....	42, 43
Model Craft .....	45	Tru-Tyres .....	41
Morley Models .....	5	Wasp Products .....	67
MRM Plastics .....	56	Windsor Model Shop .....	56
Nodis Racing Developments .....	45	Wonderland Models .....	44

Send your advertisements to **Radio Race Car Magazine**, Masefield House, Wells Road, Malvern, Worcestershire WR14 4PA

We will print your prepaid classified advertisement in the next available issue of *Radio Race Car*. Classified adverts received after copy date may be held over for the following issue. We advise you to type or print clearly (capital letters preferred) the text of your advert on a separate sheet of paper and clearly indicate whether the goods referred to are 'wanted' or 'for sale'. No responsibility will be accepted for misprints.

**Trade Description Act.** Attention should be paid to the requirements of the Act when giving detailed descriptions of all goods offered for sale. **The Business Advertisements (Disclosures) Order 1977** requires that persons attempting to sell goods in the course of business must make that fact clear. Consumers should know whether an advert relates to a sale by a trader or private seller.

# Futaba THE LOGICAL CHOICE

As different models require varying numbers of primary and ancillary controls, Futaba produce a range of systems for every modelling need. So whether your choice is Boats, Cars, Aircraft or Helicopters, choose the best in radio . . . . . FUTABA

## ATTACK

- 2 CHANNEL
- SERVO REVERSERS
- BEC RECEIVER  
+ BATTERY BOX

CARS ● BOATS ● GLIDERS  
● ELECTRIC AIRCRAFT ●

- 2 x S128 SERVOS
- TWIN POSITION  
THROTTLE NEUTRAL
- CARRY HANDLE

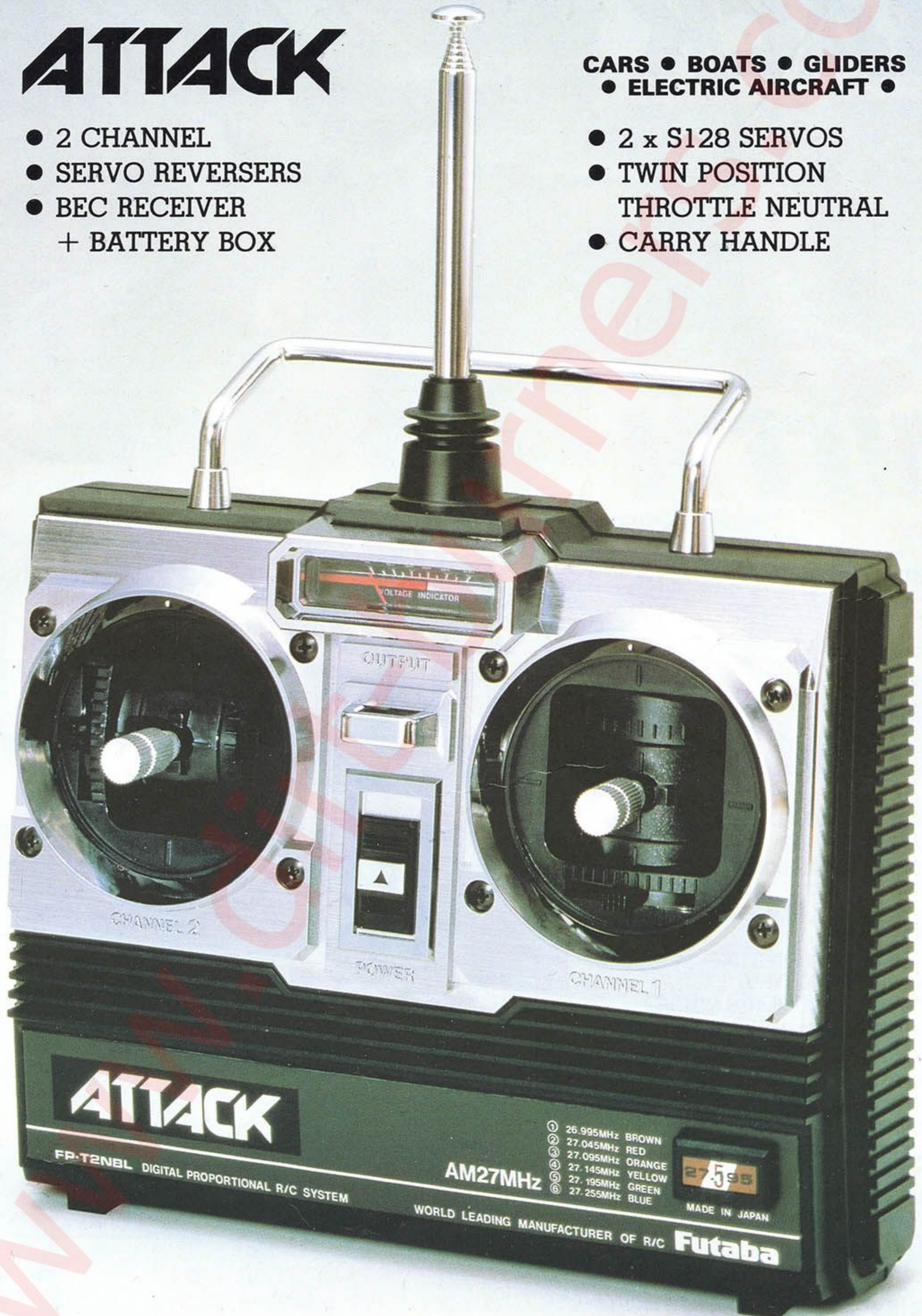

# GET YOUR OWN

# BACK



# WITH

# The Boomerang

R/C HIGH PERFORMANCE 4WD OFF ROAD RACER

- ★ READY TO ASSEMBLE R/C MODEL KIT
- ★ SHAFT DRIVEN 4WD
- ★ FRONT AND REAR DOUBLE WISHBONE SUSPENSION
- ★ ADJUSTABLE OIL DAMPERS FRONT AND REAR
- ★ LOW PROFILE RUBBER LIKE SEMI-PNEUMATIC TYRES
- ★ WITH POWERFUL RS-540S MOTOR
- ★ BATHTUB TYPE A.B.S. RESIN FRAME
- ★ POLYCARBONATE BODY AND WING
- ★ REQUIRES 2 CHAN. R/C EQUIPMENT
- ★ ACOMS RECEIVER BATTERY ELIMINATOR INCLUDED IN KIT
- ★ ACCEPTS 7.2V RACING PACK, REGULAR 7.2V OR 6V BATTERY.

FOR MAXIMUM PERFORMANCE USE ONLY TAMIYA Ni-Cads

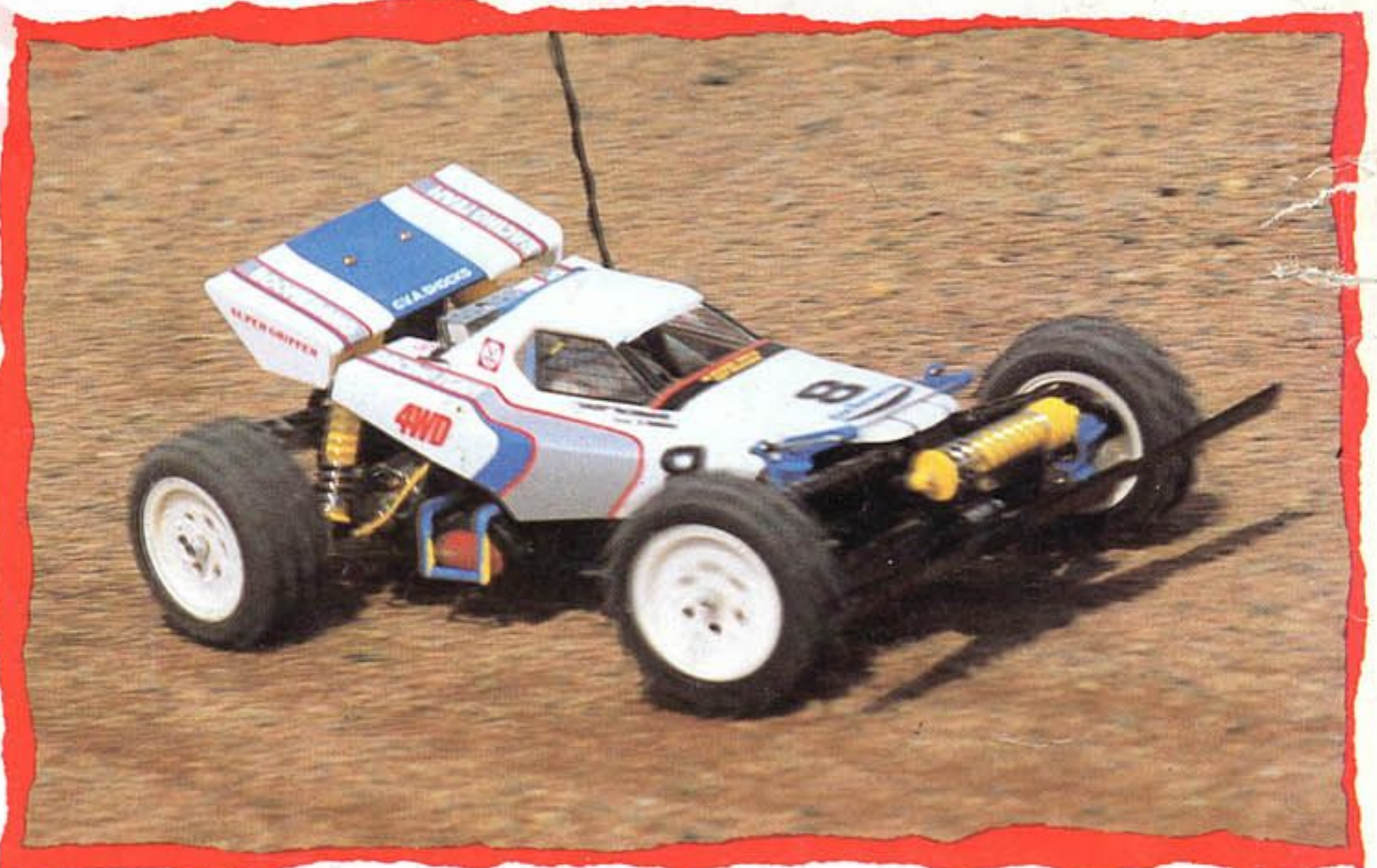

**RIKO**

**RICHARD KOHNSTAM LIMITED**

13-15a High Street, Hemel Hempstead, Herts.

